

1571

1591

INSTRUCTION MANUAL

1593

This instruction manual applies to machines
from the serial number # **7 274 018** onwards.



This instruction manual applies to all models and subclasses listed in chapter 3 Technical Data.



The adjustment manual for the machine can be downloaded at no charge under **www.pfaff-industrial.de/de/service-support/downloads/technical**. As an alternative to the Internet download, the adjustment manual can also be ordered as a hard copy under order no. **296-12-19 443/002**.

Reprinting, reproduction and/or translation of PFAFF instruction manuals (including parts thereof) is only permitted with our prior agreement and citation of the source.

**PFAFF Industriesysteme
und Maschinen GmbH**

Hans-Geiger-Str. 12 - IG Nord
D-67661 Kaiserslautern

	Contents.....	Page
1	Safety	6
1.01	Directives	6
1.02	General safety instructions	6
1.03	Safety symbols	7
1.04	Special points of attention for the owner-operator	7
1.05	Operating personnel and technical staff	8
1.05.01	Operating personnel	8
1.05.02	Technical staff	8
1.06	Danger warnings.....	9
2	Proper Use.....	10
3	Technical Data.....	11
3.01	PFAFF 1571.....	11
3.02	PFAFF 1591.....	12
3.03	PFAFF 1593.....	13
4	Disposal of the Machine.....	14
4.01	Environmental protection	14
5	Transportation, Packaging and Storage.....	15
5.01	Transport to the customer's premises	15
5.02	Transport within the customer's premises	15
5.03	Disposal of the packaging materials	15
5.04	Storage	15
6	Work Symbols.....	16
7	Operating Controls	17
7.01	Main switch	17
7.02	Keys on the machine head	17
7.03	Bobbin thread monitoring using stitch counting	18
7.04	Pedal.....	18
7.05	Hand lever to raise the roller presser.....	19
7.06	Swivelling out the roller presser.....	19
7.07	Knee switch	20
7.08	Knee lever.....	20
7.09	Edge trimmer -725/04 for PFAFF 1571.....	21
7.10	Edge trimmer -725/04 for PFAFF 1591.....	22
7.11	Control panel	23
7.11.01	Funktionstasten	24
7.11.02	Symbols	27

Table of Contents

	Contents.....	Page
8	Set-up and Initial Start-up	28
8.01	Set-up	28
8.01.01	Setting the table height	28
8.01.02	Inserting the sewing machine into the stand.....	29
8.01.03	Assembling the anti-tipping device	30
8.02	Mounting the flange motor	30
8.02.01	Mounting the flange motor on the bearing plate	30
8.02.02	Mounting the flange motor on the machine	31
8.02.03	Mounting the machine cover.....	31
8.02.04	Connecting the plug-in connections and ground cable.....	32
8.02.05	Fitting the toothed belt / home position of the machine drive with the PFAFF 1571; 1591 and 1593 ...	33
8.02.06	Mounting the flange motor belt guard	36
8.02.07	Connecting the safety switch	36
8.02.08	Checking the start inhibitor function.....	37
8.03	Assembling the reel stand	37
8.04	Initial start-up	38
8.05	Switching the machine on / off.....	38
9	Set-up.....	39
9.01	Inserting the needle	39
9.02	Winding the bobbin thread, adjusting the thread tension.....	40
9.03	Removing / inserting the bobbin case.....	41
9.04	Inserting the bobbin case, adjusting the bobbin thread tension.....	41
9.05	Threading the needle thread / adjusting the needle thread tension.....	42
9.06	Selecting a program number	43
9.07	Setting stitch lengths.....	45
9.08	Entering start and end backtacks	46
9.09	Switching on / setting the bobbin thread monitoring using stitch counting	48
9.10	Entering / changing the code number.....	51
9.11	Inserting and removing the SD memory card	53
10	Sewing	54
10.01	Manual sewing.....	54
10.02	Sewing with fixed programs.....	56
10.03	Program interruption	58
10.04	Error messages	58
11	Input.....	59
11.01	Seam program input via the “Create/correct program” function	61
11.01.01	Examples of seam program input using the “Create/correct program” function	61
11.02	Seam program input via the “Teach-in” function	68
11.02.01	Example for seam program input via the “Teach-in” function	68
11.03	Managing seam programs	76
11.04	Parameter settings.....	78
11.04.01	Overview of parameter functions	78

	Contents.....	Page
11.04.02	Example of a parameter entry	79
11.04.03	Parameter list for control P430SD	81
11.05	Error messages and description	84
11.06	Sewing motor errors	86
11.07	Warning messages	86
12	Maintenance and Care.....	87
12.01	Maintenance intervals.....	87
12.02	Cleaning the machine	88
12.03	Oiling the hook.....	88
12.04	Checking the oil level of the hook and front parts.....	88
12.05	Lubricating the bevel gears.....	89
12.06	Topping up the thread lubrication oil reservoir	89
12.07	Lubricating the roller presser drive gear mechanism (only for a diameter of 25 mm and 35 mm).....	90
13	Table Top	91
13.01	Tilt base	91
13.02	Table top cutout	92
14	Wear and Tear Parts	93

1 Safety

1.01 Directives

The machine was built in compliance with the European regulations specified in the declaration of conformity and declaration of incorporation.

As a supplement to this instruction manual, please also observe the generally applicable, legal and other regulations and legislation – also in the country of use – and the valid environmental protection regulations! Always comply with the locally applicable regulations of the professional associations and other supervisory authorities!

1.02 General safety instructions

- The machine may only be operated after you have become acquainted with the associated instruction manual and only by operating personnel who have received appropriate training!
- Always read the safety instructions and the instruction manual of the motor manufacturer before starting up the machine!
- Always follow the hazard and safety instructions attached to the machine!
- The machine may only be operated for its intended purpose and only with the associated safety covers, while adhering to all the relevant safety requirements.
- The machine must always be disconnected from the power supply by pressing the main switch or pulling out the mains plug when sewing tools are replaced (such as the needle, sewing foot, needle plate and bobbin) and when threading, leaving the workstation, or performing maintenance!
- The daily maintenance work may only be carried out by suitably qualified personnel!
- Repairs and special maintenance work may only be carried out by technical staff or people with appropriate training!
- Work on electrical equipment may only be carried out by qualified technical staff!
- Work on parts and equipment under voltage is not permitted!
- Exceptions are regulated by the EN 50110 standards.
- Modifications and changes to the machine may only be made in compliance with all of the relevant safety requirements!
- Only the replacement parts approved by us for usage may be used for repairs! We warn you expressly that spare parts and accessories that are not supplied by us are also not tested and approved by us.
Fitting or using these products may therefore have negative effects on features which depend on the machine design. We are not liable for any damage caused by the use of non-Pfaff parts.

1.03 Safety symbols



Hazard point!
Special points of attention.



Risk of injury to operating personnel or technical staff!



Electric voltage!
Danger to operating personnel or technical staff



Danger of hands being crushed!
Danger to operating personnel or technical staff



Caution!

Do not operate without finger guard and safety covers!
Turn off the main switch before threading, changing the bobbin or needle, cleaning, etc.!

1.04 Special points of attention for the owner-operator

- This instruction manual is a part of the machine and must be made available to the operating personnel at all times. The instruction manual must have been read before the initial start-up.
- The operating personnel and technical staff must be instructed about the machine's safety covers and about safe working methods.
- The owner-operator may only operate the machine in a flawless condition.
- The owner-operator must ensure that no safety covers are removed or disabled.
- The owner-operator must ensure that only authorised persons work on the machine.

Additional information can be requested from the responsible sales centre.

1.05 Operating personnel and technical staff

1.05.01 Operating personnel

Operating personnel are persons responsible for equipping, operating and cleaning the machine and for fault clearance in the sewing area.

The operating personnel are obligated to comply with the following points:

- The safety instructions provided in the instruction manual must be followed for all work!
- Any work method jeopardising machine safety must be refrained from!
- Tight-fitting clothing must be worn. The wearing of jewellery such as chains and rings is prohibited!
- Care must be taken to ensure that no unauthorised persons are located in the machine's hazard zone!
- Any changes occurring on the machine which impair its safety must be reported to the owner-operator immediately!

1.05.02 Technical staff

Technical staff are persons with technical training in electricity/electronics and mechanics. They are responsible for lubricating, servicing, repairing and adjusting the machine.

The technical staff are obligated to comply with the following points:

- The safety instructions provided in the instruction manual must be followed for all work!
- Turn off the main switch and secure it against reactivation before starting any adjustment and repair work!
- Never work on live parts and equipment!
Exceptions are regulated by the EN 50110 standards.
- Reattach the safety covers following repair and maintenance work!

1.06 Danger warnings



A work area of 1 m must be kept free in front of and behind the machine to ensure unobstructed access at all times.



Do not reach into the needle range during the sewing operation!
Risk of injury from the needle!



Do not allow any objects to be placed on the table during the adjustment work!
The objects could become jammed or be slung away!
Risk of injury from parts flying around!

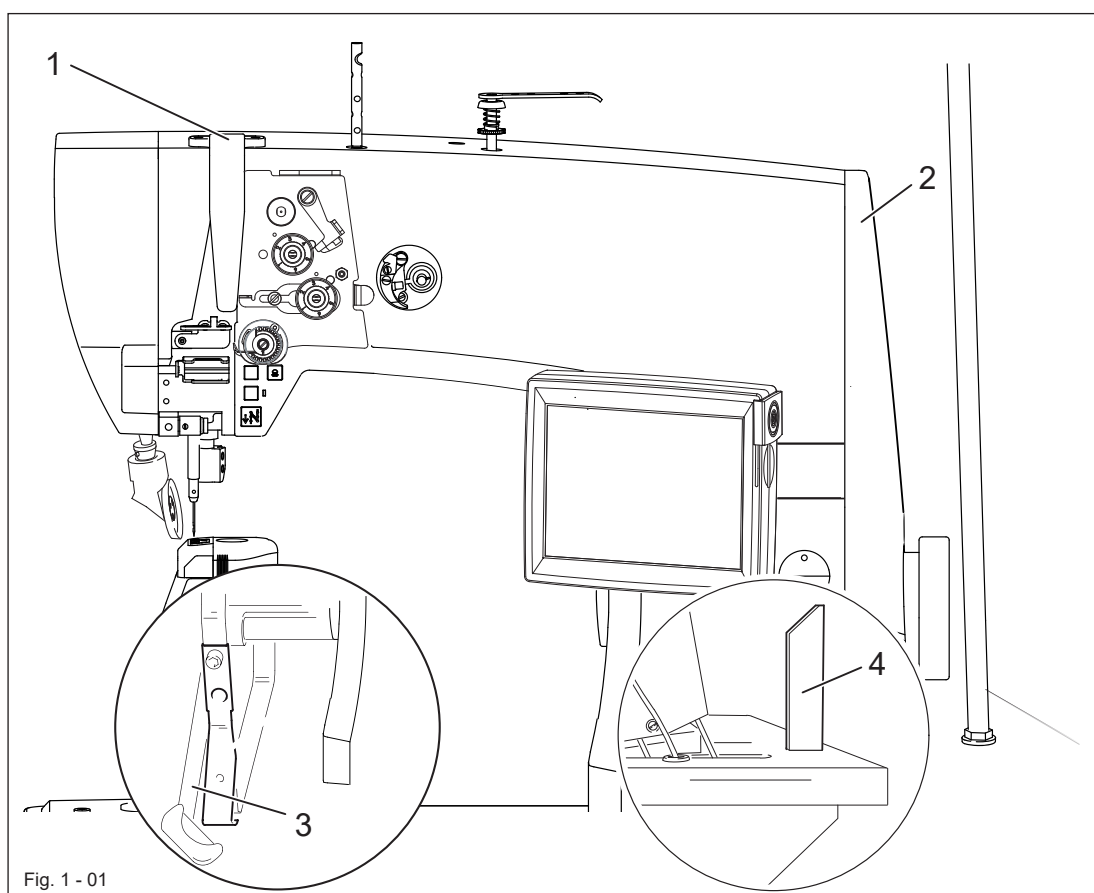

Fig. 1 - 01



Do not operate the machine without the take-up lever guard 1!
Risk of injury due to the motion of the take-up lever!



Do not operate the machine without the belt guard 2!
Risk of injury due to the rotating driving belt!



Do not operate the machine without the anti-tipping device 3!
Risk of injury by crushing between the sewing head and the table top!



Do not operate the machine without the support 4! Risk of damage due to the top-heavy sewing head!
Machine can tip over backwards when moving it!

2 Proper Use

The PFAFF 1571 is a single needle post-bed high-speed seamer (post is positioned to the left of the needle) with forwards- and backwards-moving feed wheel and roller presser plus feed-synchronised needle.

The PFAFF 1591 is a single needle post-bed high-speed seamer (post is positioned to the right of the needle) with forwards- and backwards-moving feed wheel and roller presser plus feed-synchronised needle.

The PFAFF 1593 is a single needle post-bed high-speed seamer (post is positioned to the right of the needle) with forwards- and backwards-moving feed wheel and roller presser.

The machines are used to create double lock stitch seams in the leather and upholstery industries.



Any usage not approved by the manufacturer is deemed misuse!

The manufacturer shall assume no liability for damage caused by misuse! Proper use also includes compliance with the operating, maintenance, adjustment and repair measures specified by the manufacturer!

3 Technical Data ▲

3.01 PFAFF 1571

Stitch type:	301 (lockstitch)
Needle system:	134
Model BN7:	for the machining of medium-weight materials
Model CN7:	for the machining of medium-heavy materials
Needle size in 1/100 mm:	
Model BN7:	80 - 100
Model CN7:	110 - 140
Stitch length max:	7.0 mm
Speed max.:	
Model BN7	3000 stitches/min ♦
Model CN7	2000 stitches/min ♦
Trimming margin (for -725/..)	1.2 - 1.5 mm
Cutting speed (for -725/..)	2800 cuts/min.
Clearance beneath the roller presser for dia. 25 mm; dia. 30 mm and dia. 35 mm:	12 mm
Passage width:	245 mm
Clearance height:	115 mm
Post height	180 mm
Bed plate dimensions:	518 x 177
Sewing head dimensions	
Length:	approx. 562 mm
Width:	approx. 250 mm
Height (above table):	approx. 505 mm
Motor data:	see motor specification plate
Noise data	
(Noise measurement in accordance with DIN 45 635-48-A-1, ISO 11204, ISO 3744, ISO 4871)	
Model B:	
Emissions sound pressure level in the workplace at n = 2800 min ⁻¹ :	L _{pA} = 80 dB(A) ■
Model C:	
Emissions sound pressure level in the workplace at n = 1600 min ⁻¹ :	L _{pA} = 74 dB(A) ■
Net weight of sewing head:	approx. 64 kg
Gross weight of sewing head:	approx. 74 kg

- ▲ Subject to alterations.
- ♦ Depending on the material, workstep and stitch length.
- K_{pA} = 2,5 dB

3.02 PFAFF 1591

Stitch type:	301 (lockstitch)
Needle system:.....	134
Model BN7:.....	for the machining of medium-weight materials
Model CN7:	for the machining of medium-heavy materials
Needle size in 1/100 mm:	
Model BN7:.....	80 - 100
Model CN7:	110 - 140
Stitch length max	7.0 mm
Speed max.:	
Model BN7	3000 stitches/min ♦
Model CN7	2000 stitches/min ♦
Trimming margin (for -725/..)	1.2 - 1.5 mm
Cutting speed (for -725/..)	2800 cuts/min.
Clearance beneath the roller presser for dia. 25 mm; dia. 30 mm and dia. 35 mm:	12 mm
Passage width:.....	245 mm
Clearance height:.....	115 mm
Post height	180 mm
Bed plate dimensions:.....	518 x 177
Sewing head dimensions	
Length:.....	approx. 562 mm
Width:.....	approx. 250 mm
Height (above table):	approx. 505 mm
Motor data:	see motor specification plate
Noise data	
(Noise measurement in accordance with DIN 45 635-48-A-1,ISO 11204, ISO 3744, ISO 4871)	
Model B:	
Emissions sound pressure level in the workplace at n = 2800 min ⁻¹ :.....	L _{pA} = 80 dB(A)■
Model C:	
Emissions sound pressure level in the workplace at n = 1600 min ⁻¹ :.....	L _{pA} = 74 dB(A)■
Net weight of sewing head:.....	approx. 64 kg
Gross weight of sewing head:	approx. 74 kg

- ▲ Subject to alterations.
- ♦ Depending on the material, workstep and stitch length.
- K_{pA} = 2,5 dB

3.03 PFAFF 1593

Stitch type: 301 (lockstitch)

Needle system: 134

Model BN7: for the machining of medium-weight materials

Needle size in 1/100 mm:

Model BN7: 80 -100

Stitch length max 7.0 mm

Speed max.:

Model BN7 3000 stitches/min ♦

Clearance beneath the roller presser for dia. 25 mm; dia. 30 mm and dia. 35 mm: 12 mm

Passage width: 245 mm

Clearance height: 115 mm

Post height 180 mm

Bed plate dimensions: 518 x 177

Sewing head dimensions

Length: approx. 562 mm

Width: approx. 250 mm

Height (above table): approx. 505 mm

Motor data: see motor specification plate

Noise data

(Noise measurement in accordance with DIN 45 635-48-A-1, ISO 11204, ISO 3744, ISO 4871)

Emissions sound pressure level in the workplace at $n = 2800 \text{ min}^{-1}$: $L_{pA} = 80 \text{ dB(A)} \blacksquare$)

Net weight of sewing head: approx. 64 kg

Gross weight of sewing head: approx. 74 kg

▲ Subject to alterations.

♦ Depending on the material, workstep and stitch length.

■ $K_{pA} = 2,5 \text{ dB}$

4 Disposal of the Machine

- The materials used for the machine include steel, aluminium, brass and various plastics. The electrical equipment consists of plastics and copper.
- The machine must be disposed of in accordance with the locally valid environmental protection regulations, with a specialised company being contracted if necessary.



Please ensure that parts coated with lubricants are disposed of separately in accordance with the locally valid environmental protection regulations!

4.01 Environmental protection

Careless disposal of the machine and its components may lead to environmental pollution.

- ➡ Dismantle assemblies into individual components. Dismantling must only be carried out by qualified personnel! Springs under tension must be relieved before disassembly.
- ➡ Dispose of the components in a proper and environmentally friendly manner while adhering to all statutory and operational regulations.

The final decommissioning and disposal requires a complete disconnection of the entire power supply, the dismantling of the mechanical components and the disposal of the media that may remain in the machine.

All safety and environmental aspects must be taken into consideration when dismantling and disposing of the machine.



Risk of environmental damage!

- Observe the applicable national and regional regulations and the manufacturer's instructions when disposing of the machine.
- Segregate the different operating and auxiliary materials and dispose of them in a proper manner.



Risk of fatal injury from electric shock!

- Disconnect the power supply when carrying out the dismantling and disconnection work.
- Work to disconnect the electrical components must only be carried out by qualified electricians.



Risk of uncontrolled machine movements!

Sufficient energy reserves remain in various supply systems (e.g. electrics, electronics, pneumatics) after disconnecting the power supply (emergency stop switch) that could have dangerous consequences in the case of intervention by an unqualified person.

- Make sure that the EMERGENCY STOP switch and the compressed air are

5 Transport, Packaging and Storage

5.01 Transport to the customer's premises

All machines are completely packed for delivery.

5.02 Transport within the customer's premises

The manufacturer assumes no liability for transport within the customer's premises or to the individual usage sites. Please ensure that the machines are only transported in a vertical position. The relevant safety regulations must be observed.

5.03 Disposal of the packaging materials

The packaging materials of these machines consists of paper, cardboard and VCI fleece. It is up to the customer to dispose of the packaging properly.

5.04 Storage

The machine can be stored for up to **6** months when not in use. It must then be protected from dirt and moisture. For longer storage periods, the machine's single components, especially its sliding surfaces, must be protected against corrosion, e.g. by an oil film.

6 Work Symbols

Activities to be performed or important information in this instruction manual are emphasised by symbols. The symbols used have the following meaning:



Note, information



Cleaning, care



Lubrication

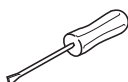

Maintenance, repairs, adjustment, service work
(only to be carried out by technical staff)

7 Operating Controls

7.01 Main switch

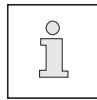

Before switching on the machine, raise the take-up lever as far as possible.

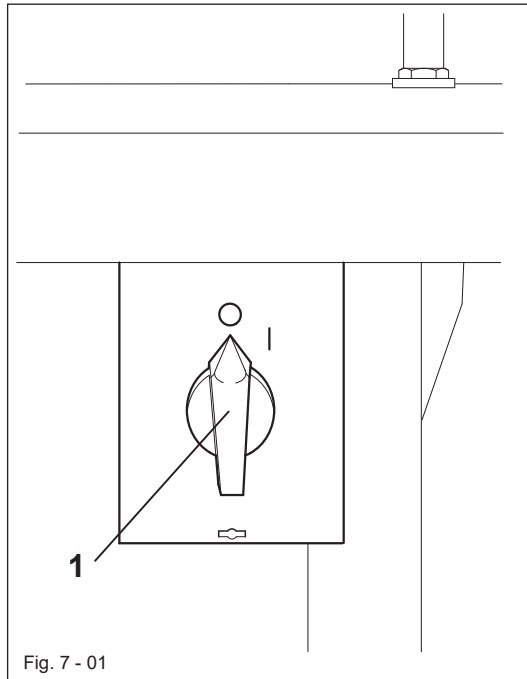

- Turning the main switch **1** switches the machine on and off.

7.02 Keys on the machine head

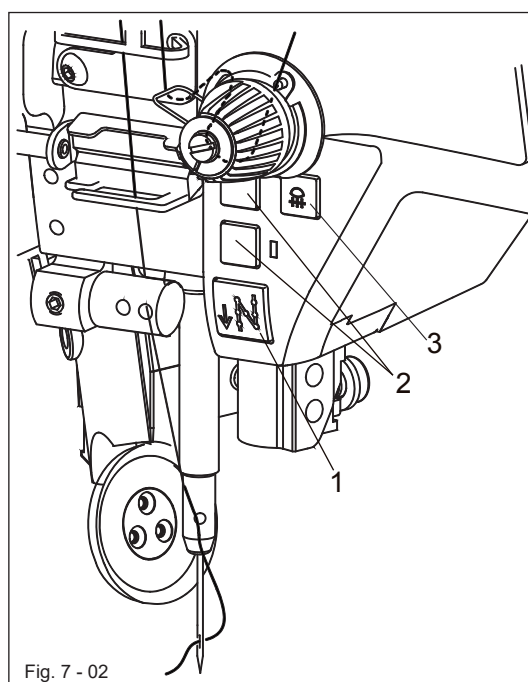

- The machine sews backwards as long as the key **1** is pressed during the sewing operation.
- The keys **2** can be assigned functions using parameters "**8005**" and "**8006**". (See chapter **11.07** Parameter settings).
- The sewing lamp integrated on the machine head is switched on and off with the key **3**.

7.03 Bobbin thread monitoring using the stitch count

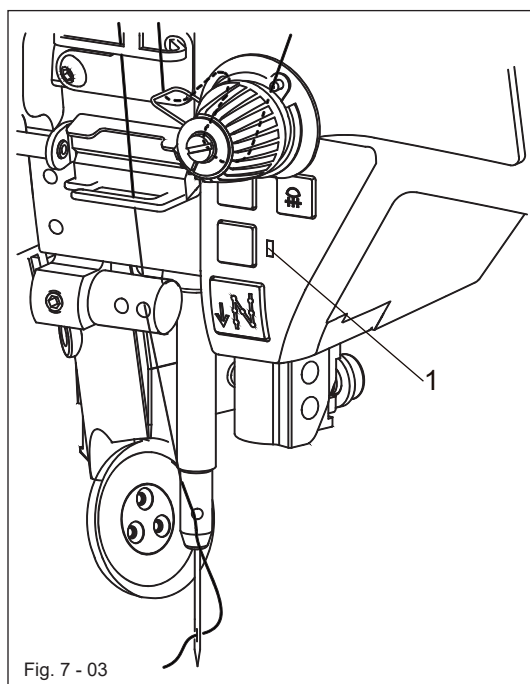

- The diode 1 flashes on reaching the predefined stitch count.
- The stitch count re-starts after trimming the thread and changing the bobbin.

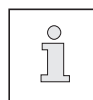

For presetting the stitch count please refer to chapter 9.10 **Setting the bobbin stitch counter.**

7.04 Pedal

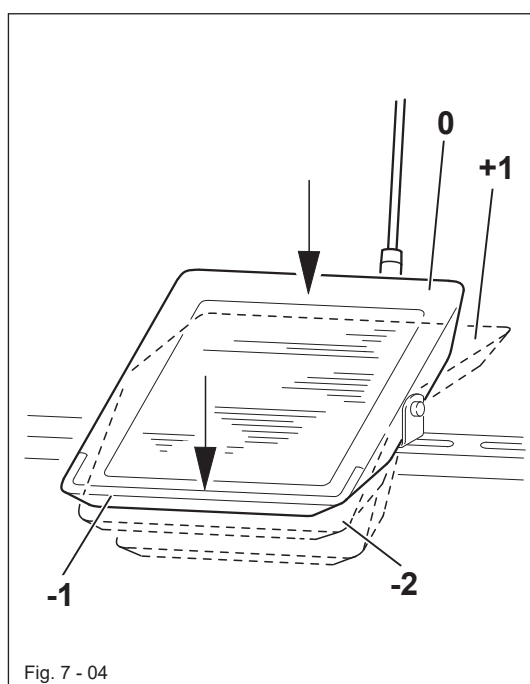

- With the main switch turned on
 - 0 = Neutral position
 - +1 = Sewing
 - 1 = Raise roller presser
 - 2 = Trim thread

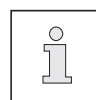

Other pedal functions can be set through the programming, see chapter 10 **Sewing.**

7.05 Hand lever to raise the roller presser

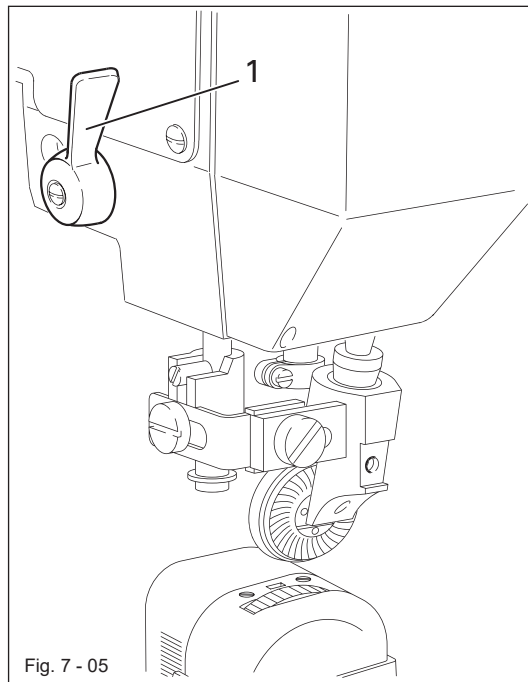

- Turning the hand lever **1** raises the roller presser.

7.06 Swivelling out the roller presser

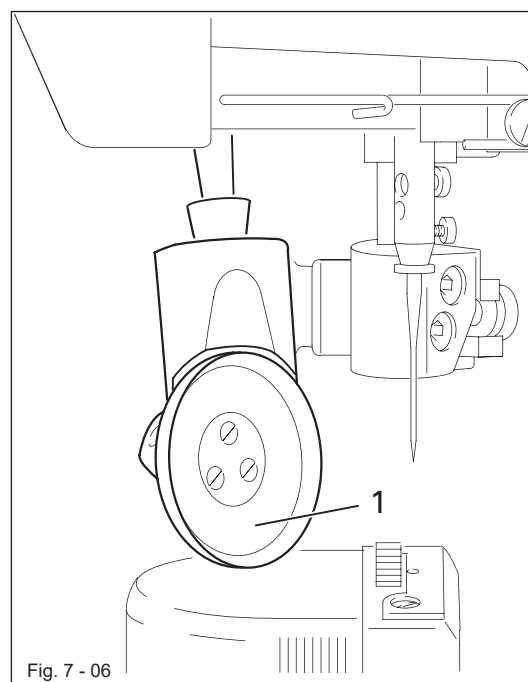

- The roller presser **1** can be swivelled out by gently pulling downwards when the roller presser is in the raised position.

7.07 Knee switch

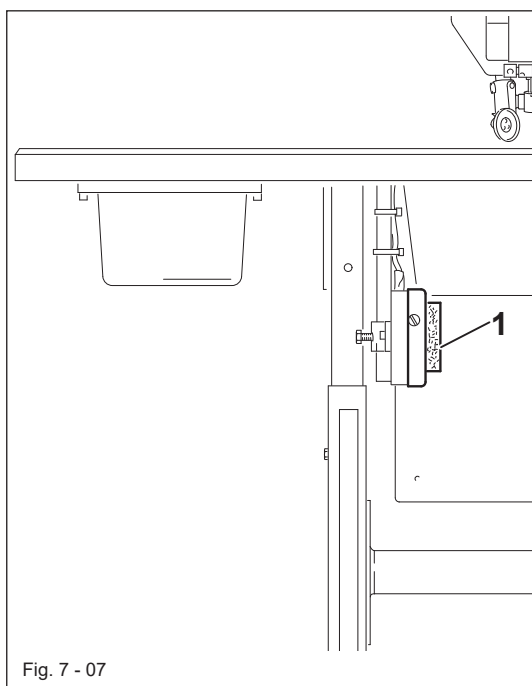

- By pressing the knee switch 1 can be selected between program 1 with 2 seam sections and different stitch length and program 2 with 3 seam sections and different stitch length.
- It is possible to move to the next seam zones in programmed sewing by using the knee switch 1.



The function of the knee switch 1 must be activated on the control panel, see chapter **10 Sewing**.

7.08 Knee lever

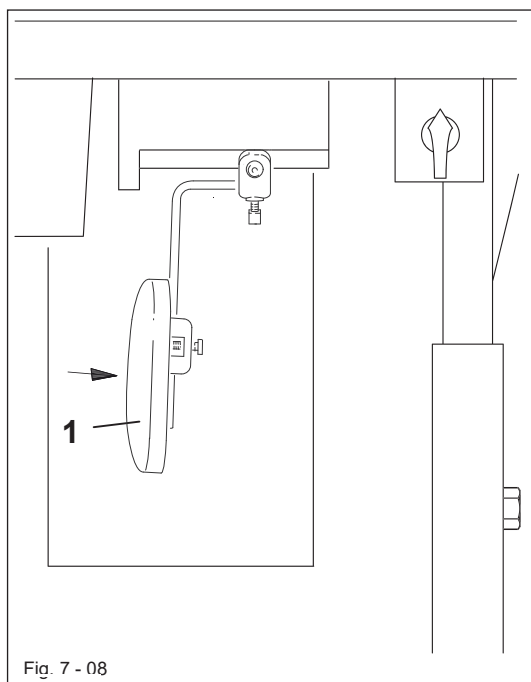

- Pressing the knee lever 1 in the direction shown by the arrow raises the roller presser.

7.09 Edge trimmer -725/04 for PFAFF 1571

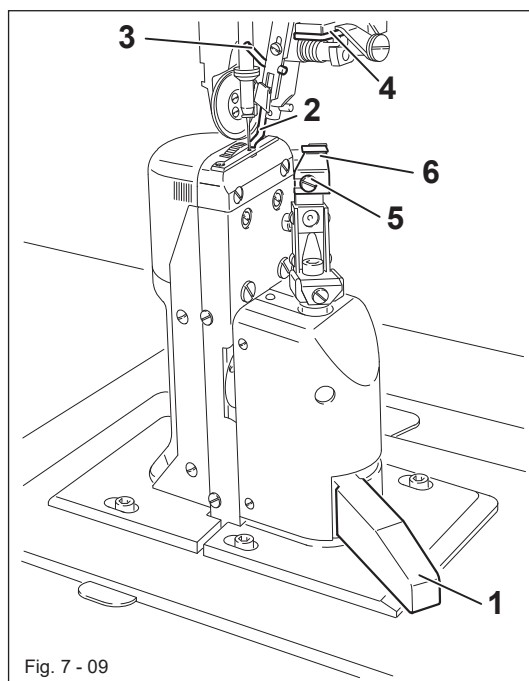

Fig. 7 - 09



Do not reach into the knife during operation! Risk of injury!

Switching on the knife drive:

- Swivel the lever **1** backwards; the knife moves to the operating position.

Switching off the knife drive:

- Press the lever **1**; the knife swivels away backwards.

Switching on the edge guide:

- Swing in the edge guide **2** by hand and press the lever **3**; the edge guide **2** moves to the operating position.

Switching off the edge guide:

- Raise the edge guide **2** and allow it to engage; the edge guide **2** is out of operation.
- Raise the lever **4**; the edge guide swivels away backwards.

Replacing knives:



The work described below may only be carried out by technical staff or people with appropriate training!

- Switch the machine off.
- Release the screw **5** and remove the knife **6**.
- Insert a new knife and gently tighten the screw **5**.
- Adjust the knife as described in chapter **15.05.05 Knife movement** of the adjustment manual and tighten the screw **5**.

7.10 Edge trimmer -725/04 for PFAFF 1591

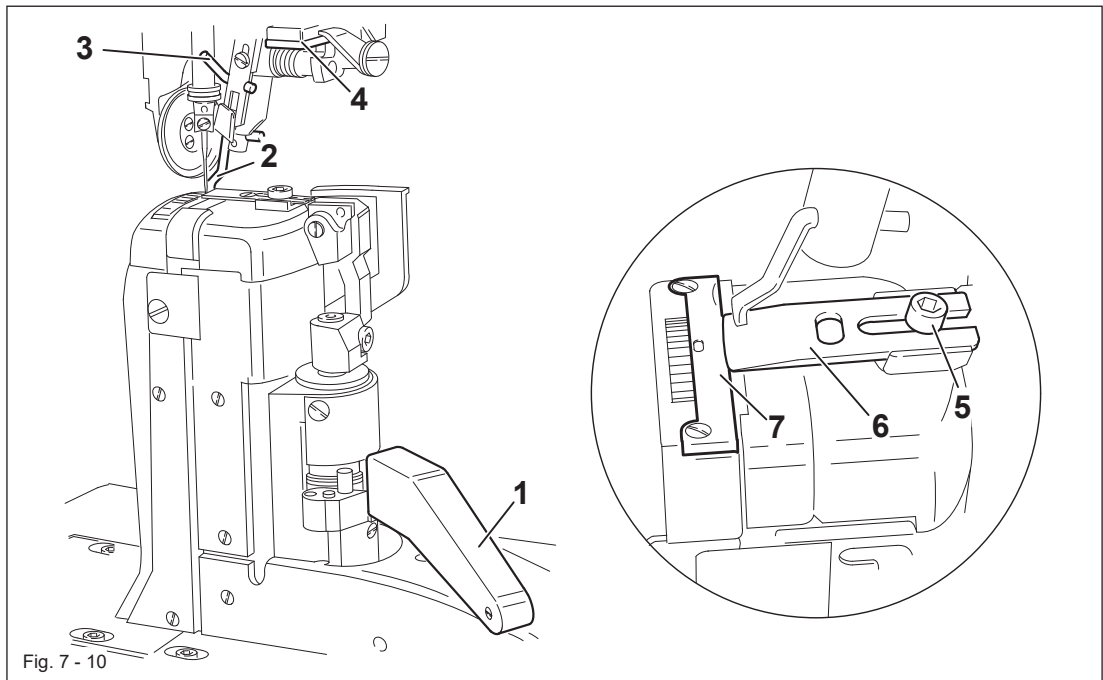

Do not reach into the knife during operation! Risk of injury!

Switching on the knife drive:

- Swivel the lever 1 backwards; the knife moves to the operating position.

Switching off the knife drive:

- Press the lever 1; the knife swivels away backwards.

Switching on the edge guide:

- Swing in the edge guide 2 by hand and press the lever 3; the edge guide 2 moves to the operating position.

Switching off the edge guide:

- Raise the edge guide 2 and allow it to engage; the edge guide 2 is out of operation.
- Raise the lever 4; the edge guide swivels away backwards.

Replacing knives:



The work described below may only be carried out by technical staff or people with appropriate training!

- Switch the machine off.
- Release the screw 5 and remove the knife 6.
- Insert a new knife and slide it fully towards the needle plate insert 7.
- Gently tighten the screw 5.
- Adjust the knife as described in chapter 15.05.07 Knife position of the adjustment manual and tighten the screw 5.

7.11 Control panel

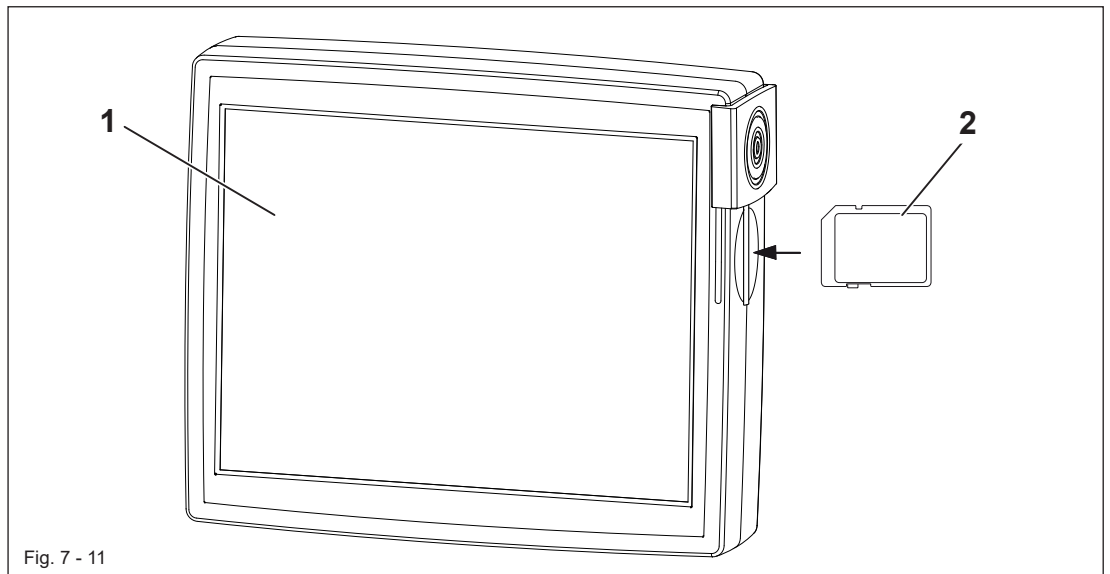



Fig. 7 - 11

The current operating status are indicated on the control panel **1**. The machine is operated with constant dialogue between the control and the operator; different pictograms and / or texts are displayed for this purpose according to the operating status of the machine. Pictograms or texts with a border represent functions that can be called up by pressing on the respective point on the monitor. Pressing the respective function causes its immediate actuation or activation/deactivation or another menu will appear, e.g. for entering a value. Activated functions are indicated by pictograms shown inversely. Apart from the bobbin change function, the pictograms and texts without border are only for display purposes and cannot be called up by pressing them. The SD card **2** in the control panel can be used to import seam programs.







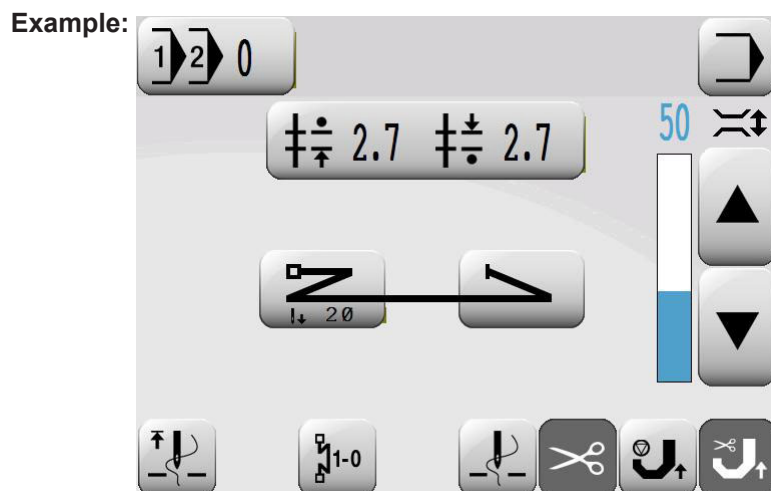













Presentation of functions





















 Normal pictogram = Function deactivated (inactive)

 Inverse pictogram = Function activated (active)





























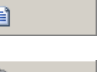









7.11.01 Function keys

-  End input and change to sewing mode
-  Call up input mode.
-  Program interruption
-  Program selection
-  Create/correct seam program
-  Teach-in
-  Service
-  Software information
-  Program management
-  Parameter input
-  Access rights
-  QONDAC network
-  Enter
-  Enter comment
-  Stop
-  Acknowledge the elimination of the error.
-  End of range pedal-controlled
-  End of range over knee button
-  End of program
-  Photo cell
-  Seam interruption

	Start
	Sew backwards
	Thread trimming
	Seam end without cutting
	Insert area
	Delete area
	Clear
	Inputs / outputs
	Motors procedure
	Cold start
	Thread tension
	Inputs / outputs
	Special Inputs
	Speed
	No start backtack
	Simple start backtack
	Double start backtack
	No end backtack
	Simple end backtack
	Double end backtack
	Needle position raised

Operating Controls

	Needle raised
	Backtack suppression
	Roller presser up
	Roller presser down after thread trimming
	Stitch length roller foot
	Feed wheel stitch length
	Reference
	Stitch count
	Target stitch position
	Rewrite directory
	To mark
	Reverse the marking
	Directory up
	Directory down
	New directory
	Select program
	End
	Memory of the machine
	SD card
	Network
	Copy
	Clear
	Display programs / machine data

- 7.11.02 Symbols
-  Current speed
 -  Seam zone
 -  Current seam zone
 -  Inputs
 -  Outputs
 -  Needle swing
 -  Thread tension
 -  Access rights
 -  Software information
 -  Stitch count
 -  Parameter input
 -  Inputs / outputs
 -  Cold start
 -  Motors procedure
 -  End of range pedal-controlled

Set-up and Initial Commissioning

8 Set-up and Initial Commissioning



The machine may only be set up and started up by qualified personnel! All of the relevant safety regulations must always be complied with in this process!
If the machine was delivered without a table, then the stand and the table top provided must safely support the weight of the machine and its motor.
Adequate stability of the stand must be guaranteed, even during the sewing operations.

8.01 Set-up

Suitable electrical supply connections must be provided at the erection site, see **chapter 3 Technical Data**. The erection site must also have a firm and level subsurface and adequate lighting.



The table top is lowered for packaging purposes.
The adjustment of the table height is described below.

8.01.01 Setting the table height

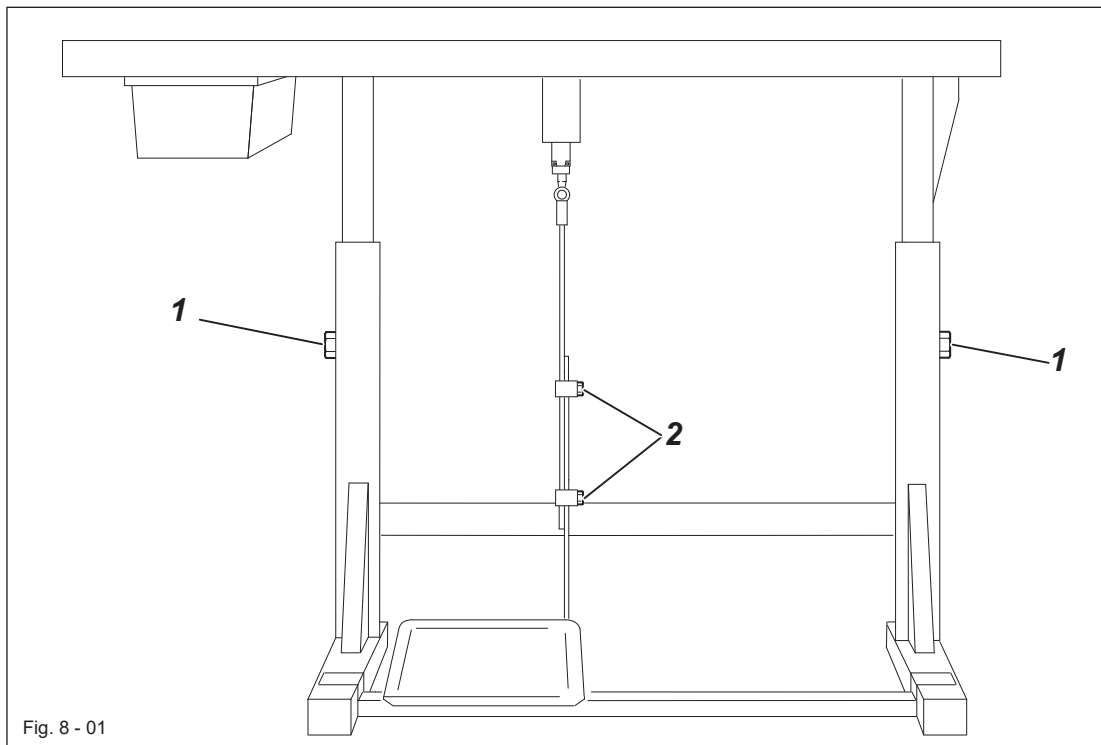

Fig. 8 - 01

- The stand must have all four feet firmly on the ground to make sure it is positioned securely.
- Loosen the screws **1** and **2**.
- Move the table top to the desired working height by pulling it out and pushing it in and align the table top horizontally.



Adjust the stand on both sides evenly to prevent it tilting.

- Firmly tighten the screws **1**.
- Adjust and tighten the desired pedal position on the screws **2**.

8.01.02 Inserting the sewing machine into the stand

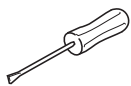
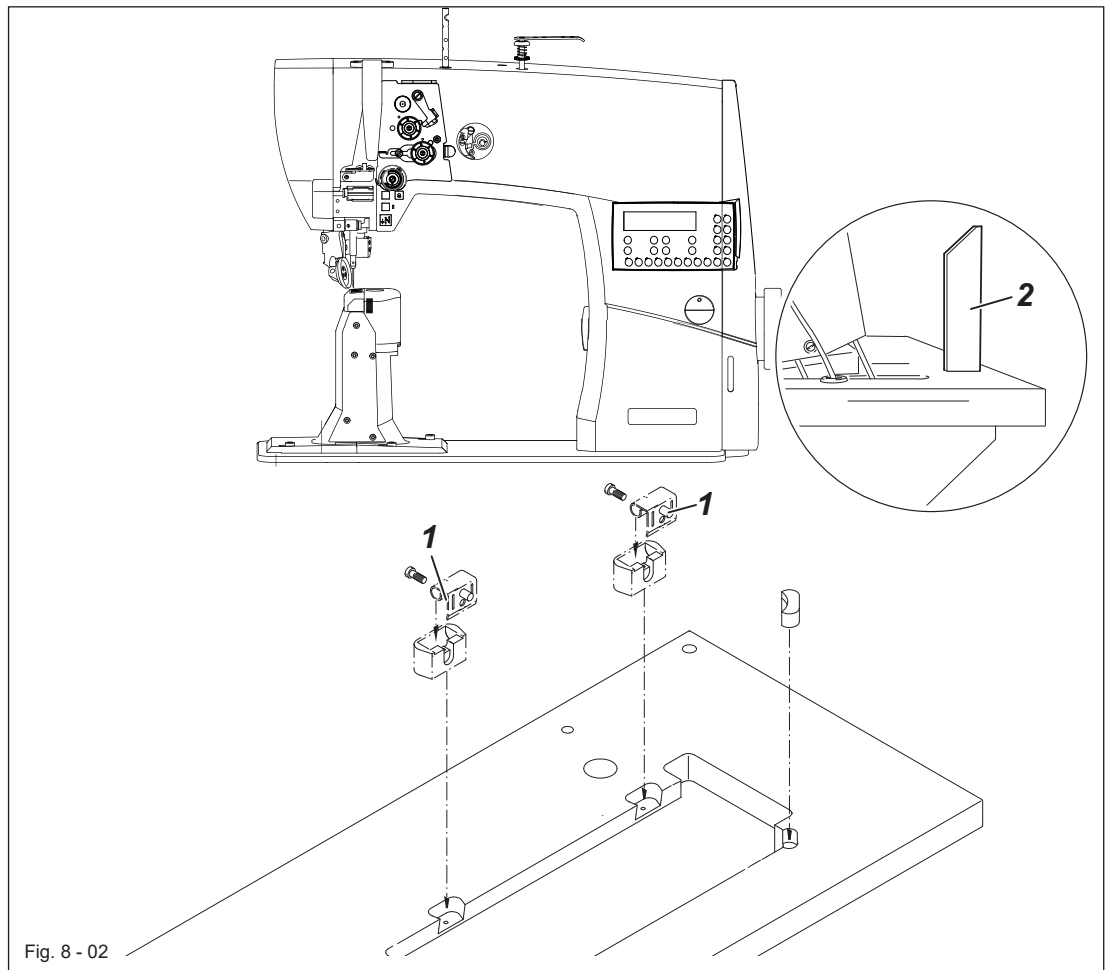

- The hinges **1** are screwed to the sewing head base plate.
- Insert the sewing machine into the table top.
- Insert the sewing head support **2** into the table top hole.



Do not operate the machine without the support **2**! Risk of damage due to the top-heavy sewing head!

Machine can tip over backwards when moving it!

Set-up and Initial Commissioning

8.01.03 Assembling the anti-tipping device

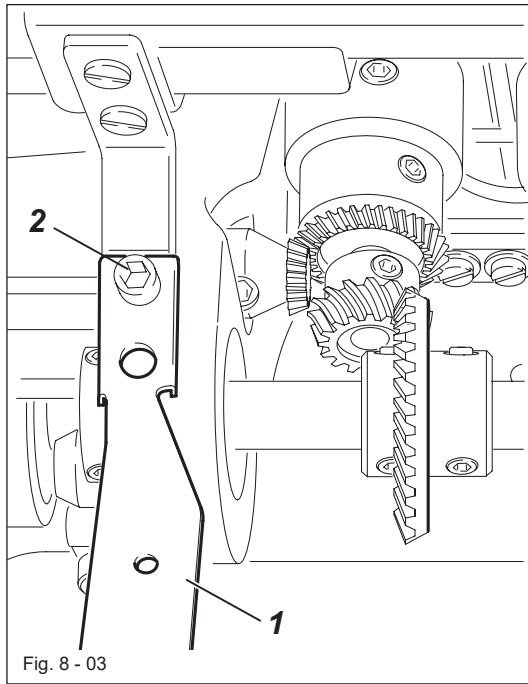

Switch off the machine!
Risk of injury due to accidental machine start-up!

- Screw on the anti-tipping device **1** included in the accessories with the screw **2**.



Do not operate the machine without the anti-tipping device **1**!
Risk of injury by crushing between the sewing head and the table top!

8.02 Mounting the flange motor

8.02.01 Mounting the flange motor on the bearing plate

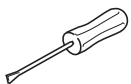
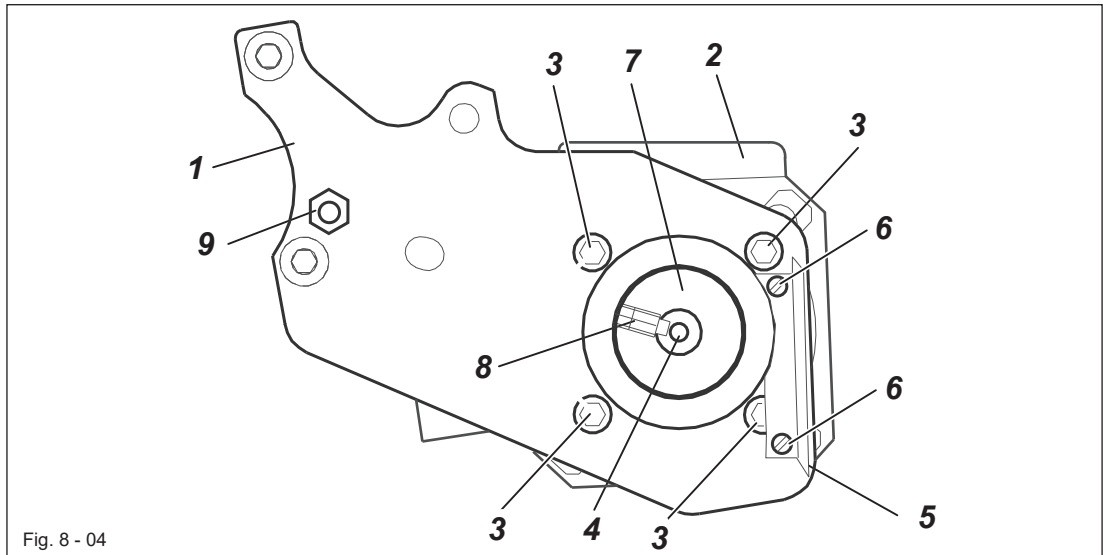

- Fix the bearing plate **1** onto the motor **2** using the screws **3**, as shown in fig. **8-04**.
- Remove the wedge from the motor shaft **4**.
- Attach the angle bracket **5** with the screws **6**.
- Mount the toothed belt wheel **7** onto the motor shaft **4** so that the screw **8** is positioned with the lug in the motor shaft slot **4**.
- Screw the threaded pins **9** into the bearing plate **1**.

8.02.02 Mounting the flange motor on the machine

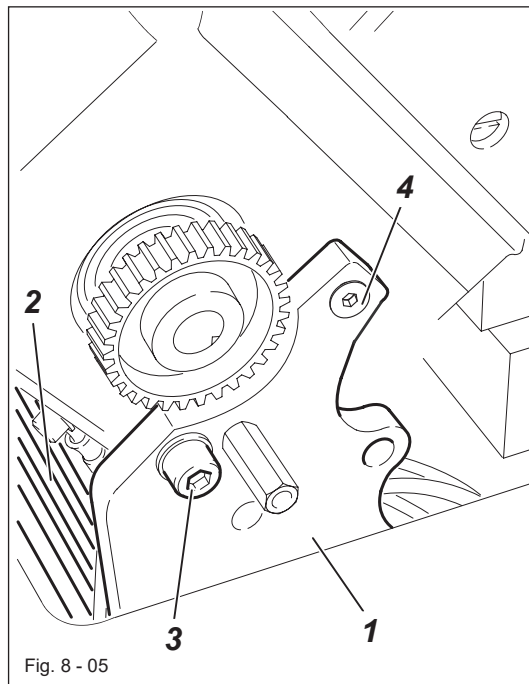

- Use the screw **3** and **4** to fix the bearing plate **1** of the motor **2** to the machine housing (tighten the screws **3** and **4** slightly).

8.02.03 Mounting the machine cover

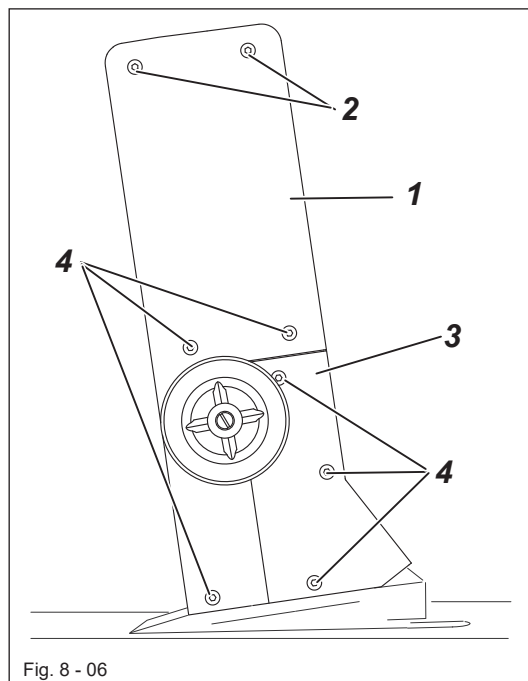

- Use the screws **2** (**2x**) and the screws **4** (**3x**) to fasten the cover **1** to the housing.
- Place the cover **3** on the cover **1** and fasten with the screws **4** (**3x**).

Set-up and Initial Commissioning

8.02.04 Connecting the plug-in connections and ground cable

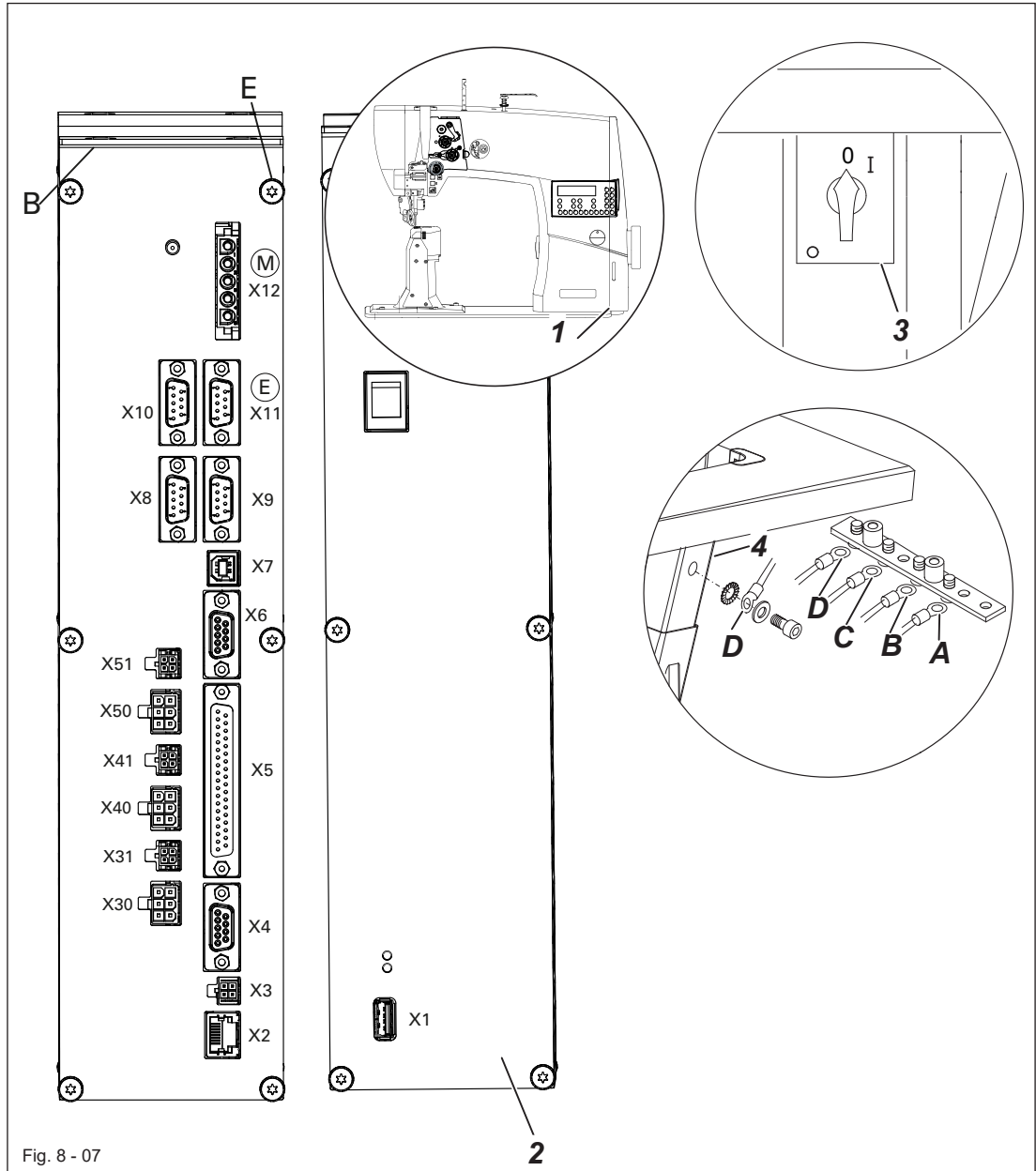
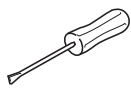

Fig. 8 - 07



- Insert all connectors on the control box **2** in accordance with their designation.
- Insert the "motor" to the bushing **E** and the bushing **M**.



Caution

Inserting the connector incorrectly can damage the control unit!

- Attach the following ground cables in order to discharge static electricity
- Securely attach the ground cable from the sewing head **1** to ground point **A**.
- Securely attach the ground cable from the control point **B** to ground point **B**.
- Securely attach the ground cable from the main switch **3** to ground point **C**.
- Securely attach the ground cable from the stand **4** to ground point **D**.
- Securely attach the ground cable from the motor cable **M** to ground point **E**.

8.02.05 Fitting the toothed belt / home position of the machine drive with the PFAFF 1571; 1591 and 1593

- Switch the machine on

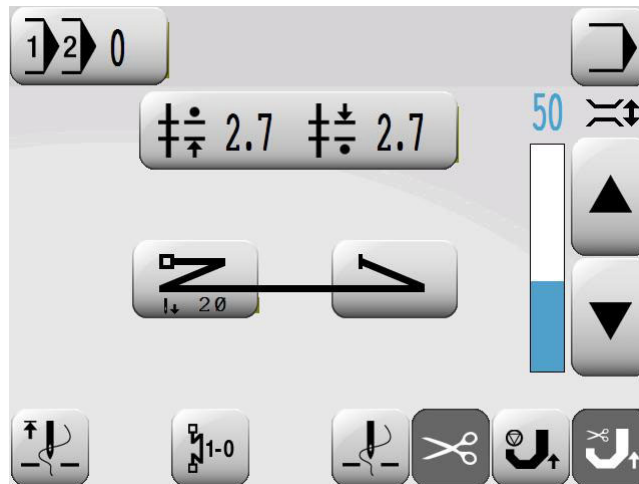

- Call up input mode.

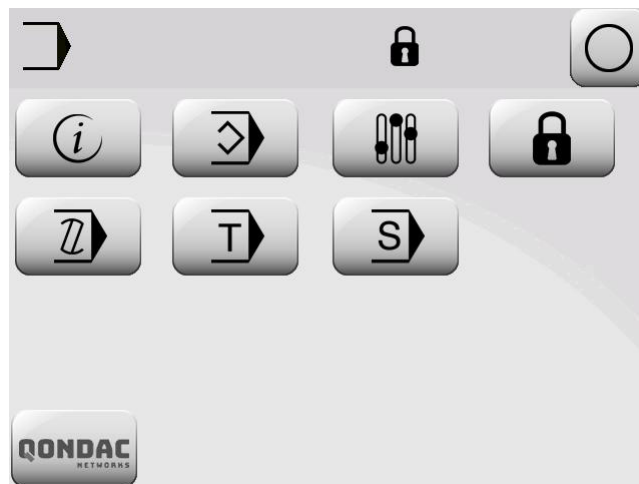

- Call up the service menu.

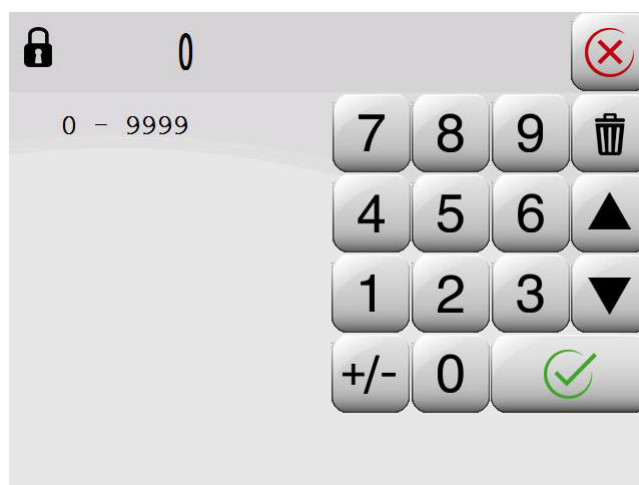

- Enter the code number using the numeric keypad (code set at the factory is "1500").

Set-up and Initial Commissioning

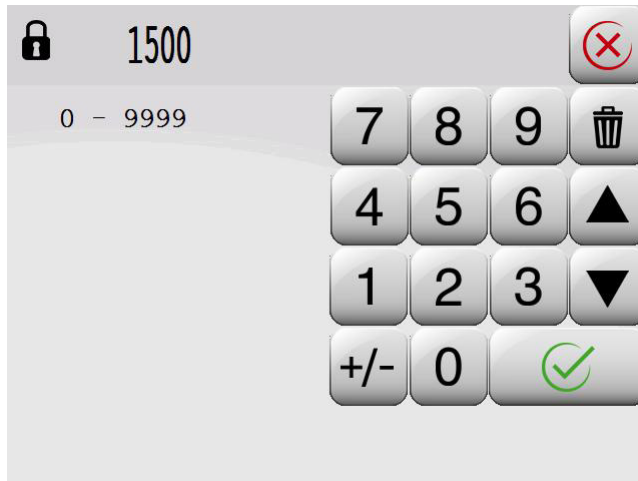

- Adopt the code number entered.

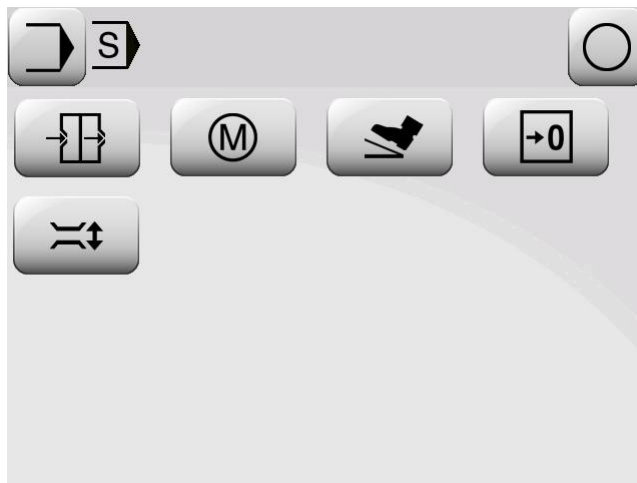

- Press the service motor button.

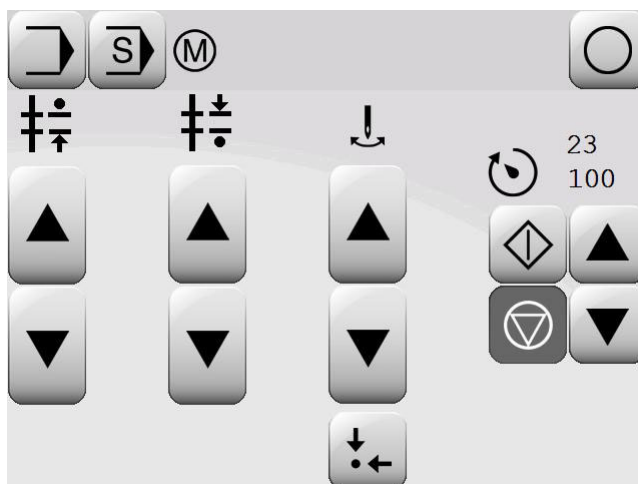

- Turn the motor shaft by hand until the display shows the value at 1571, 1591 „ $23^{\circ} \pm 6^{\circ}$ ” and at 1574, 1593 „ $31^{\circ} \pm 6^{\circ}$ ”.
- Turn the handwheel in the direction of rotation until the needle point (approaching from above) is on the upper edge of the needle plate.
- Lay on the toothed belt 1 while making sure that both the motor shaft 4 (*Fig. 8 - 08*) and the machine are not twisted.

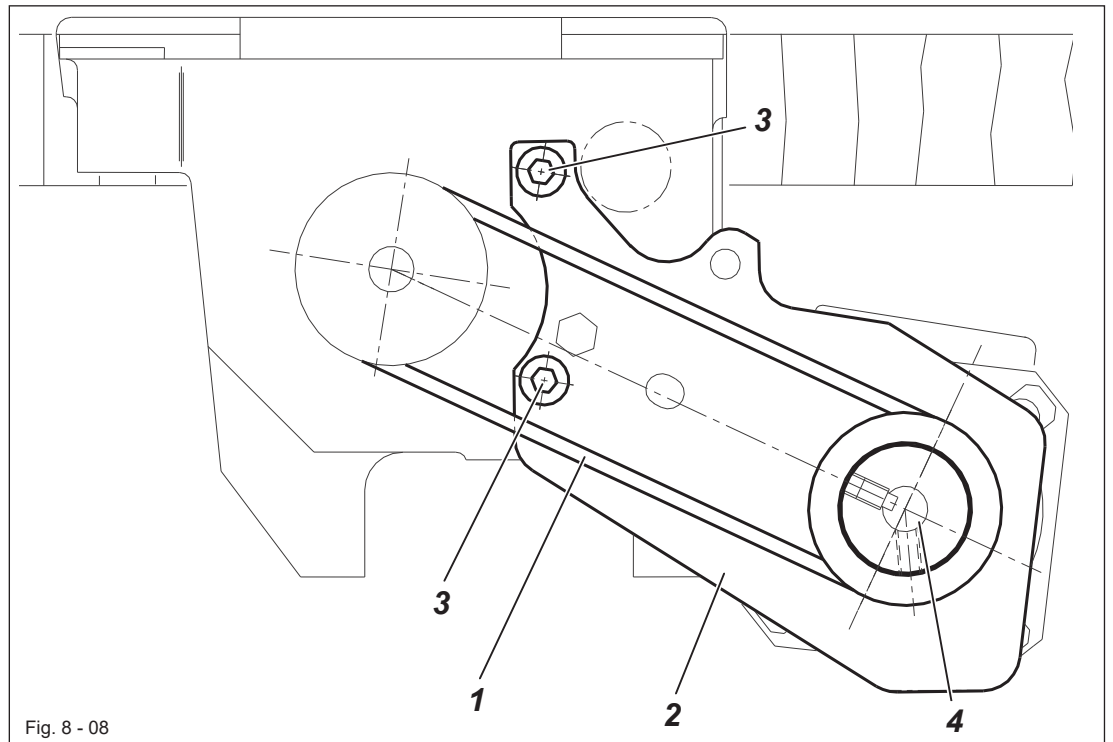



Fig. 8 - 08

- Fit the toothed belt **1**
 - Pivot the motor bearing plate **2** so that the toothed belt **1** is taut.
 - Tighten the screws **3** in this position.
 - Turn the handwheel in the direction of rotation until the needle point (approaching from above) is on the upper edge of the needle plate. ± 6 increments are permitted as a tolerance.
-  ● Complete the adjustment of the sewing motor by pressing the "Input" key.

Set-up and Initial Commissioning

8.02.06 Mounting the flange motor belt guard

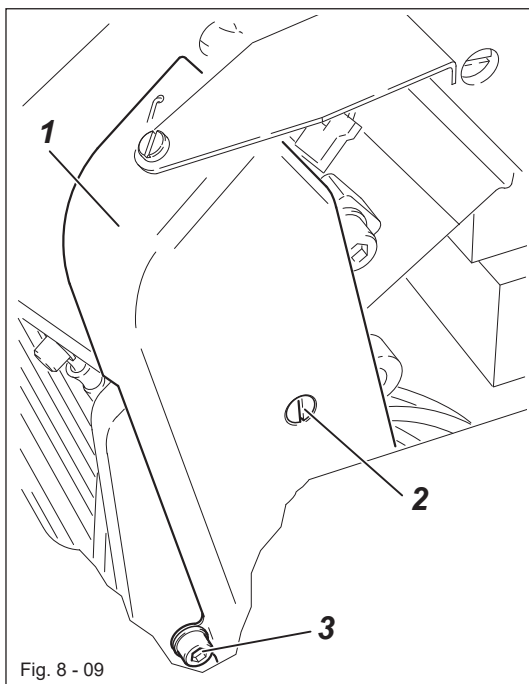

Fig. 8 - 09

- Attach the belt guard **1** with the screws **2** and **3**.

8.02.07 Connecting the safety switch

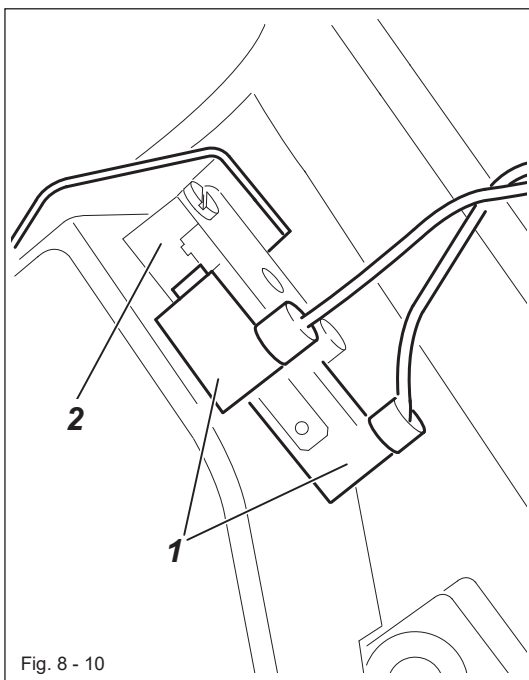

Fig. 8 - 10

- Plug in the connector **1** of the safety switch **2** as shown in Fig. **8 - 10**.



If the sewing head is tilted back, the safety switch activates the start inhibitor, preventing the machine starting up if the main switch is turned on.

8.02.08 Checking the start inhibitor function

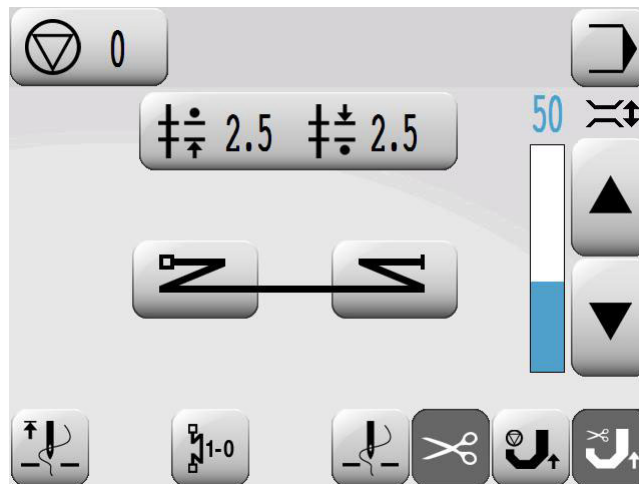

- Switch on the machine at the main switch and move the sewing head.
- The error message “**STOPP**” must appear on the control panel.
- If this message does not appear, check the switch **2** setting.
- The machine is ready for operation again after righting the sewing head.

8.03 Assembling the reel stand

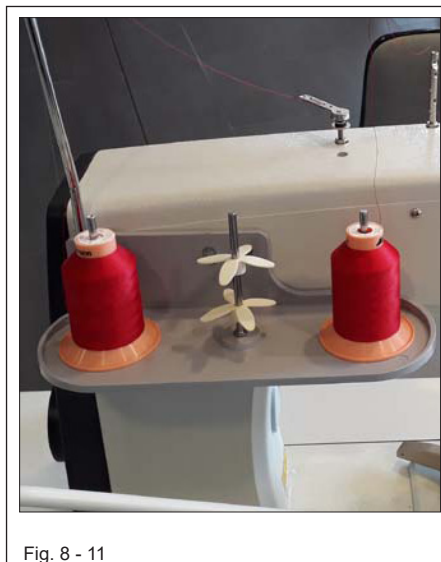

Fig. 8 - 11

- Assemble the reel stand as shown in the adjacent illustration.

Set-up and Initial Commissioning

8.04 Initial start-up

- Inspect the machine for any damage, particularly the electric cables.
- Clean the machine thoroughly and then oil it, see also **chapter 12 Maintenance and Care**.
- Arrange for technical staff to check whether the machine's motor may be operated at the existing mains voltage and whether it is connected properly.



Never operate the machine if there are any differences.



The machine must only be connected to a grounded socket!



Arrange for the home position of the machine drive to be verified by certified technicians before the initial start-up! Have these settings carried out where required.

8.05 Switching the machine on / off

- Switch the machine on (see **chapter 7.01 Main switch**).

9

Set-up



Observe and comply with all regulations and information in this instruction manual.

Pay particular attention to all safety regulations!



All set-up work may only be carried out by appropriately instructed personnel. Disconnect the machine from the electricity mains for all set-up work by operating the main switch or by removing the mains plug!

9.01

Inserting the needle

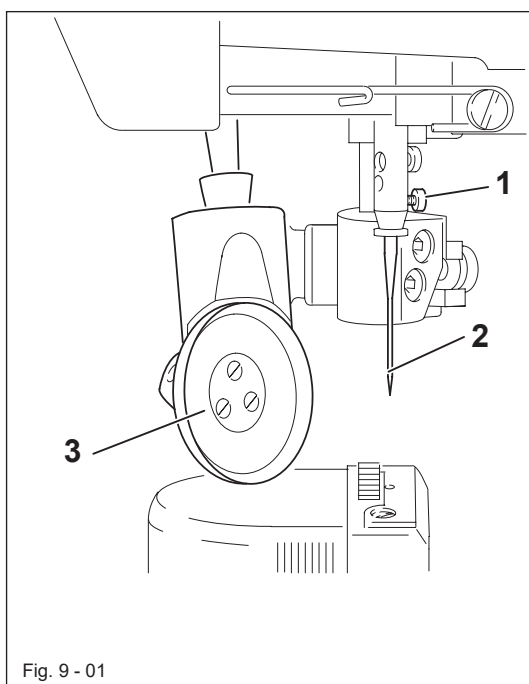

Switch off the machine!

Risk of injury due to accidental machine start-up!



Only use needles of the system intended for the machine, see **chapter 3 Technical Data!**

- Raise and fold out the roller presser **3**.
- Move the needle bar to the top position.
- Loosen the screw **1** and insert the needle **2** until you feel it stop. The long groove must point to the **left**.
- Tighten the screw **1**.

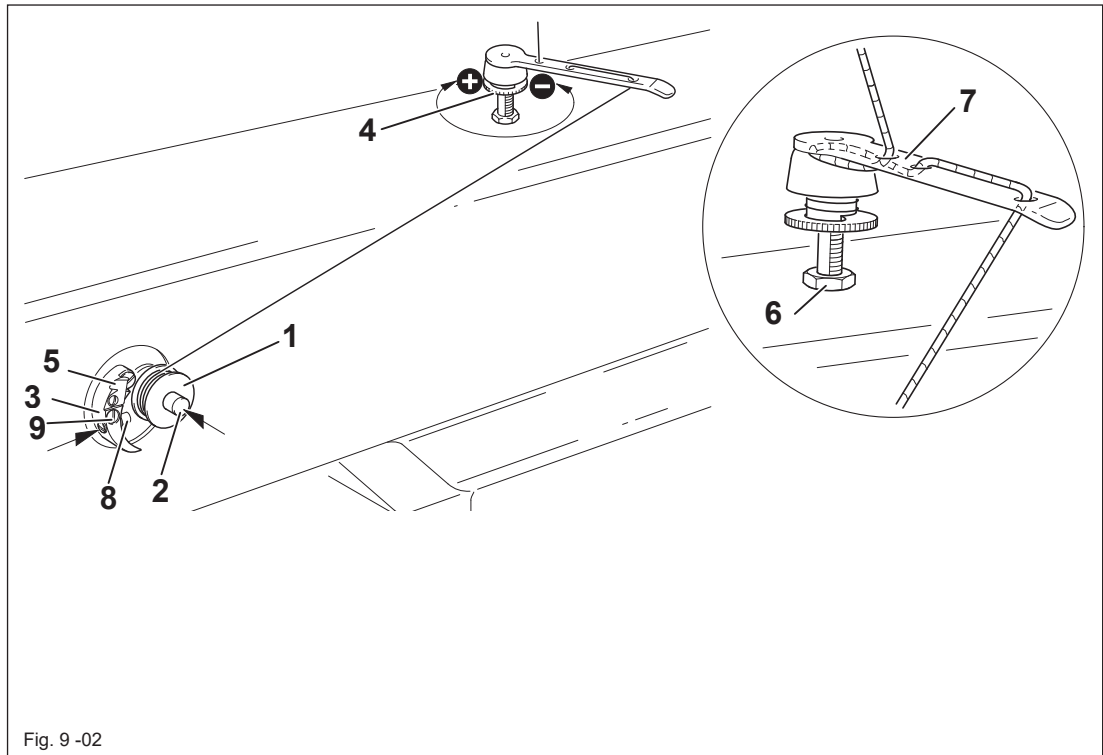

9.02 Winding the bobbin thread, adjusting the thread tension

- Fit the empty bobbin 1 onto the bobbin winder spindle 2 with the rest thread chamber on the outside.
- Thread in the thread as shown in Fig. 9 - 02 and wind it round the bobbin 1 a few times in an anti-clockwise direction.
- Switch on the bobbin winder by pressing the bobbin winder spindle 2 and the lever 3 simultaneously.



The bobbin fills up during sewing.



If the machine is only run for bobbin winding (without sewing), a bobbin case must be fitted in the hook!

Otherwise a jammed thread may damage the hook!

- The tension of the thread on the bobbin 1 can be adjusted with the knurled thumb screw 4.
- The bobbin winder stops automatically when the bobbin 1 is sufficiently full.
- Remove the filled bobbin 1 and cut the thread with the knife 5.
- The fill amount of the bobbin 1 can be adjusted with the pin 8 (loosen the screw 9 and tighten it again)

If the thread is wound unevenly:

- Loosen the nut 6.
- Turn the thread guide 7 accordingly.
- Tighten the nut 6.

9.03 Removing / inserting the bobbin case

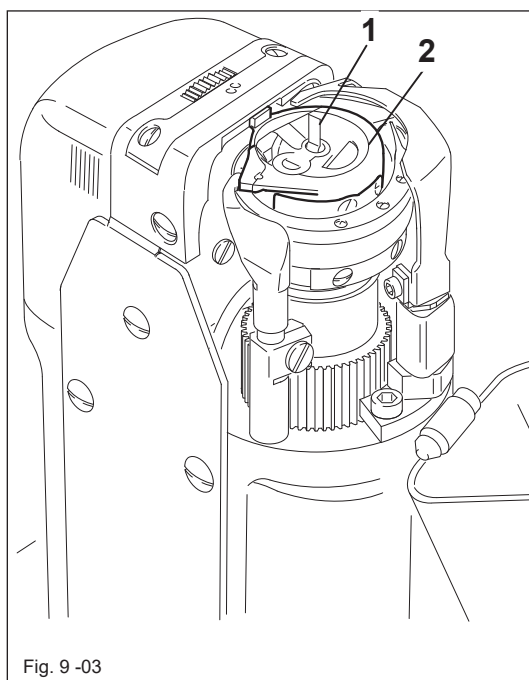

Switch off the machine!
Risk of injury due to accidental machine start-up!

Removing the bobbin case:

- Move the take-up lever to its top position
- Open the post cover, raise the lever 1 and remove the bobbin case 2.

Inserting the bobbin case:

- Press the bobbin case 2 until you feel it snap into the bobbin case base.
- Move the lever 1 and close the post cover.



Do not operate the machine with an open post cover!
Risk of injury due to moving parts!

9.04 Inserting the bobbin case, adjusting the bobbin thread tension

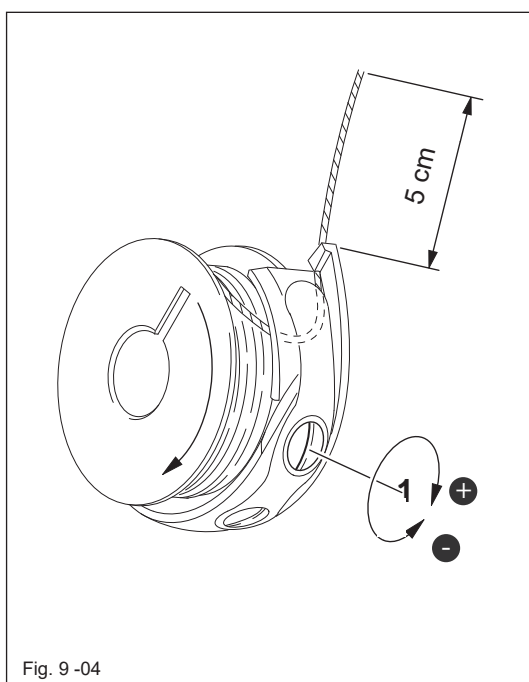

Switch off the machine!
Risk of injury due to accidental machine start-up!

- Insert the bobbin as shown in **Fig. 9 - 05**
- When the thread is drawn off, the bobbin must turn in the direction shown by the arrows.
- Adjust the thread tension by turning the screw 1.

9.05 Threading the needle thread / adjusting the needle thread tension

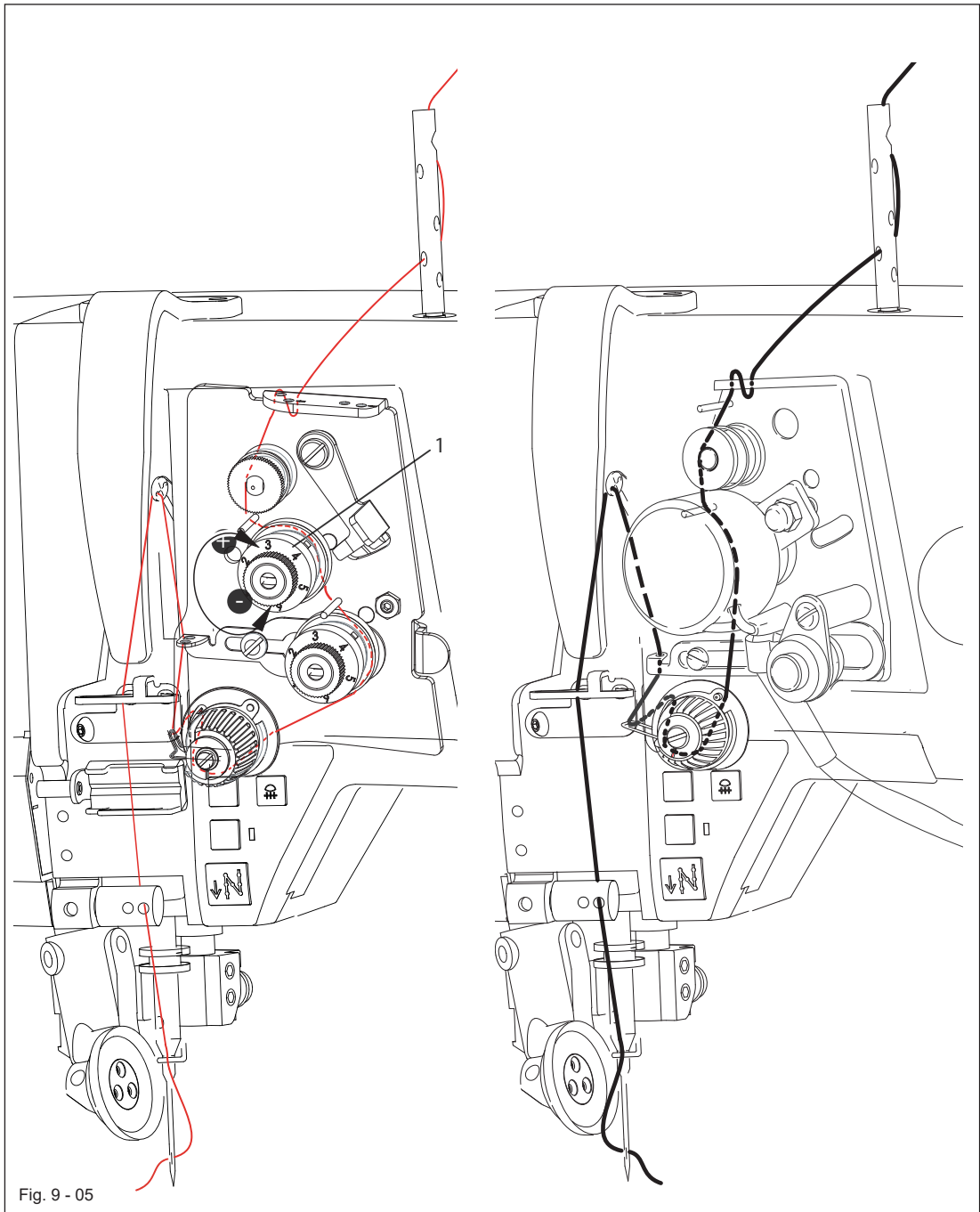

Switch off the machine!

Risk of injury due to accidental machine start-up!

- Thread the needle thread as shown in Fig. 9 - 05. Please ensure that the PFAFF 1571 needle is threaded from **right to left** and that of the PFAFF 1591;1593 is threaded from **left to right**.
- Adjust the needle thread tension by turning the knurled thumb screw 1.

9.06 Selecting a program number

- Switch the machine on.

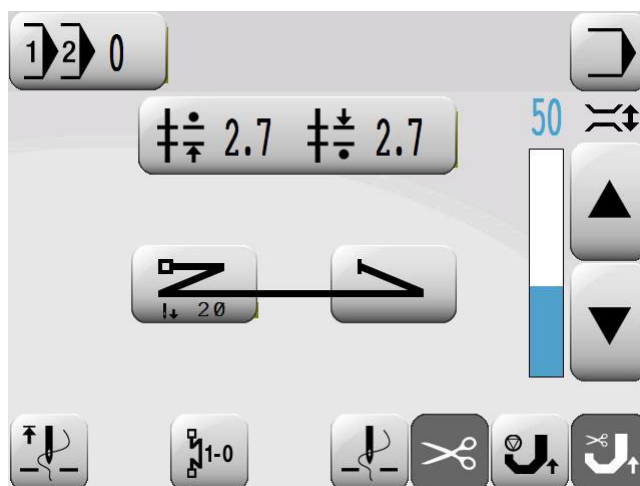

- Call up the menu to input the program number.

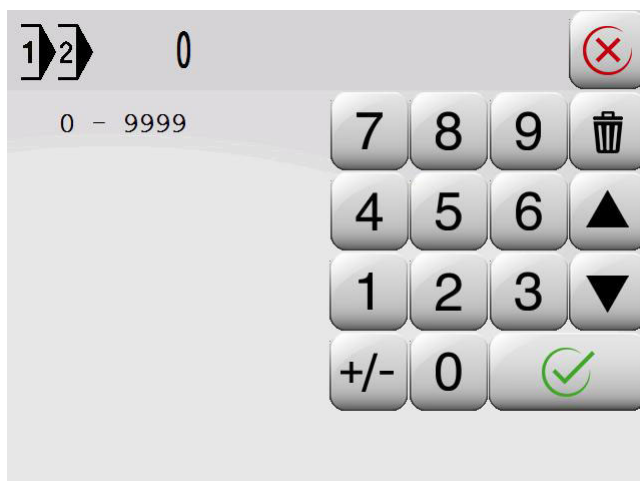

- Select the desired program number or enter it via the keypad

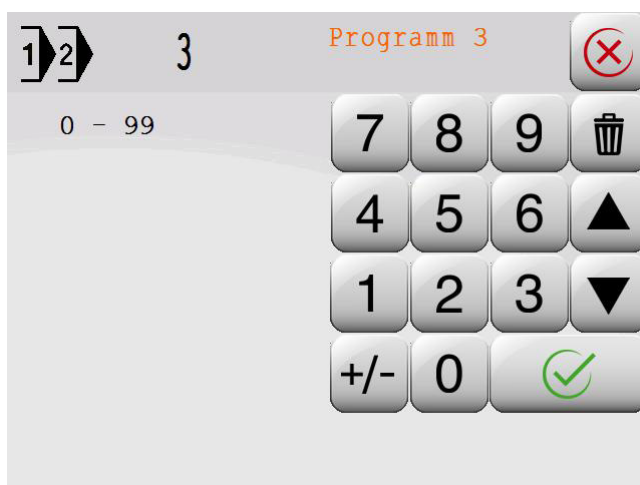

- Confirm the selection and leave the selection menu.

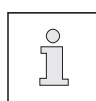
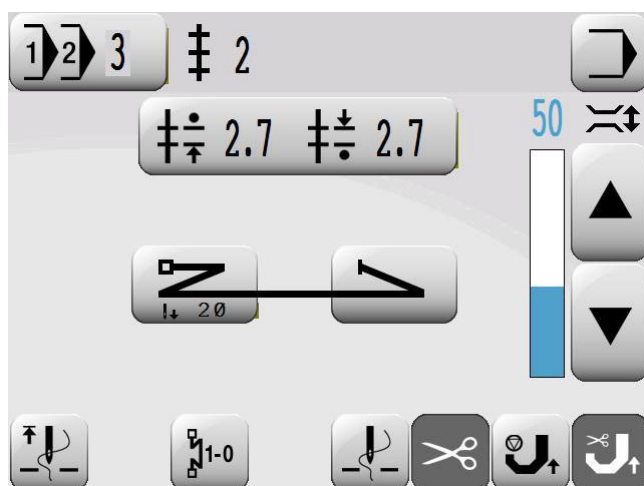

The selection of the program number determines the type of sewing, see **chapter 10 Sewing**.

Program number **0**: Manual sewing

Program numbers **1** and **2**: Sewing with suture lines

Program numbers **3** to **49**: Programmed sewing

9.07 Setting stitch lengths

The feed motion of the roller presser and feed wheel can be changed directly in manual sewing and in the seam sections 1 and 2.

- Switch the machine on.

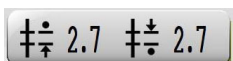
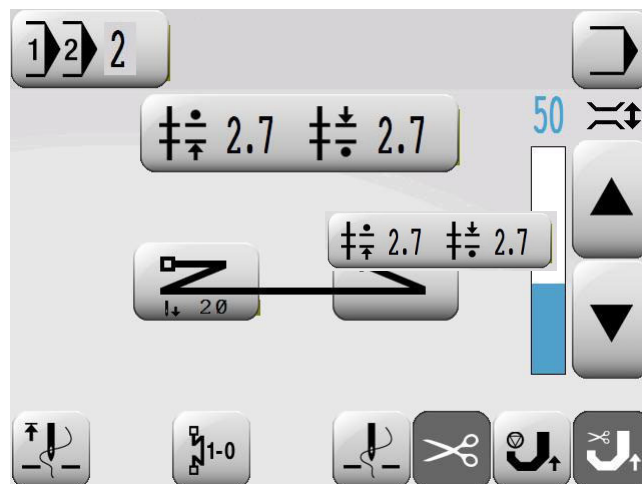

- Call up the stitch length input menu.

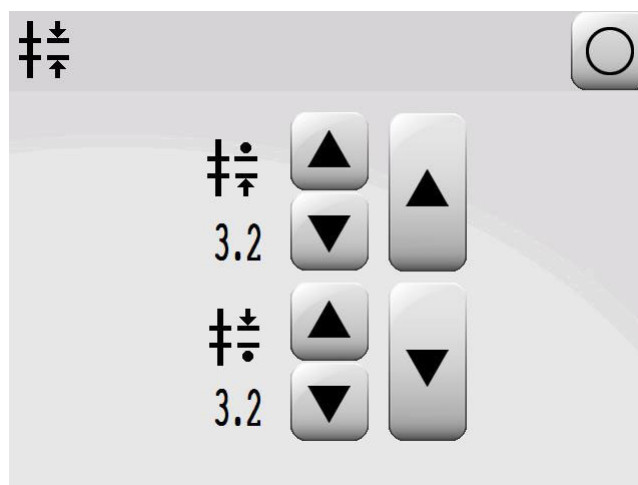

- Change the feed motion for the roller presser and feed wheel individually.

or



- Change the feed motion for the roller presser and feed wheel at the same time..



- Conclude the input.

9.08 Entering start and end backtacks

The selection of the start and end backtacks and the input of the associated values are made directly in manual sewing and in the fixed programs 1 and 2. A placed stitch can also be defined for the seam start in addition to the backtacks.

- Switch the machine on.

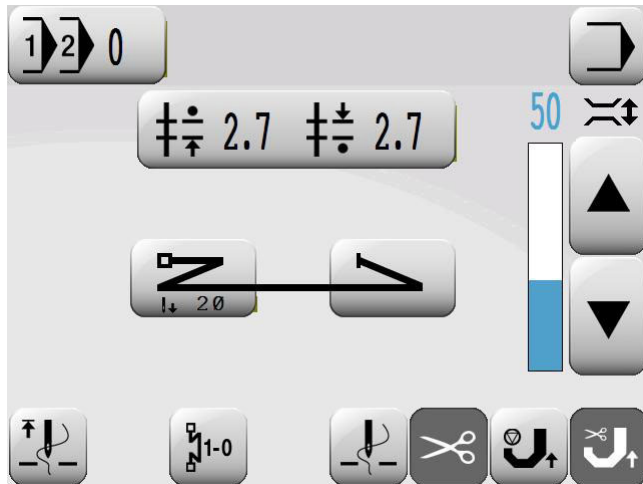

- Call up the menu for inputting the start backtack.

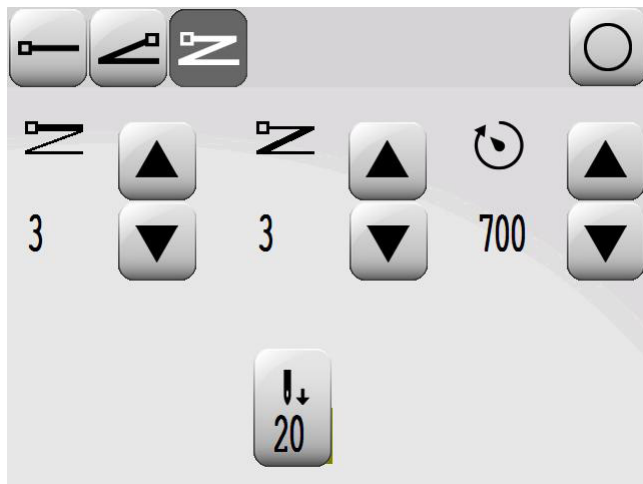

- Select the desired type of start backtack, the selected (active) function is displayed inversely:



- No start backtack



- Simple start backtack



- Double start backtack



- Enter the number of stitches for forward and reverse stitches.



- Enter the backtack speed.



- When the function is active (symbol inverse), the needle position can be adjusted by turning the handwheel.



- Conclude the start backtack input.

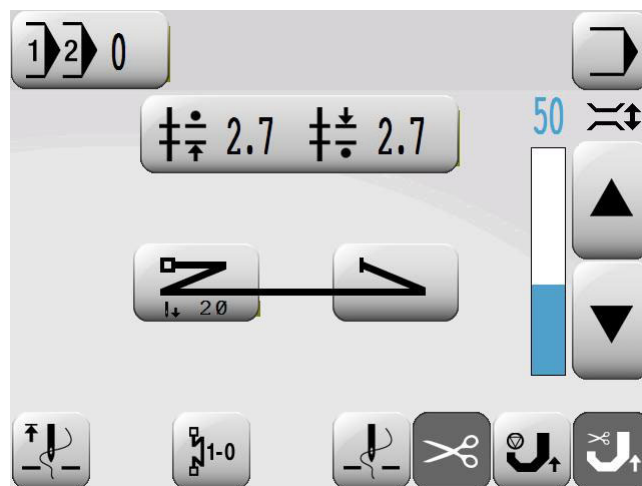

- Call up the menu for inputting the end backtack.
The values for the end backtack are entered in the same way as for entering the values for the start backtack. The pedal-controlled backtack speed and the placed stitch position cannot be called up at the seam end.

9.09 Switching on / setting the bobbin thread monitoring using stitch counting

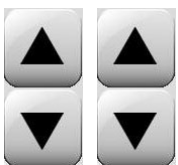
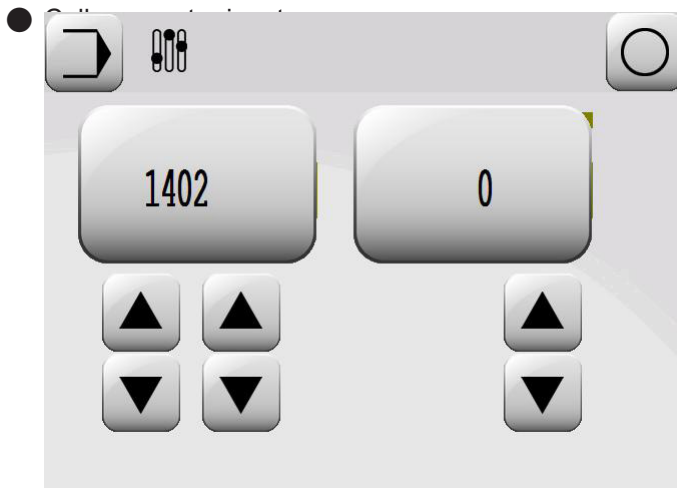
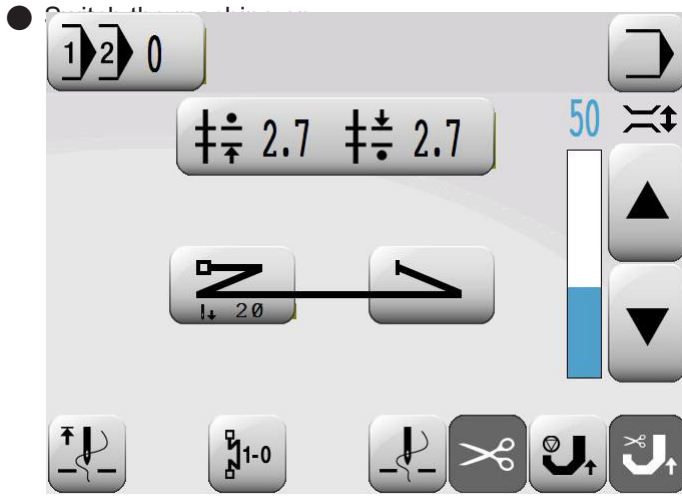

- Call up parameter '2201'.

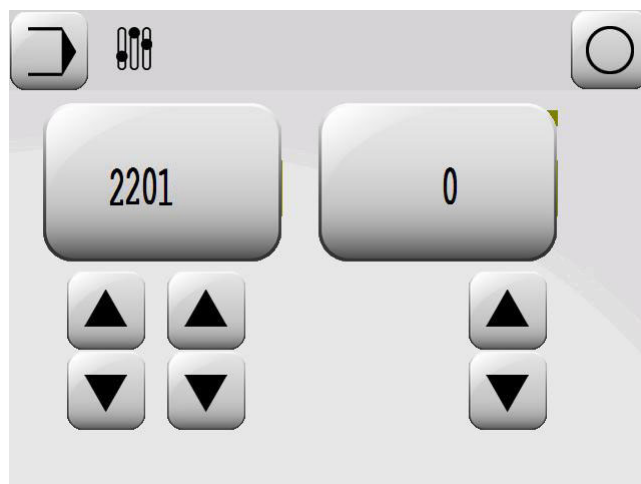

- If necessary, Enter the code number, see **chapter 9.10 Entering / changing the code number**.

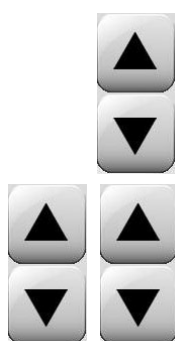

- Switch on bobbin thread monitoring via stitch counting (value "1").

- Call up parameter "2210"

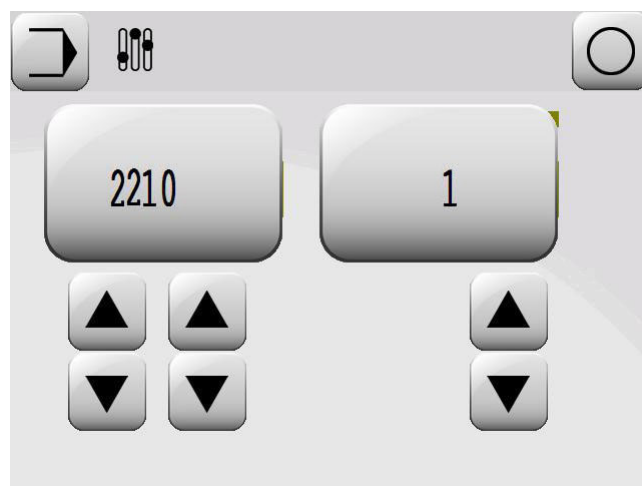

- Enter the number of stitches that can be sewn with a bobbin, for example **12000**

or



- Click on the button, eg enter 12000

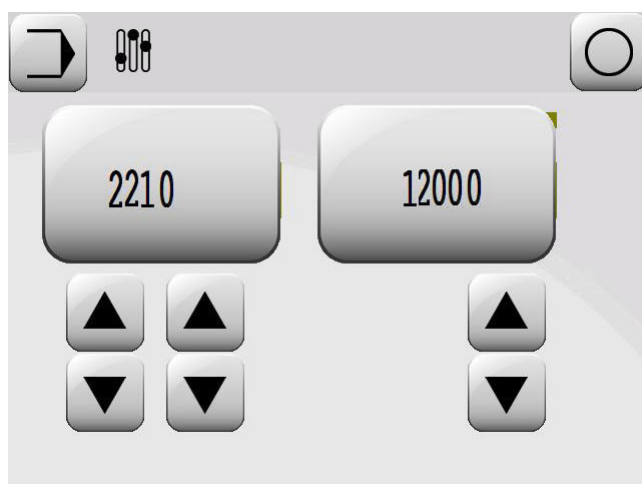

- Conclude the input.

The diode flashes on the keypad on the machine head on reaching the stitch count entered. The “” message appears on the display after thread trimming.

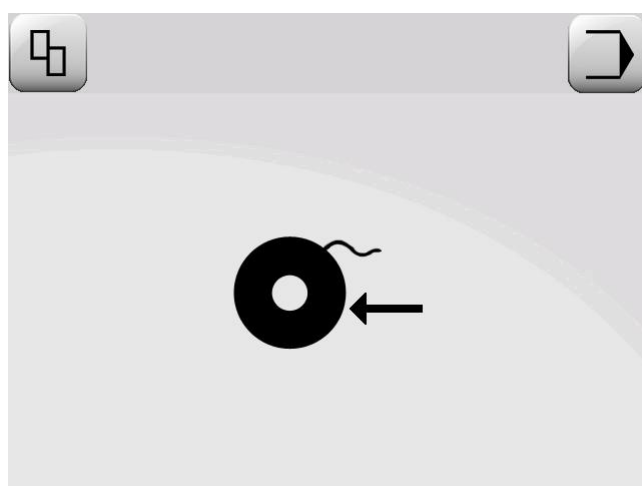

- Confirm the error correction after changing the bobbin.

9.10 Entering / changing the code number

- Switch the machine on

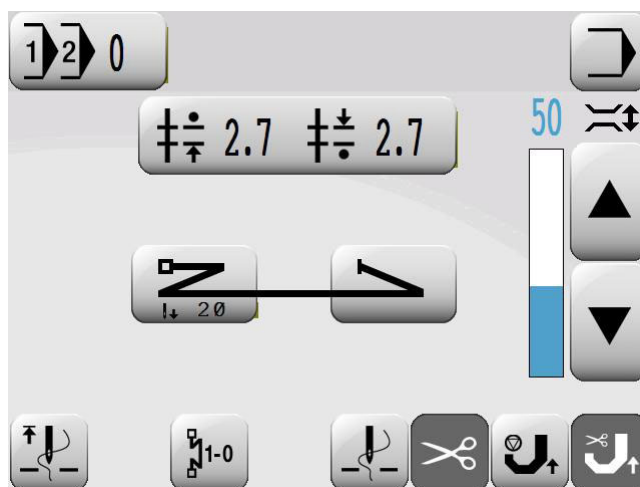

- Call up input mode.



- Call up the service menu.

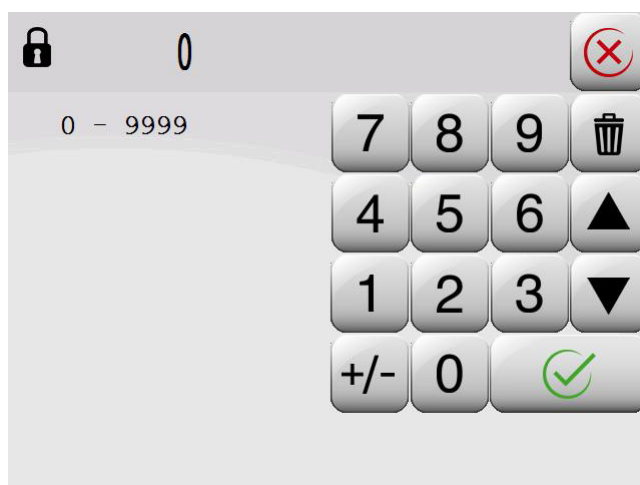

- Enter the code number using the numeric keypad (code set at the factory is "1500").

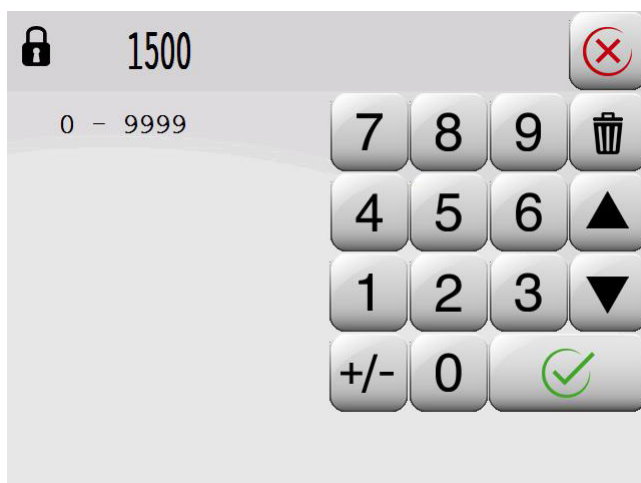

- Adopt the code number entered.



The code entered remains saved until the machine is switched off by the main switch. Provided that the machine is not turned off, all parameters can be accessed without re-entering the code number.



Remember the code!

Protected functions cannot be called up without the corresponding code! In this case, request support from the PFAFF service centre.

9.12 Inserting and removing the SD memory card

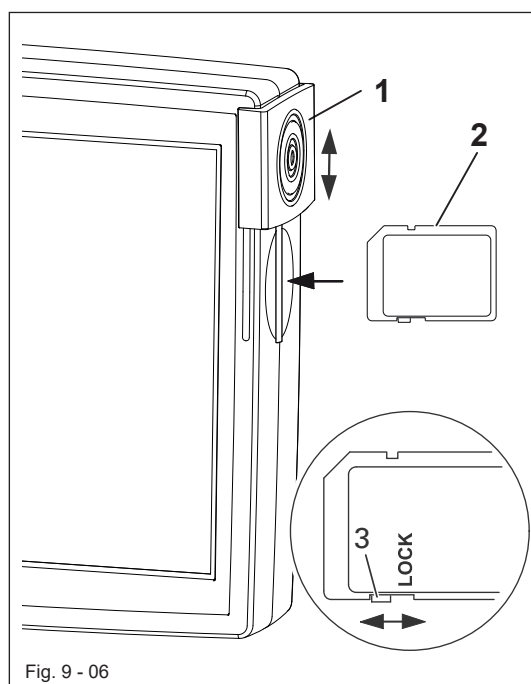

Fig. 9 - 06

Insert the SD card

- Open the cover **1**.
- Insert the SD card **2** into the card slot with the label facing forwards.
- Close the cover **1** again.



Only use FAT 16 format memory cards.

Remove the SD card

- Open the cover **1**.
- Press gently on the corner of the SD memory card **2** - the SD card will be ejected.
- Close the cover **1** again.



Adjusting the slide **3** makes it possible to activate ("LOCK" position) or deactivate the write protection function on the SD memory card. The write protection function must be deactivated to store, edit or delete data on the SD memory card.

- The SD card must be kept for future boot processes.
- The SD card is not a default configuration.

10 Sewing

In sewing mode, all settings relevant to the sewing operation are shown on the display and can be altered there directly using the corresponding function. In the sewing mode a difference must be made between manual sewing, sewing with fixed programs and programmed sewing.

The selection is made by selecting the corresponding program number:

- 0:** Manual sewing
- 1 and 2:** Sewing with fixed programs
- 3 to 49:** Programmed sewing
(with up to **15** seam zones for left and right seams)

10.01 Manual sewing

The values for the feed motion (stitch lengths) of the bottom feed (feed wheel) and top feed (roller presser), start and end backtacks, placed stitch position when sewing, thread tension and the needle and foot positions are displayed on the control panel in manual sewing and can be changed directly. Fullness can be controlled via the stitch length input on the control panel or using the left pedal. If the fullness is called up via the left pedal, the current value of the fullness appears as a bar graph display below the stitch length indicator on the display.

- Switch on the machine and select program number “0”, see **chapter 9.06 Selecting a program number**.

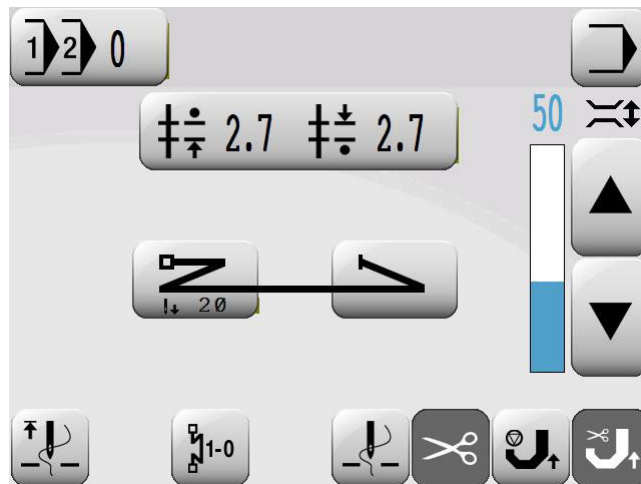

Description of the functions



Program selection

Opens the menu for inputting the program number, see **chapter 9.06 Selecting a program number**.



Input mode

Quit the sewing mode and call up input mode.



Stitch lengths

Opens the menu for entering the feed motion for the roller presser and feed wheel, see **chapter 9.07 Adjusting stitch lengths**.



Start backtick

Opens the menu for entering the seam start, see **chapter 9.08 Entering start and end backticks**.



End backtick

Opens the menu for entering the seam end, see **chapter 9.08 Entering start and end backticks**.

Needle raised



Positions the needle in the top position (thread lever t.d.c.)

Backtick suppression



When pressed once, the next backtick is suppressed.

When pressed twice, the next two backticks are suppressed.

Needle position raised



If this function is on, the needle moves to the top position when sewing stops (thread lever t.d.c.)

Thread trimming

When the function is activated, thread trimming with the pedal function is possible.



Roller presser up

When this function is activated, the roller presser is raised after sewing stops.



Roller presser down after thread trimming

When this function is activated, the roller presser is not raised after thread trimming.



Regulated thread tension with touch

By pressing the arrow keys for the thread tension (compare pictures: manual sewing, fixed program 1 and fixed program 2) the thread tension is changed directly. The setting range is between 0 and 100. In addition to the numerical value, the set value is represented by a bar display.



● Sewing is carried out using the pedal functions, see **chapter 7.04 Pedal**.

10.02 Sewing with fixed programs

Fixed programs are set under program numbers **1** and **2**. The fixed programs are used for the quick and easy sewing of seams with a different number of stitches or fullness. When sewing with fixed programs, **2** or **3** seam zones are processed one after the other. Pressing the knee switch moves the machine to the next seam zone. The fixed programs are designed as concentric programs, meaning after the end of the last seam zone, the first seam zone is started again. The values for the feed motion of the bottom feed (feed wheel) and the top feed (roller presser) can be changed for each individual sewing area. The values for the start and end locking, placed stitch position when sewing, needle and foot positions and the thread tension apply across the entire area and can be changed at any time.

- Switch on the machine and select program number “1” or “2”, see **chapter 9.06 Selecting a program number**.

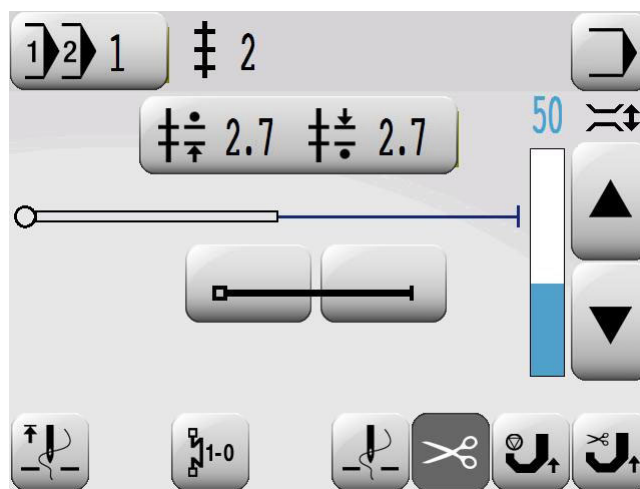

Explanation of the displays and functions



Program selection

Opens the menu for inputting the program number, see **chapter 9.06 Selecting a program number**.



Seam zone

Displays the number of seam zones in the sewing program.



Input mode

Quit the sewing mode and call up input mode.



Stitch lengths

Opens the menu for entering the feed motion of the roller presser and feed wheel, see **chapter 9.07 Adjusting stitch lengths**.



Start backtack

Opens the menu for entering the seam start, see **chapter 9.08 Entering start and end backtacks**.



End backtack

Opens the menu for entering the seam end, see **chapter 9.08 Entering start and end backtacks**.



Needle raised

Positions the needle in the top position (thread lever t.d.c.)



Backtack suppression

When pressed once, the next bartack is suppressed.

When pressed twice, the next two bartacks are suppressed.



Needle position raised

If this function is on, the needle moves to the top position when sewing stops (thread lever t.d.c.)

Thread trimming



When the function is activated, thread trimming with the pedal function is possible.

Roller presser up



When this function is activated, the roller presser is raised after sewing stops.

Roller presser down after thread trimming



When this function is activated, the roller presser is not raised after thread trimming.

Regulated thread tension with touch



By pressing the arrow keys for the thread tension (compare pictures: manual sewing, fixed program 1 and fixed program 2) the thread tension is changed directly. The setting range is between 0 and 100. In addition to the numerical value, the set value is represented by a bar display.

- Sewing is performed using the pedal and knee switch functions, see **chapter 7.04 Pedal** or **7.07 Knee switch**.

10.03 Program interruption

If the course of a seam program is interrupted (e.g. a broken thread), the program interrupt function must be called up.



- The seam program course is interrupted after pressing the **program interrupt** key. Sewing can continue manually and the values for the stitch length from the current seam program are taken over.

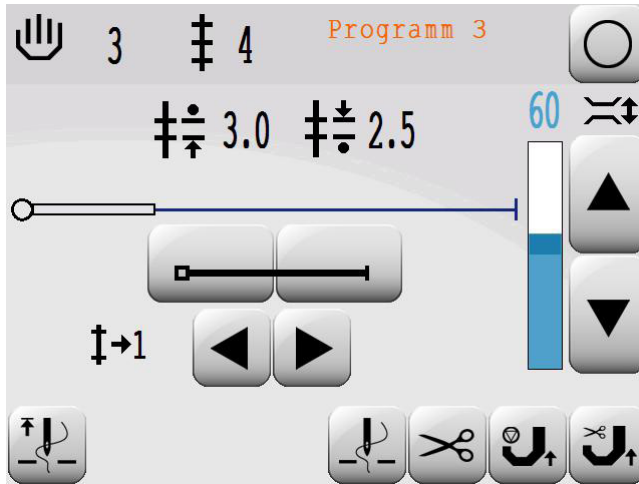

- The corresponding **key** can be used to select the seam zone, in which the seam program should be continued.
- Or sequence the program forwards and backwards.



- Or call up manual sewing

10.04 Error messages

If an error occurs, the text "ERROR" appears on the display, together with an error code. An error message is generated by incorrect settings, faulty elements or seam programs, as well as overloading.



- Correct the error.
- Acknowledge the elimination of the error.



For a description of errors see chapter **11.08 Error codes and descriptions**.

11 Input

The Parameter input, Info, Create/correct sewing program, Teach-in, Program management and Service functions are available in input mode.

- Switch the machine on.

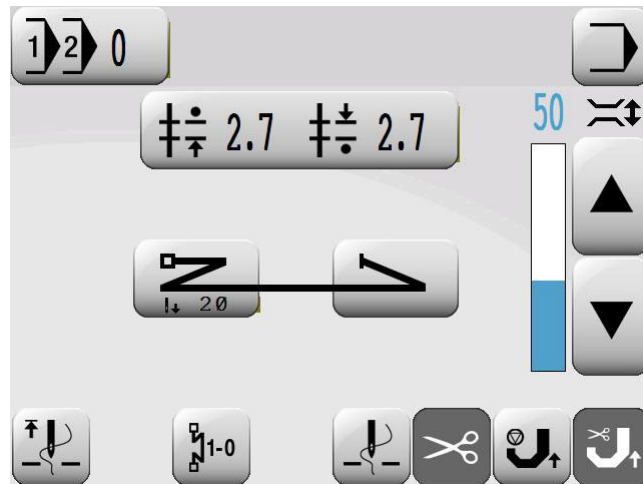

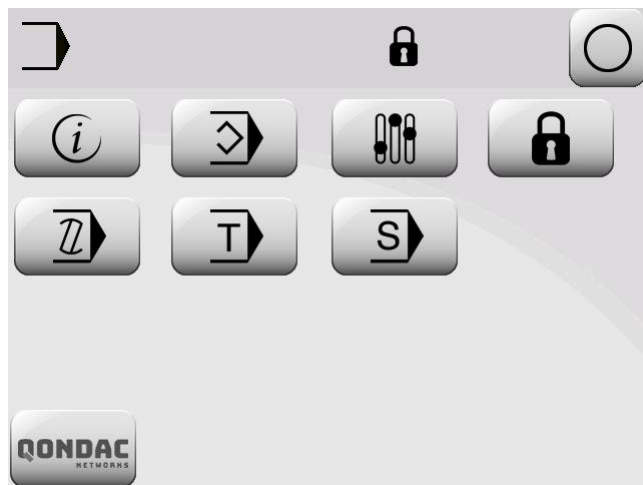

- Call up input mode.



Description of the functions

-  **Sewing mode**
Quit input mode and call up sewing mode.

-  **Software information**
Calls up information about the current machine software.

-  **Program management**
Opens the menu for managing seam programs, see **chapter 11.03 Managing seam programs**.

-  **Parameter selection**
Change the value of the selected parameter, see **chapter 11.04.02 Example of a parameter input**.



Access rights

Some functions and function groups are only released for execution after entering an access code. The release remains active until the machine is switched off. The access rights for the individual functions and function groups can be changed in the function group **8100**. The access code for code-protected functions can also be changed (factory setting: **1500**).



Create/correct program

Opens the menu for entering or changing seam programs, see **chapter 11.01 Seam program input via the “Create/correct program” function**.



Teach-in

Opens the menu for entering seam programs by stitching a sewing sample, see **chapter 11.02 Seam program input via the “Teach-in” function**.



Service

Opens the service menu, see **the service menu chapter 11.05**

11.01 Seam program input via the “Create/correct program” function

This function is used to enter the seam program by entering or changing the corresponding values on the control panel. This type of seam program input is particularly suitable for correcting already existing seam programs.

The programming examples shown in the display are only as follows, when no seam program has been entered under the selected program number.

11.01.01 Examples of seam program input using the “Create/correct program” function

The seam to be programmed should

- contain 3 seam zones
- and be saved under program number **10**

- Switch the machine on.

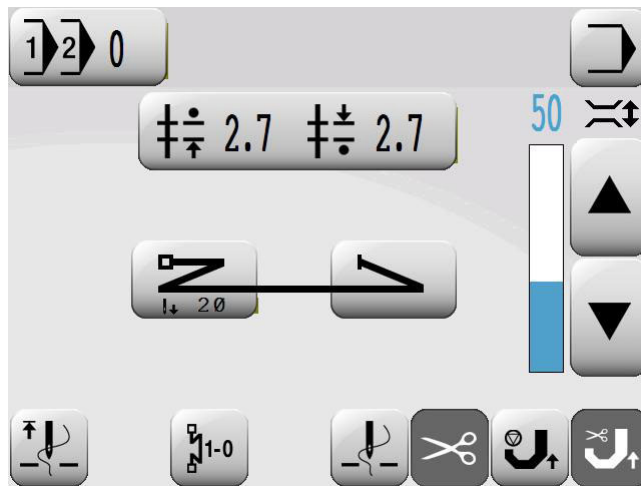

- Call up input mode.

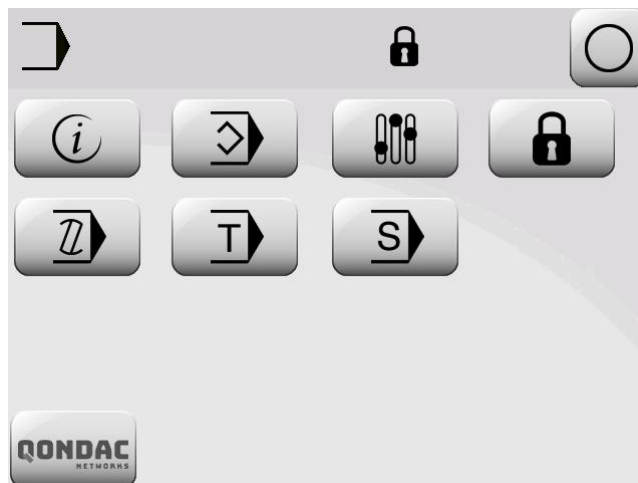

- Call up the “Create/correct seam program” function.

- Enter the template code, see chapter **9.10 Entering/changing the template code**.



- Adopt the code number entered.



- Select the desired program number or enter it via the keypad.
- Select a program number from 3 - 99, see **chapter 9.06 Selecting a program number**.



- Confirm selection

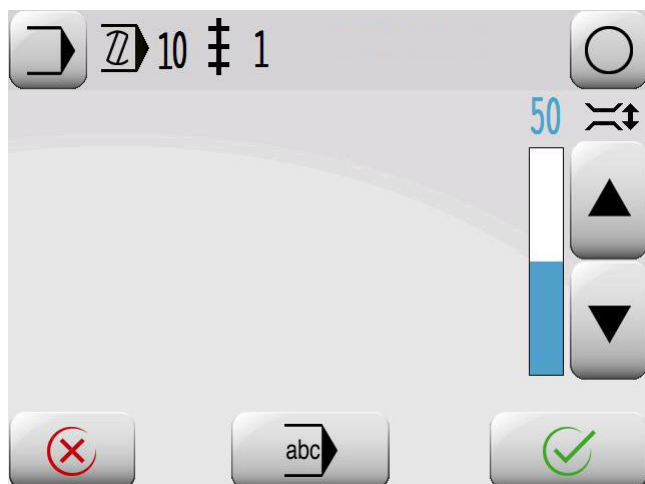

- Call up the comment input menu.

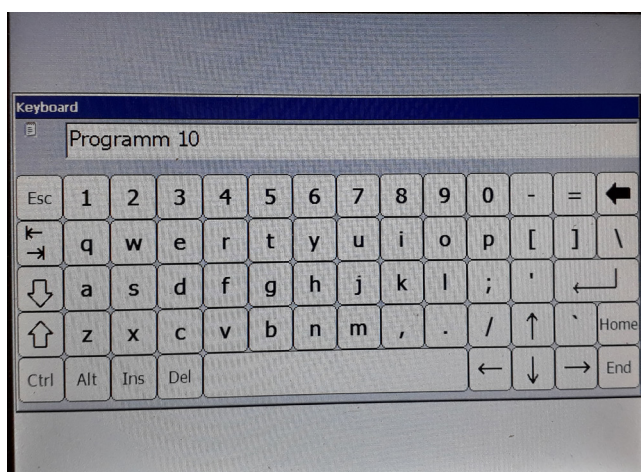

- Enter a comment via the keypad and numeric keypad.

- Conclude the comment input.

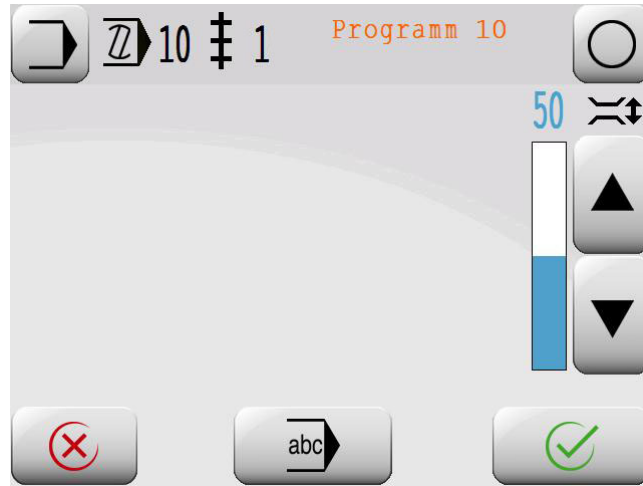

- eventually change the thread tension

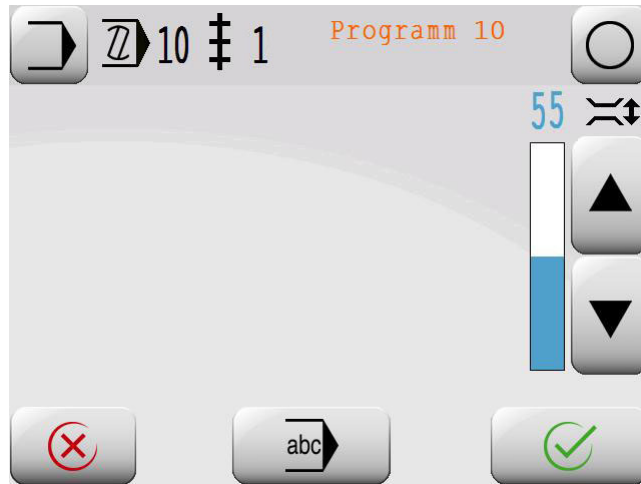

- Confirm selection

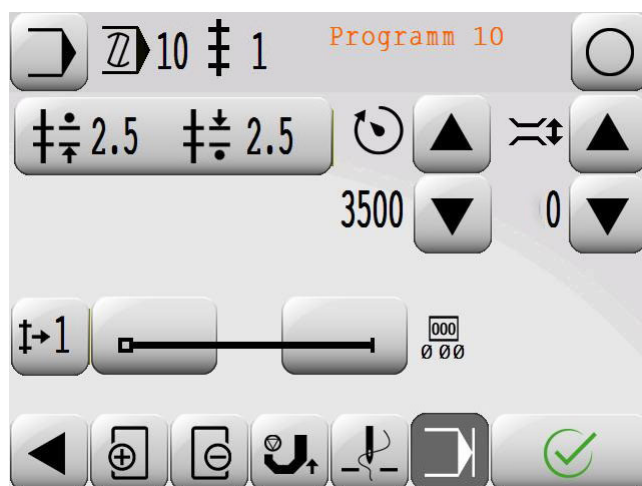

The first seam area should

- a maximum speed of 2000 min¹
- one stitch length (for roller foot and push wheel) of 2.6 mm
- a double starting bar (2 stitches forwards and backwards)
- a bolt speed 500 min¹
- and stitch count (10 stitches) included

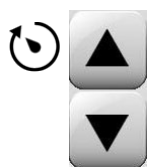

- Enter maximum speed, for example, 2,000 min¹



- Click stitch length, e.g. Enter 2.6 mm



- End input



- Call up the menu for entering the start bar.



- Enter number of stitches for forward and backward stitches (for example 2 stitches)

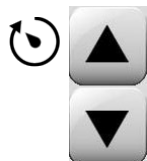

- Enter the bolt speed, for example, 500 min¹



- End input



- Click the End Bolt button



- Enter stitch count (10 stitches)



- Click Stop button



- Click the scroll foot up button

- End input
- Open program end

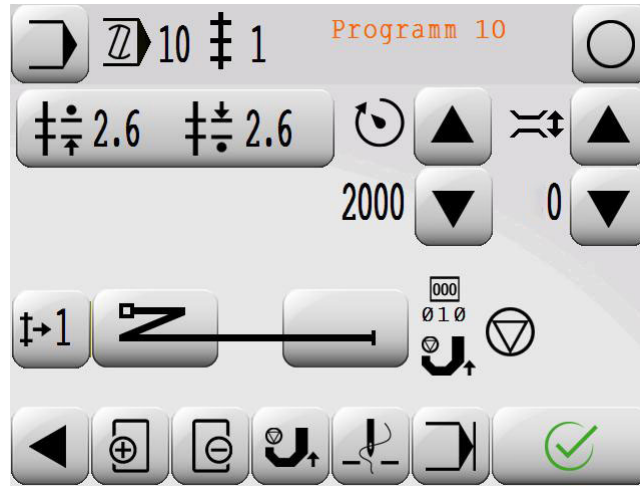

- Enter

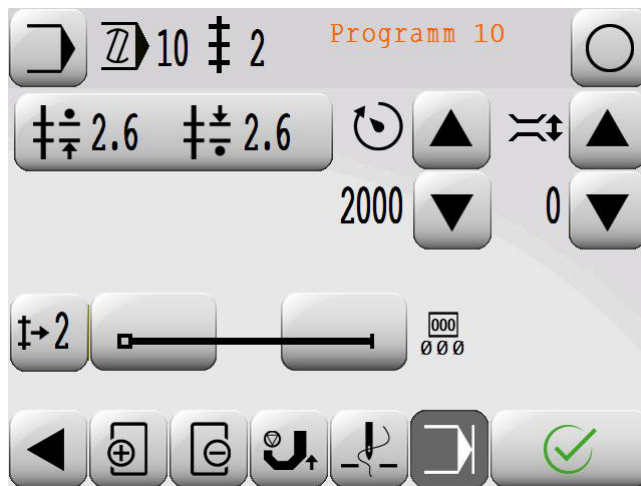

The second seam area should
 - stitch count (10 stitches) included

- Click the end bolt button
- Enter stitch count (5 stitches)
- Click stop button
- Click the scroll foot up button
- End input

- Open program end

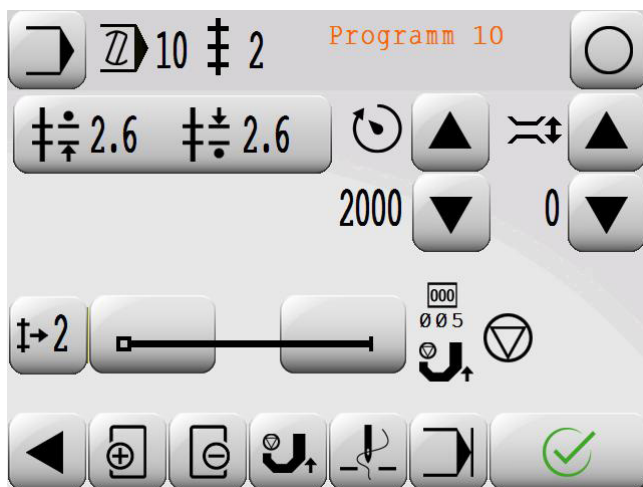

- Enter

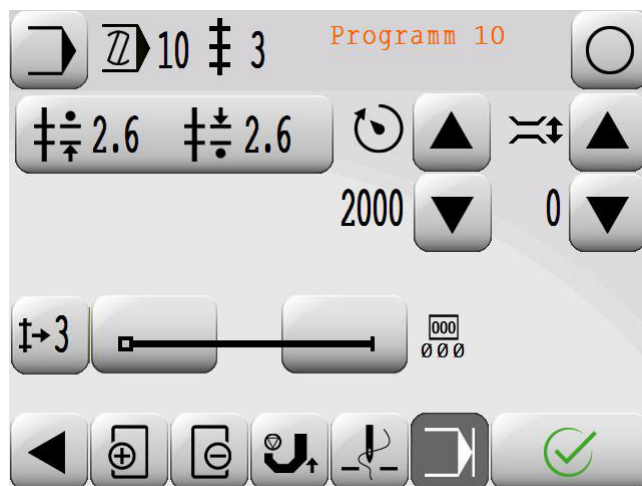

The third seam area should

- stitch count (10 stitches) included



- Click the end bolt button



- Enter stitch count (10 stitches)



- Click the thread trimming button



- Click the scroll foot up button



- Click on the double end latch button



- Enter number of stitches for forward and backward stitches (for example 2 stitches)

- Enter the bolt speed, for example, 500 min⁻¹
- End input

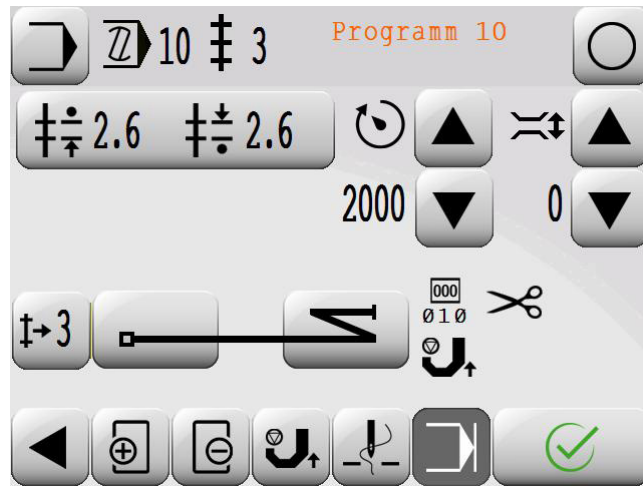

- Enter

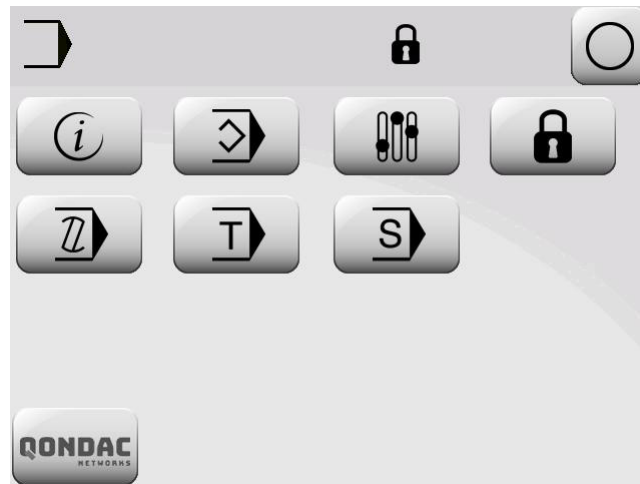

- End input

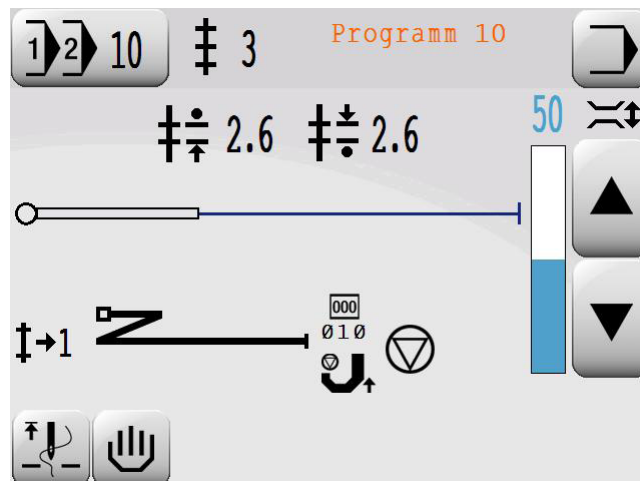

- Start seam program 10

11.02 Seam program input via the “Teach-in” function

This function is used to create the seam program by stitching a sewing pattern. A new creation is always made, meaning that when selecting an already existing program it is overwritten.

11.02.01 Example for seam program input via the “Teach-in” function

The seam program should

- contain 3 seam zones
- and be saved under program number **10**

- Switch the machine on.

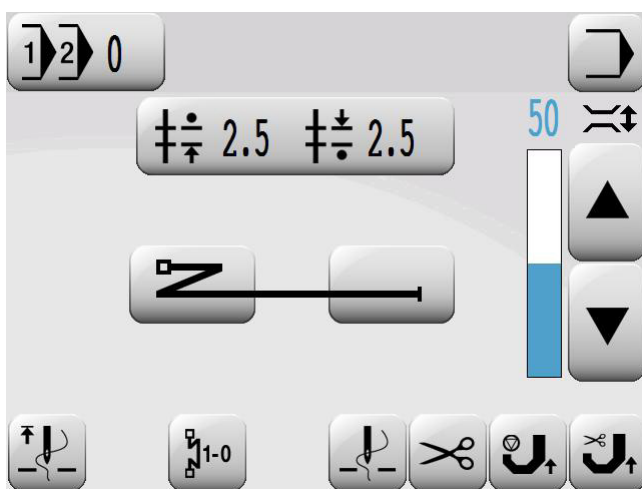

- Call up input mode.

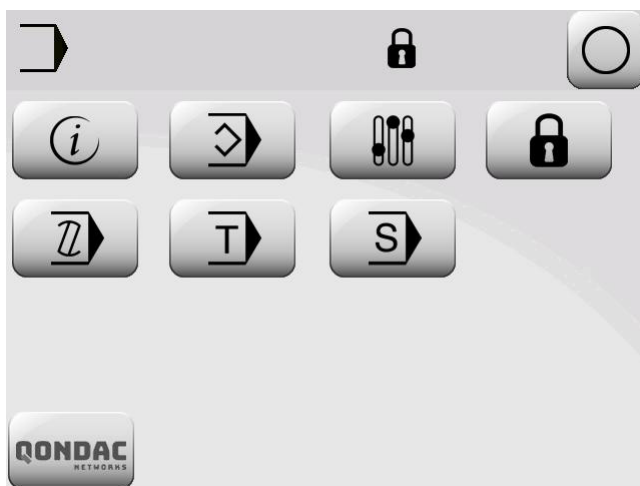

- Call up the “Teach-in” function.

- Enter the template code, see chapter **9.10 Entering/changing the template code**.



- Adopt the code number entered.

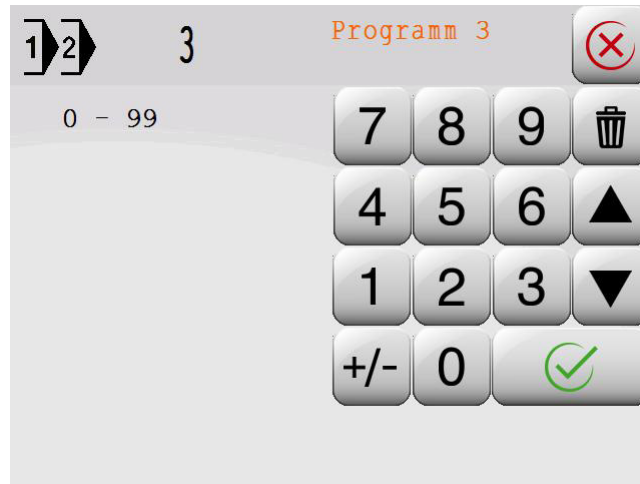

- Select the desired program number or enter it via the keypad.
- Select a program number from 3 - 99, see **chapter 9.06 Selecting a program number**.



- Confirm selection

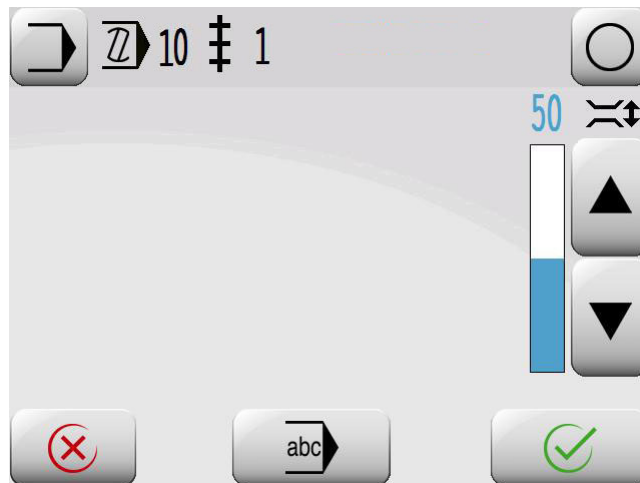

- Call up the comment input menu.

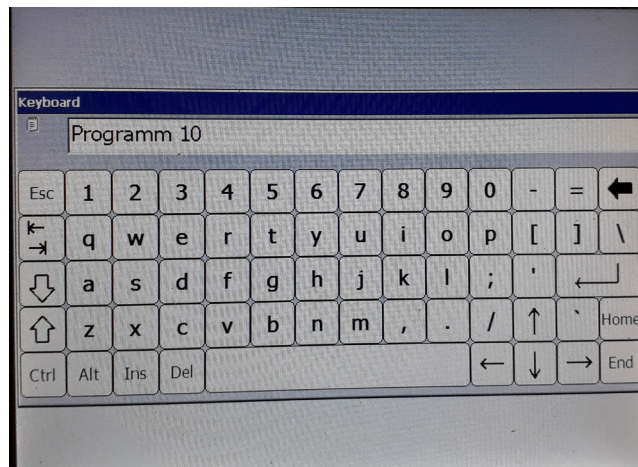

- Enter a comment via the keypad and numeric keypad.



- Conclude the comment input.

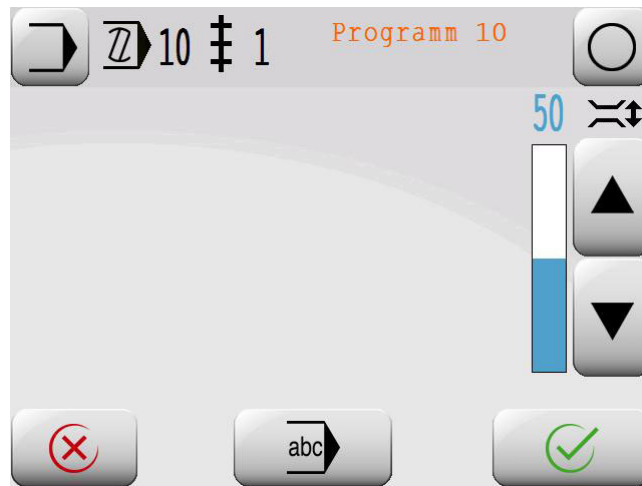

- eventually change the thread tension

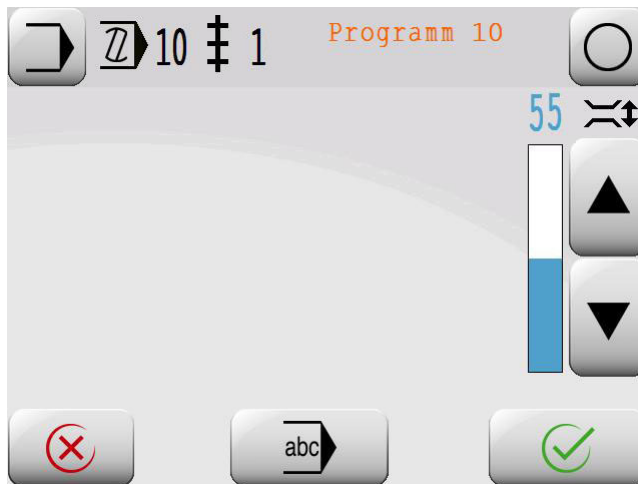

- Confirm selection

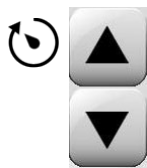
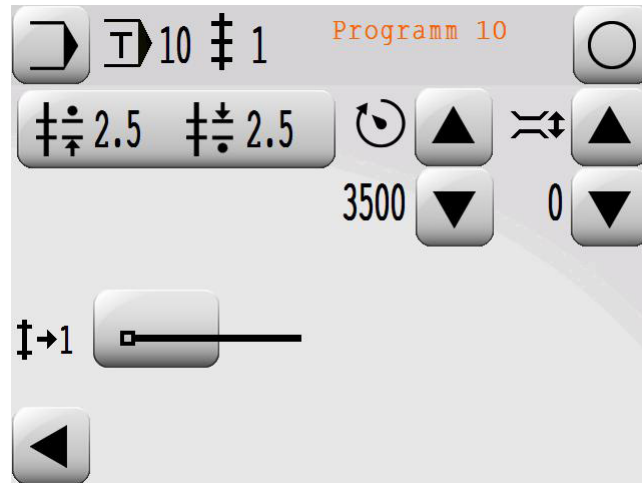

● Enter maximum speed, for example, 2100 min1

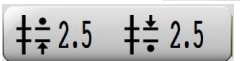

● Click stitch length, e.g. Enter 2.6 mm



● End input



● Click on the start bar key



● Call up the menu for entering the start bar.



● Enter number of stitches for forward and backward stitches (for example 2 stitches)

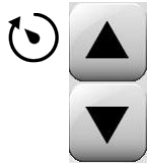

● Enter the bolt speed, for example, 600 min1



● End input

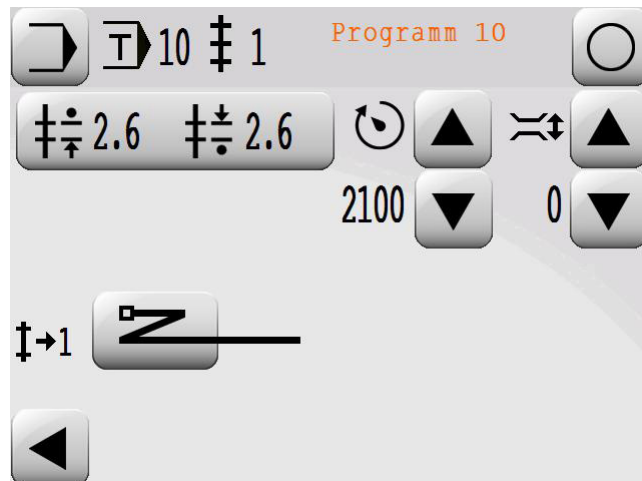

Number of stitches to learn about sewing

After sewing, the following information and functions appear on the display:

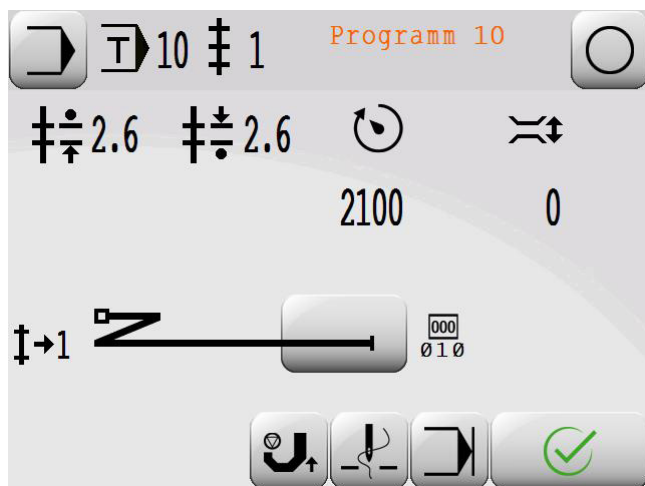

● Click the end bolt button



● Click stop button



● Click the scroll foot up button



● End input

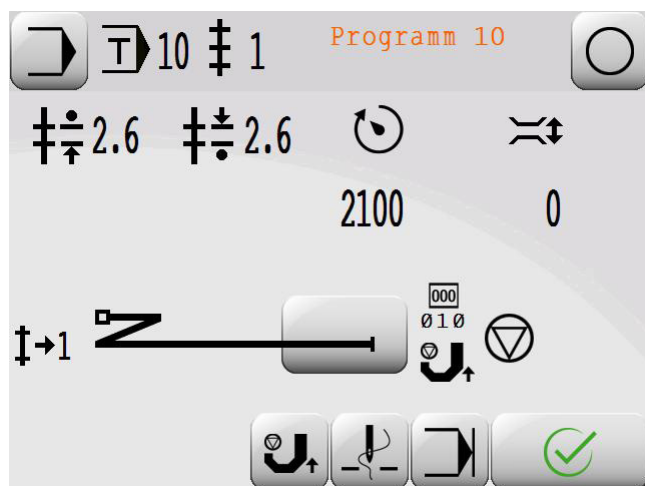

● Enter

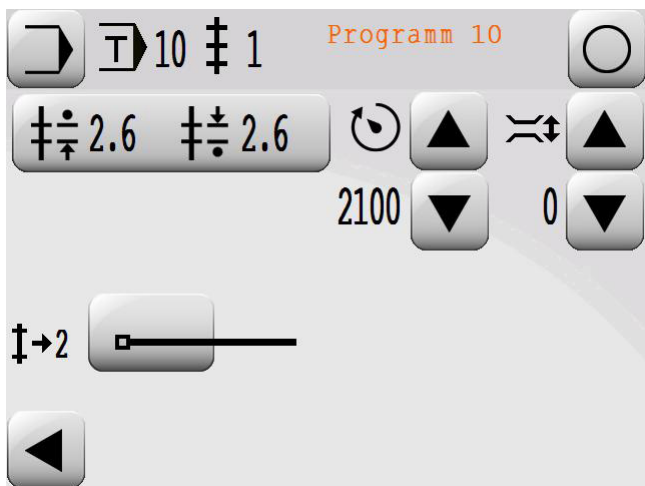

Number of stitches to learn about sewing

After sewing, the following information and functions appear on the display

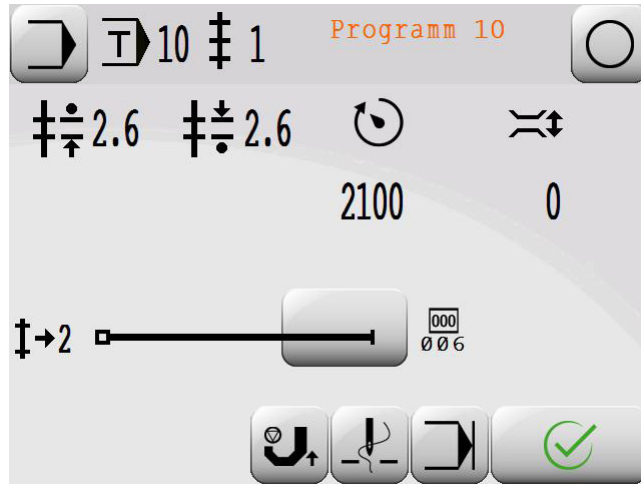

● Click the end bolt button



● Click stop button



● Click the scroll foot up button



● End input

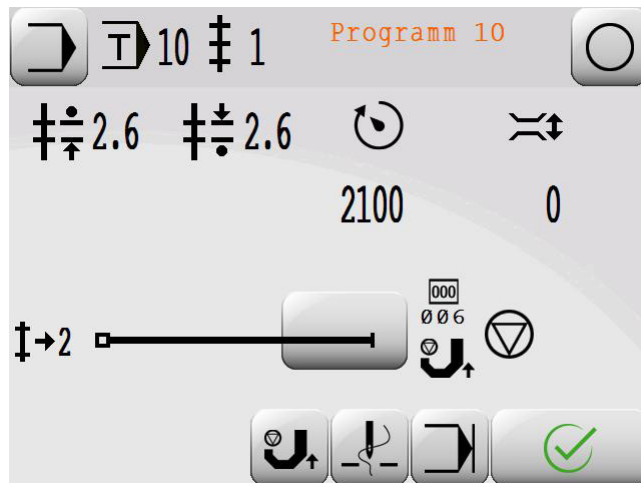

● Enter

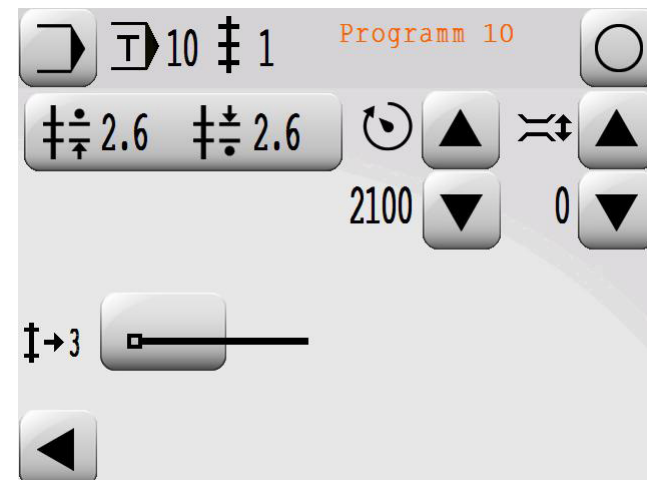

Number of stitches to learn about sewing

After sewing, the following information and functions appear on the display

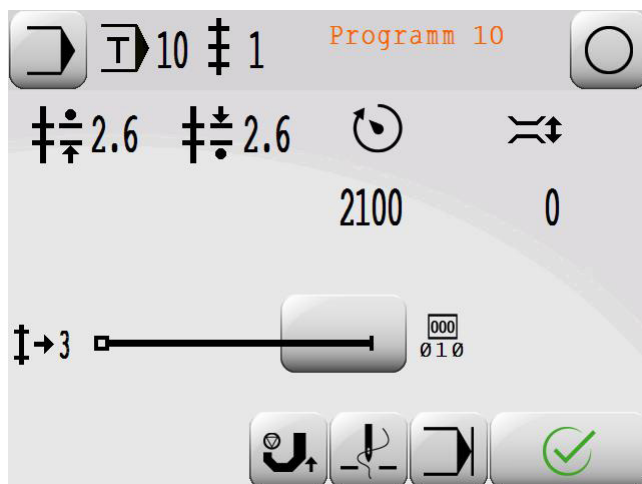

- Click the end bolt button



- Click the thread trimming button



- Click the scroll foot up button



- Click on the double end latch button



- Enter number of stitches for forward and backward stitches (for example 2 stitches)



- End input



- Close program end

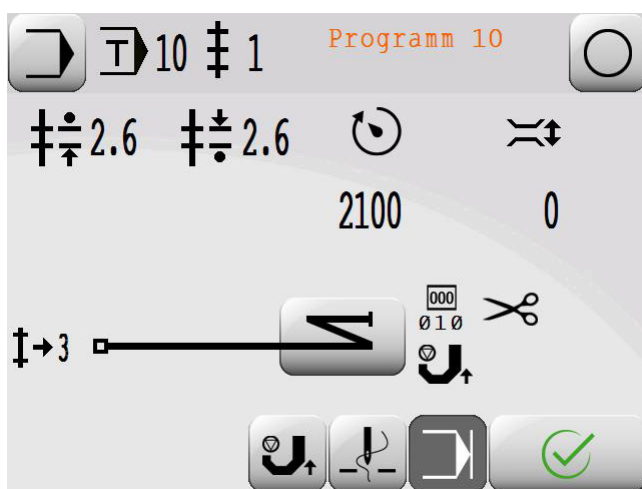

- Enter



- End input
- Start seam program 10

11.03 Managing seam programs

The program management displays the contents of the machine memory in the left-hand half of the screen and the SD card in the right-hand half of the screen, and is used to erase and copy programs. The selected programs are displayed in red. The machine data can be saved on the SD card or loaded from the SD card if the MDAT function is activated. The format function is used to format the SD card. The individual operations are displayed in English in a dialogue box. After inserting the SD card, it will take up to **20 s** until the SD card is recognised as inserted.

- Switch the machine on.



- Call up input mode.



- Call up program management.
SD card and machine memory are re-read.

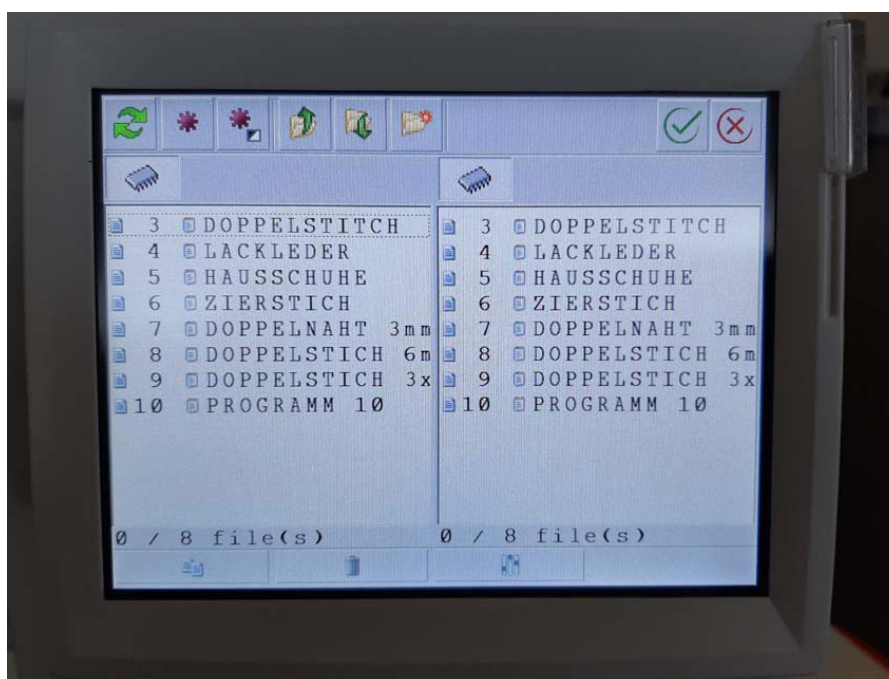

Description of the functions



Rewrite directory



To mark



Reverse the marking











Directory up



Directory down



New directory. No subdirectories can be created in the machine memory.

	Select program if the current directory is the directory of the machine
	end
	Key memory of the machine
	SD card key (If directory P15XX_1 is not available, it will be created automatically)
	Button network
	Copy
	Delete
	Display programs / machine data

Dialogue box

The dialogue box is used to communicate the current operation. If necessary, additional keys are shown for answering questions.

Enter	Enter key Approval for a program.
All	All key Approval for one or all marked programs.
Esc	Esc key Reject for one or all marked programs.
Next	Next key Reject a program.
MDAT	Select machine data After pressing MDAT, the machine data can be copied or deleted on the SD card.
Format	Format the SD card The SD card is formatted after pressing FORMAT. A prompt for confirmation is displayed before the SD card is formatted. The card is completely formatted if it cannot be read. All programs and machine data in this directory are deleted if they can be read and the directory \P1591 for the 1591 exists. If the directory \P1591 for the 1591 does not exist, only the directory is created. This is to ensure that programs from other machines and other files are not lost.

11.04 Parameter settings

11.04.01 Overview of parameter functions

After switching the machine on, the input mode is called, in which the individual parameters can be directly called by pressing the desired function. All parameter groups or also individual ones can be protected by a code against unauthorised access.

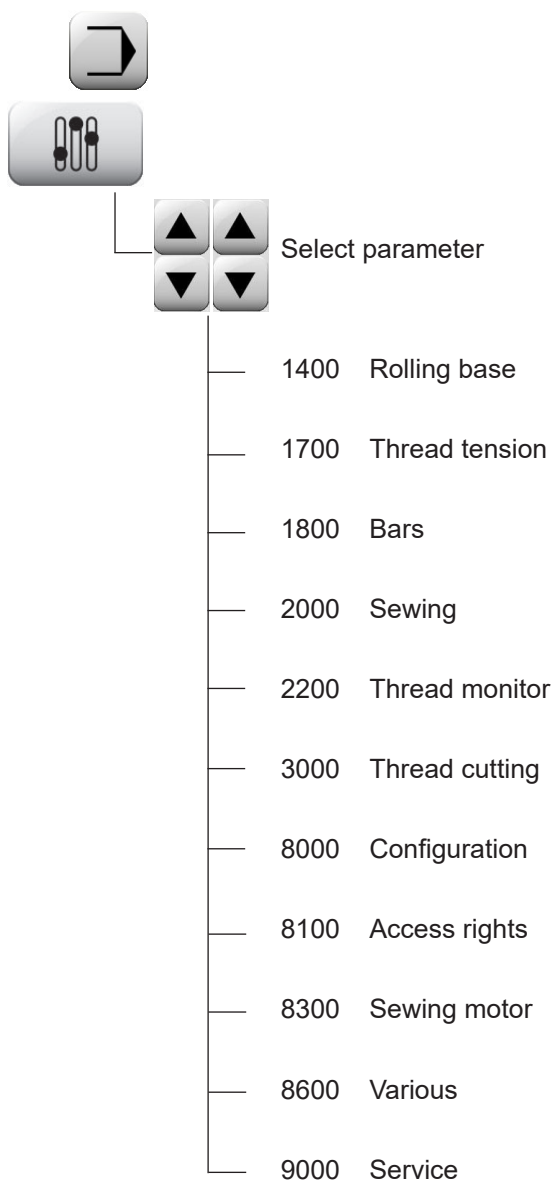

11.04.02 Example of a parameter entry

- Switch the machine on.

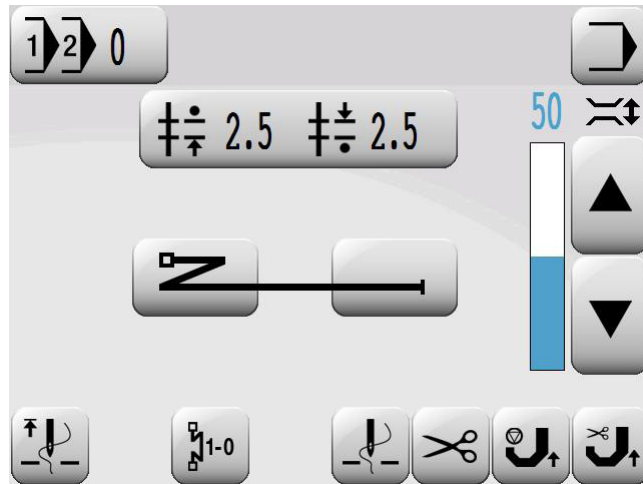

- Call up input mode

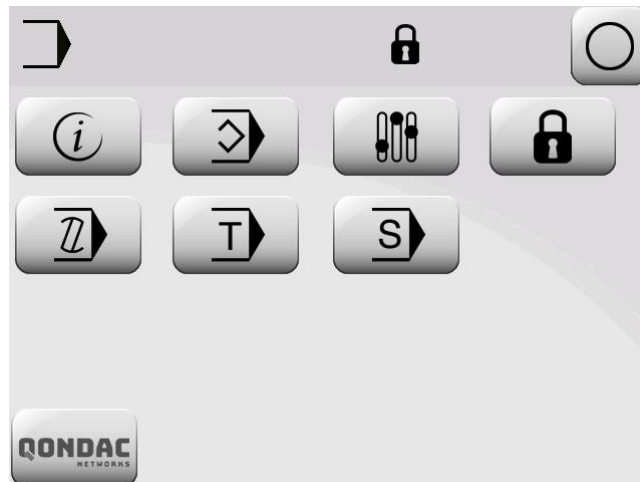

- Call parameter input.

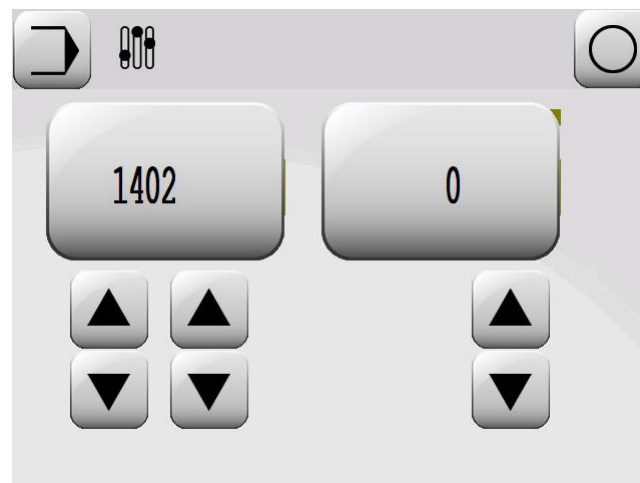

- For example, call up parameter "2201"

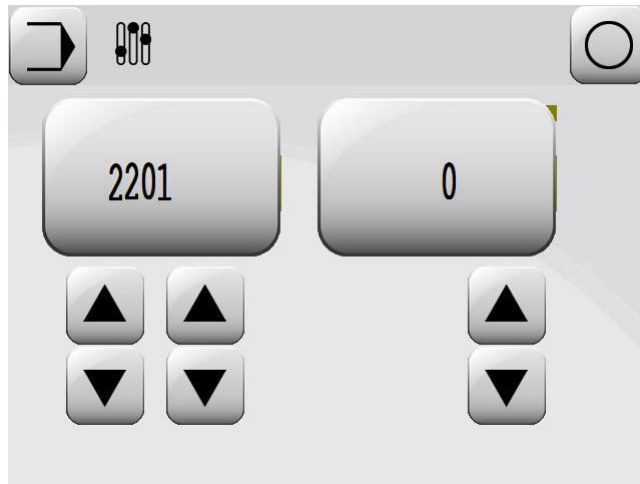

- If necessary, Enter the code number, see **chapter 9.10 Entering / changing the code number**.



- For example, set value 1.

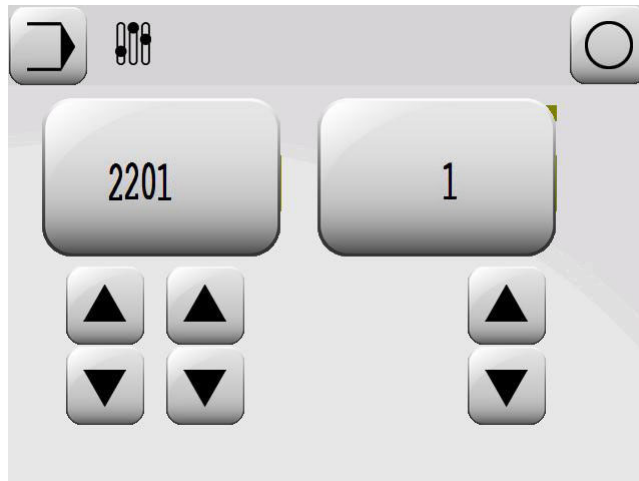

- Conclude the input.

11.04.03 Parameter list for control **P430SD**

Group	Parameter	Description	Setting range	Set value 1571; 1591;1593
1400	1402	Roller presser lowering speed 0 = slow, 1 = quick	0 - 1	0
	1460	Holdoff time roller presser lift	0,001s - 1,500s	0,050s
	1461	Lower start delay after roller presser	0,001s - 1,500s	0,050s
	1462	Set roller presser lift Must be increased for high foot pressure	0,001s - 0,200s	0,080s
	1480	Roller presser magnet pulse	10% -50%	35%
1700	1703	Open thread tension on stop and roller presser lift 0 = OFF, 1 = ON	0 - 1	1
	1704	Open thread tension after trimming and roller presser lift 0 = OFF, 1 = ON	0 - 1	1
	1720	Thread tension ventilation position	0° - 359°	300°(1571) 300°(1591) 290°(1593)
	1760	Time thread tension ventilation before timing	0,001s - 1,500s	0,100s
	1780	Thread tension magnet timing	10% -50%	35%
2000	2010	Stitch length at the touch of a button (parameter stitch)	0,8 - 7,0mm	4,0mm
	2011	Soft starting stitches	0 - 15	0
	2040	Soft start speed	100 - 3500	1500
	2041	Minimum speed	100 - 300	180
	2042	Maximum speed	100 - 3500	3500
2200	2201	Bobbin thread monitor (0 = OFF, 1 = Counter)	0 - 1	0
	2210	Bobbin thread counter	0 - 99999	12000
3000	3003	Reverse rotation , 0 = OFF, 1 = ON	0 - 1	1
	3020	Thread trimmer magnet position on	0° - 359°	48°(1571) 48°(1591) 66°(1593)
	3021	Thread trimmer magnet position timing	0° - 359°	283°(1571) 283°(1591) 235°(1593)
	3022	Thread trimmer magnet position off	0° - 359°	339°(1571) 339°(1591) 348°(1593)
	3026	Reverse rotation position	0° - 359°	283°(1571) 283°(1591) 340°(1593)
	3040	Cutting speed	100 - 300	180
	3060	Waiting time before turning back	0,001s - 1,500s	0,020s
	3080	Thread trimmer magnet timing	10% -50%	35%
	8000	8002	Take-up lever at t.d.c. position	0° - 359°
8003		Position of needle at t.d.c. bottom position	0° - 359°	48°(1571) 48°(1591) 66°(1593)
8004		Machine configuration	1 - 9	1(1571) 1(1591) 9(1593)

Group	Parameter	Description	Setting range	Set value 1571; 1591; 1593
8000	8005	Single stitch key assignment 1 = half stitch 2 = single stitch 3 = double stitch 4 = parameter stitch (parameter 2010) 5 = needle up 6 = Target stitch in sewing at 1574 7 = Not high 8 = knee switch	1 - 8	2
	8006	Half stitch key assignment 1 = half stitch 2 = single stitch 3 = double stitch 4 = parameter stitch (parameter 2010) 5 = needle up 6 = Target stitch in sewing at 1574 7 = Not high 8 = knee switch	1 - 8	1
	8025	Adjust sewing motor on sewing head (Needle top edge stitch plate)		23°±6°(1571) 23°±6°(1591) 31°±6°(1593)
8100	8101	Access rights for function group 100* (Info)	0 - 1	0
	8104	Programming access rights*	0 - 1	1
	8114	Access rights for function group 1400*(Roller presser)	0 - 1	1
	8115	Access rights for function group 1500* (Placed stitch)	0 - 1	1
	8117	Access rights for function group 1700* (Thread tension)	0 - 1	1
	8118	Access rights for function group 1800* (Backtack)	0 - 1	1
	8120	Access rights for function group 2000* (Sewing)	0 - 1	1
	8122	Access rights for function group 2200* (Thread monitor)	0 - 1	1
	8130	Access rights for function group 3000* (Thread trimming)	0 - 1	1
	8180	Access rights for function group 8000* (Configuration)	0 - 1	1
	8181	Access rights for function group 8100* (Access rights)	0 - 1	1
	8183	Access rights for function group 8300* (Sewing motor)	0 - 1	1
	8186	Access rights for function group 8600* (Others)	0 - 1	0
	8187	Access rights for function group 8700* (QONDAC)	0 - 1	1
8190	Access rights for function group 9000* (Service)	0 - 1	1	
	8199	Input access code	0 - 9999	1500
8300	8301	P-section speed regulator	3 - 200	80
	8302	I-section speed regulator	0 - 200	80
	8303	P-section position controller	1 - 50	20
	8304	D-section position controller	1 - 100	30

Group	Parameter	Description	Setting range	Set value 1571; 1591;1593
8300	8305	Time for position controller	0,000s - 2,000s	0,250s
	8306	P-section position controller for remainder brake	0 - 50	25
	8307	Maximum torque for remainder brake	0 - 50	0
	8308	Acceleration ramp	1 - 50	35
	8310	Braking ramp	1 - 50	35
	8311	Positioning speed	60 - 300	180
	8312	Dead man time	0,000s - 0,250s	0,150s
	8314	Positioning technique	1 - 2	1
	8316	Motor starting current	7 - 15	12
	8317	Pilot during acceleration	0 - 100	0
	8318	Input taxes when decelerating	0 - 100	0
8600	8601	Control panel key tone 0 = OFF, 1 = ON	0 - 1	1
	8602	Key tone when switching over between zones 0 = OFF, 1 = ON	0 - 1	0

11.05 Error messages and description

Error	Description
E 001	System error
E 002	Sewing motor E002/BB/xxx BB = 20: Deadman 01: Switch on speed 02: Positioning 03: Start distance 04: Read distance 05: Set translation 06: Read translation 07: Error reset 08 Write parameters 09: Read version 0A: Read speed 0B: Read actual position 0C: Delete distance xxx = Sewing motor controller error byte (see motor error)
E 003	Seam zone data
E 004	Flash memory
E 005	No room on the heap
E 006	Mains voltage outside the work area
E 007	24V IO power supply E007/xx xx= 1: Short circuit 2: overload 3: 5V timeout when switching on 4: 20 V timeout when switching on
E 008	60V SM power supply E008/xx xx= 1: Short circuit 2: overload 3: 20V timeout when switching on 4: 50 V timeout when switching on 5: 60 V not reached after switching on
E 009	Encoder of the sewing drive not plugged in
E 017	Serial interface E017/xx xx= 4: dead man expired 5: Number of communication attempts exceeded 6: Lost USB connection
E 019	Sewing motor has no 180 ° track
E 020	CAN interface E020/xx xx= 1: Number of CAN nodes wrong 2: Hardware error (possibly short circuit) 3: Communication
E 021	Button pressed when switching on
E 022	Pedal activated when machine turned on

Error	Description
E 040	Stepper motor 1 E040/xx xx= 1: Wrong command 2: Overtemperature 3: Excess current
E 041	Stepper motor 2 E041/xx xx= 1: Wrong command 2: Overtemperature 3: Excess current
E 042	Stepper motor 3 E042/xx xx= 1: Wrong command 2: Overtemperature 3: Excess current
E 101	Program number invalid (3 - 99)
E 102	Error in the sewing program
E 106	Incorrect stitch length
E 107	Ramp not completed
E 110	Needle drive mid-point not found
E 111	Sewing displacement error
E 125	Fatal, unrecoverable internal error
E 300	Error in program E300 / xx xx= 9: Program not available 13: Error in the program
E 301	Error with Commander E301 / xx xx= 1: Directory full 2: Directory could not be created 3: directory name 4: List of machine data must not be deleted 5: Machine data can not be deleted 6: Directory can not be deleted (not empty?) 7: File can not be deleted Files can not be deleted 9: Current directory can not be deleted 10: Marked files can not be deleted 11: not empty directory can not be deleted 12: Directory can not be copied 13: File can not be copied 14: File can not be overwritten 15: Directory can not be overridden 16: File can not be copied to itself: 17: Marked files can not be copied 18: Empty file 19: The directory of the machine data must not be copied 20: read-only

Error	Description
E 317	Interface to the controller E317 / xx xx = 1: buffer overflow 2: Receive ring buffer overflow 3: Sender input buffer overflow 11: Send 12: receiving 42: Checksum wrong 45: Timeout 45: Interface protocol 46: Timeout when sending the machine data

11.06 Sewing motor errors

Error	Description
48	Timeout for increasing speed
49	Timeout from deadman
50	Timeout for initialisation
51	Number of communication attempts exceeded
52	Timeout during communication
53	Invalid command
54	Checksum wrong
55	Invalid data
56	Parameter does not exist
57	Parameter limits exceeded or exceeded
58	Sewing motor has not turned yet
70	Motor blocked
71	External synchronization mark not found
72	Excess current (20A)
73	Sewing motor not plugged
74	Synchronization mark at the first attempt not found
75	Current sensors out of tolerance
76	Deadman expired
77	Error at brake resistor
78	Overvoltage
79	Undervoltage
80	Fatal, unrecoverable internal error
81	Synchronization mark of the sewing motor is missing
82	No valid hardware identifier
83	Ground fault of the sewing motor detected

11.07 Warning messages

Error	Description
Warning 2	Bobbin thread error

12 Maintenance and Care

12.01 Maintenance intervals

Cleaning.....	daily, several times if in continuous operation
Clean the hook area.....	daily, several times if in continuous operation
General oiling	daily, before start-up
Oil the hook	daily, before start-up
Oil level (thread lubrication / hook lubrication)	twice a week
Lubricate the bevel gears.....	once as year



These maintenance intervals are based on an average running time of a single shift production shop. Shorter maintenance intervals are recommended for increased running times.

12.02 Cleaning the machine

The required cleaning cycle for the machine depends on the following factors:

- Single or multi-shift operation
- Dust formation caused by the workpieces

Optimal cleaning instructions can therefore only be defined on a case-by-case basis.

Clean the hook, hook area and gear wheel **4** daily or more often during continuous operation.



Disconnect the machine from the electricity mains for all cleaning work by shutting off the main switch or removing the mains plug! Risk of injury due to accidental machine start-up!

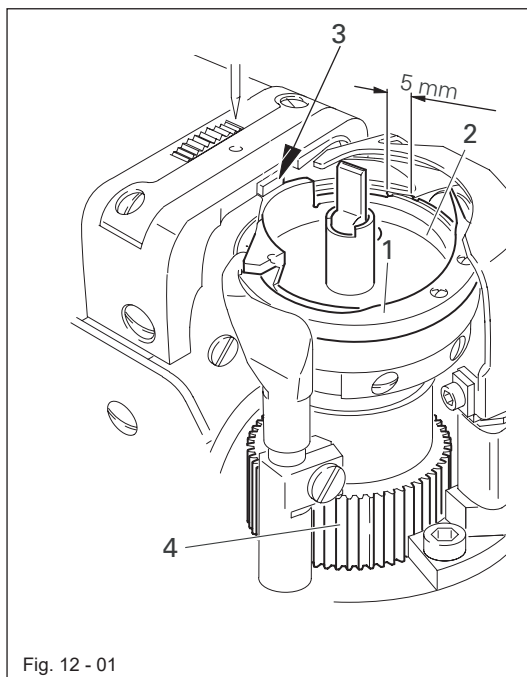

Fig. 12 - 01

The following tasks are recommended during a single shift operation to avoid operational errors:

Clean the hook area

- Clean the hook area with a brush

Clean the hook

- Move the needle bar to the top position.
- Open the post cover.
- Remove the bobbin case sewing head with bobbin.
- Unscrew the hook gib **1**.
- Turn the handwheel until the tip of the lower bobbin **2** has penetrated approx. **5 mm** into the groove of the hook race.
- Remove the lower bobbin **2**.
- Clean the hook race with kerosene.

- Make sure that the horn **3** of the lower bobbin **2** engages in the groove of the needle plate when inserting the lower bobbin **2**.
- Screw on the hook gib **1**.
- Insert the bobbin case with the bobbin and close the post cap.



Do not operate the machine with an open post cap!
Risk of injury from the rotating hook!

12.03 Oiling the hook

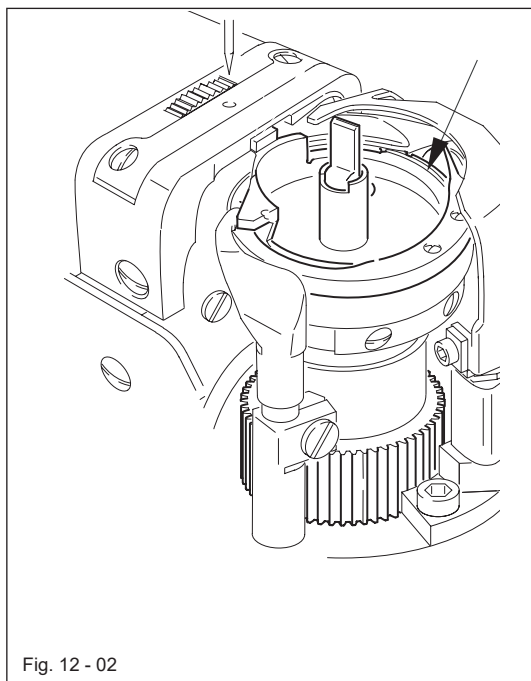

Switch off the machine!
Risk of injury due to accidental machine start-up!

- In addition, add a few drops of oil onto the hook race at the initial start-up or if the machine has been standing still for a prolonged period of time (see arrow).



Only use oil with a centre viscosity of **22.0 mm²/s** at **40 °C** and a density of **0.865 g/cm³** at **15 °C**!

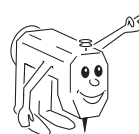

We recommend
PFAFF sewing machine oil
Order no. **280-1-120 144**.

12.04 Checking the oil level of the hook and front parts

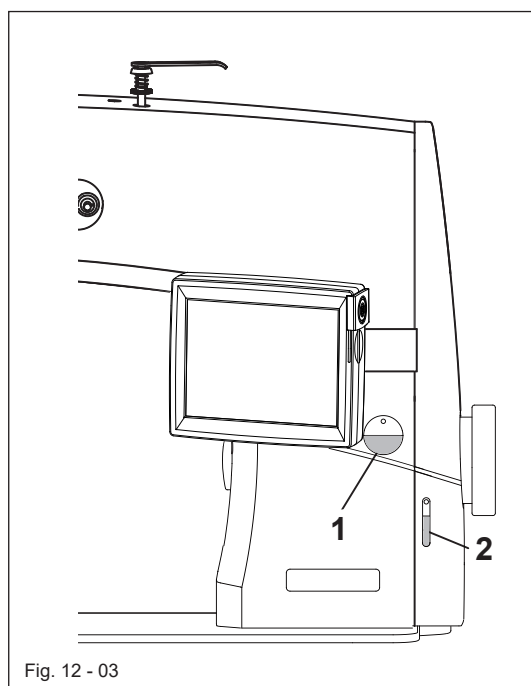

Check the oil level before every start-up.
Oil must always be visible in the sight glasses **1** and **2**

- Add oil through the respective hole above the sight glasses as needed.



Only use oil with a centre viscosity of **22.0 mm²/s** at **40 °C** and a density of **0.865 g/cm³** at **15 °C**!

We recommend PFAFF sewing machine oil, order no. **280-1-120 144**.

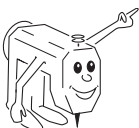

12.05 Lubricating the bevel gears

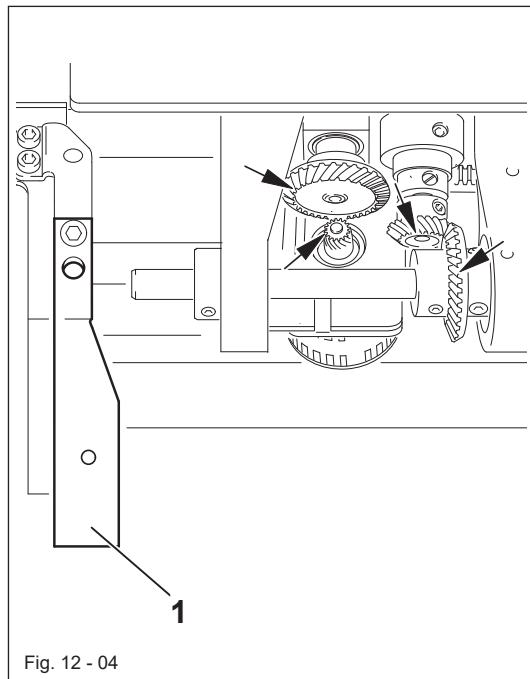

Fig. 12 - 04



Switch off the machine!

Risk of injury due to accidental machine start-up!

- Fresh grease should be applied to all bevel gears once a year.
- Tilt back the machine sewing head and let it rest on the sewing head support.
- To return the machine sewing head to its upright position, press the anti-tipping device **1** backwards and return the machine sewing head to its upright position using both hands!

Return the machine sewing head to its upright position using both hands!



Risk of injury from crushing between the machine sewing head and the table top!

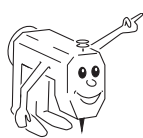

We recommend

PFAFF sodium soap grease with a dripping point of approx. **150°C**.

Order no.: **280-1-120 243**.

12.06 Topping up the thread lubrication oil reservoir

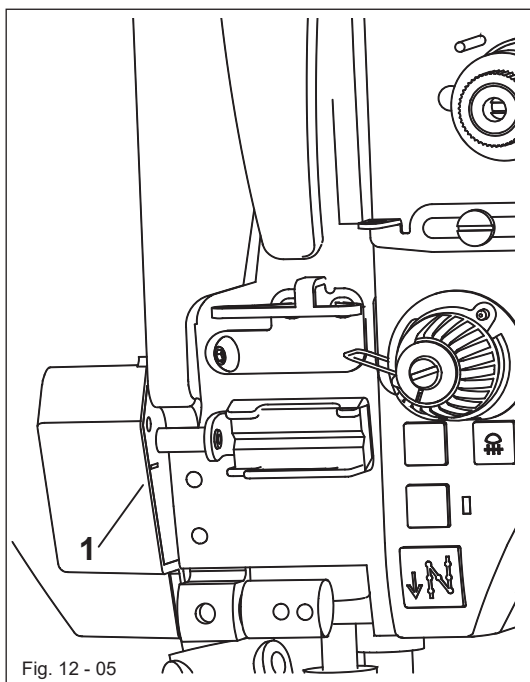

Fig. 12 - 05



Check the oil level before every start-up.

The oil reservoir **1** must always have oil in it.

- Add oil through hole as needed

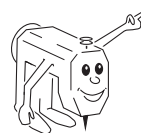

We recommend

PFAFF thread lubricating oil

Order no. **280-1-120 217**.

12.07 Lubricating the roller presser drive gear mechanism (only for a diameter of 25 mm and 35 mm)

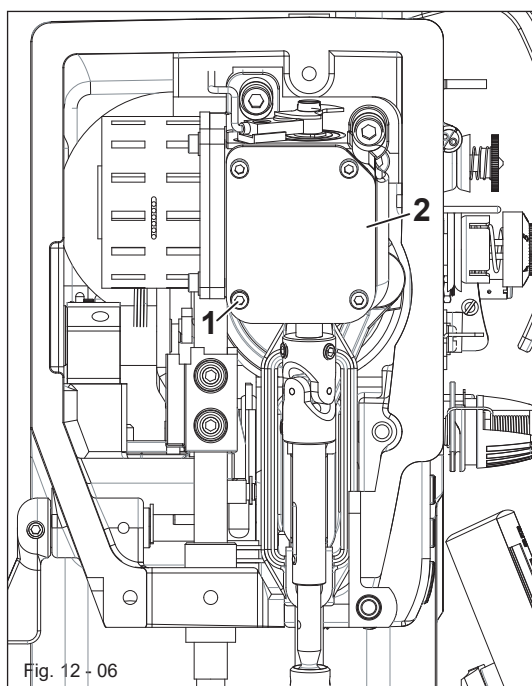

Switch off the machine!

Risk of injury due to accidental machine start-up!

- Loosen the screws 1.
- Remove the cover 2.
- Lubricate the gear mechanism.
- Fit the cover 2 again.
- Tighten the screws 1.



Only use grease with a dripping point of approx. **150 °C!**

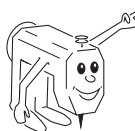

We recommend PFAFF sodium soap grease with a dripping point of approx. **150 °C.**

Order no. **280-1-120 243.**

13.02 Table top cutout

Anchor nut DIN 7965 (2x)
Order no. 12-177 106-05

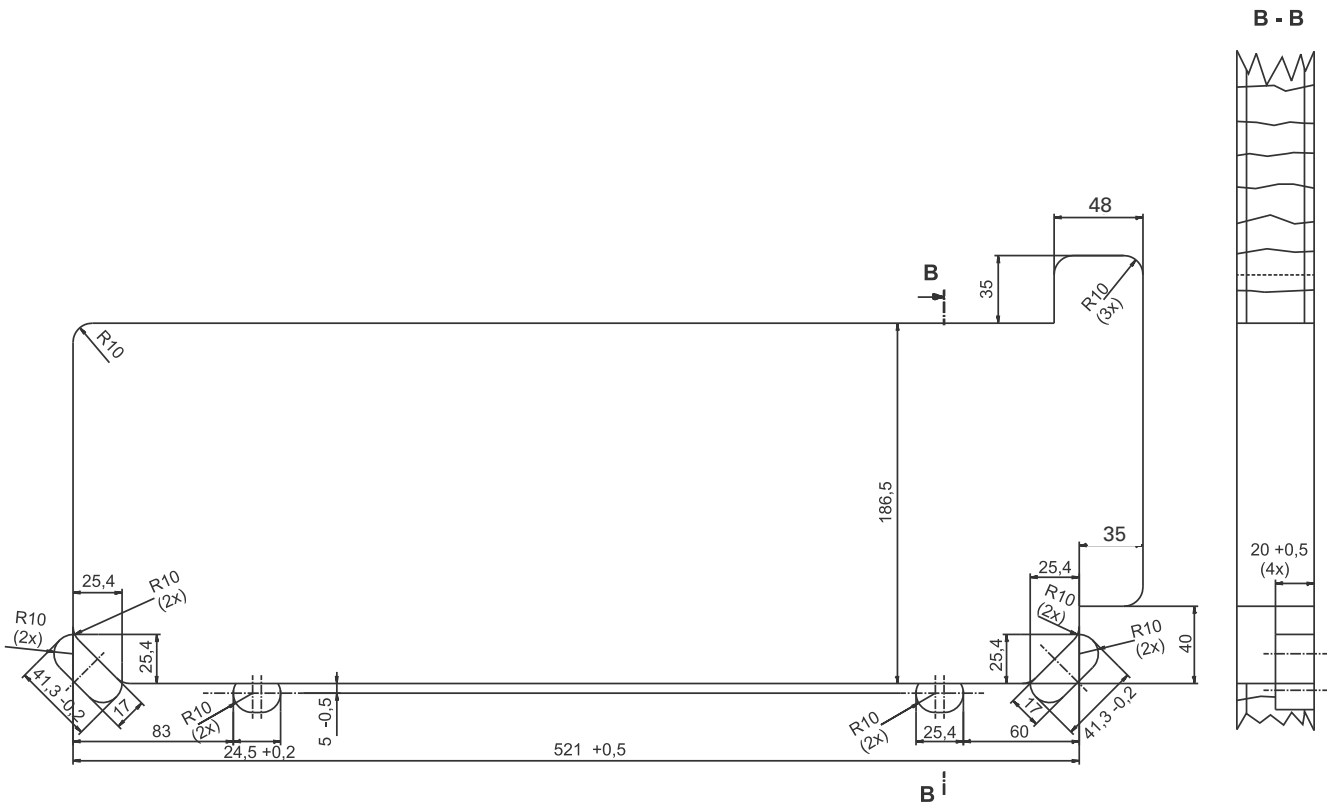
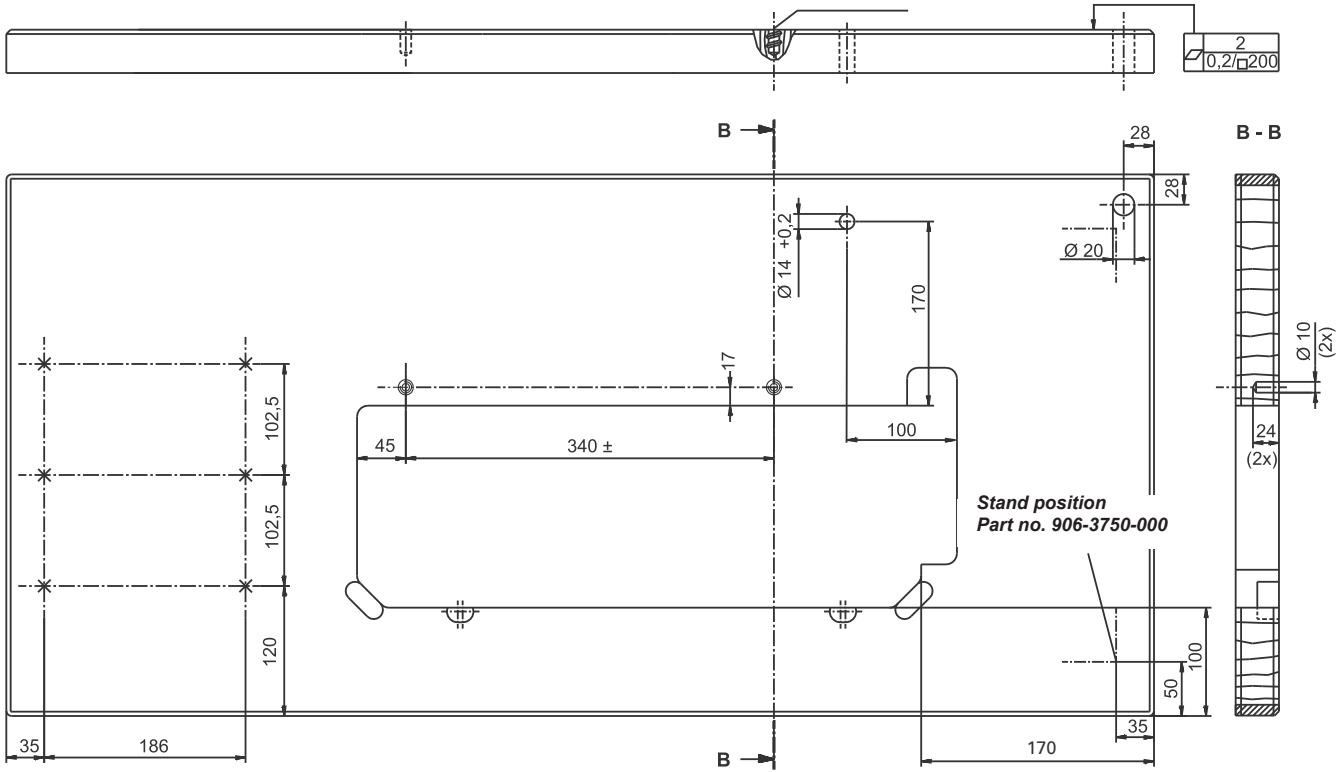

14 Wearing Parts



This list shows the most important wearing parts.

A detailed parts list for the complete machine can be downloaded at www.pfaff-industrial.de/de/service-support/downloads/technical As an alternative to the Internet download, the parts list can also be requested as a hard copy under order no. **296-12-19 401**.

91-363 048-93/001
91-363 050-93/001
91-363 052-93/001

Rollfuss 25 mm Ø
Rollfuss 30 mm Ø
Rollfuss 35 mm Ø

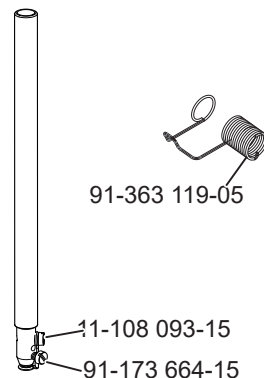
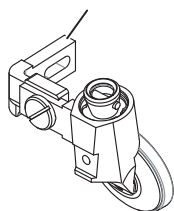

91-363 119-05

11-108 093-15

91-173 664-15

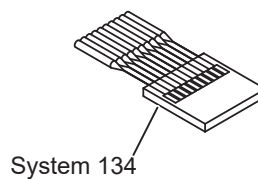

System 134

91-263 490-91 B
91-263 495-91 C

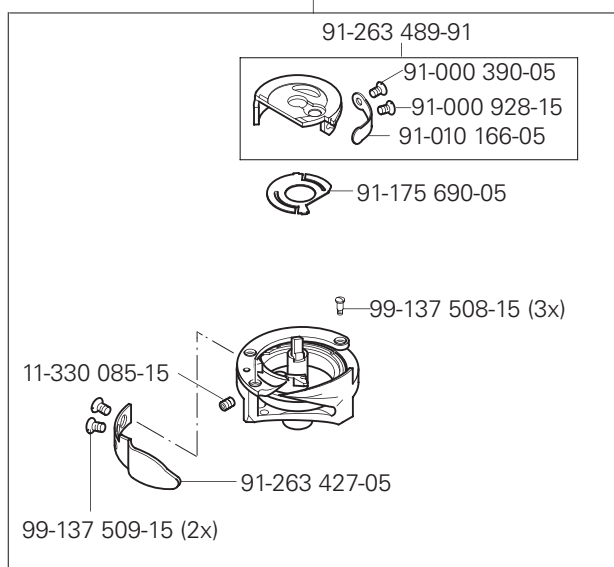

95-774 789-05



Wearing Parts

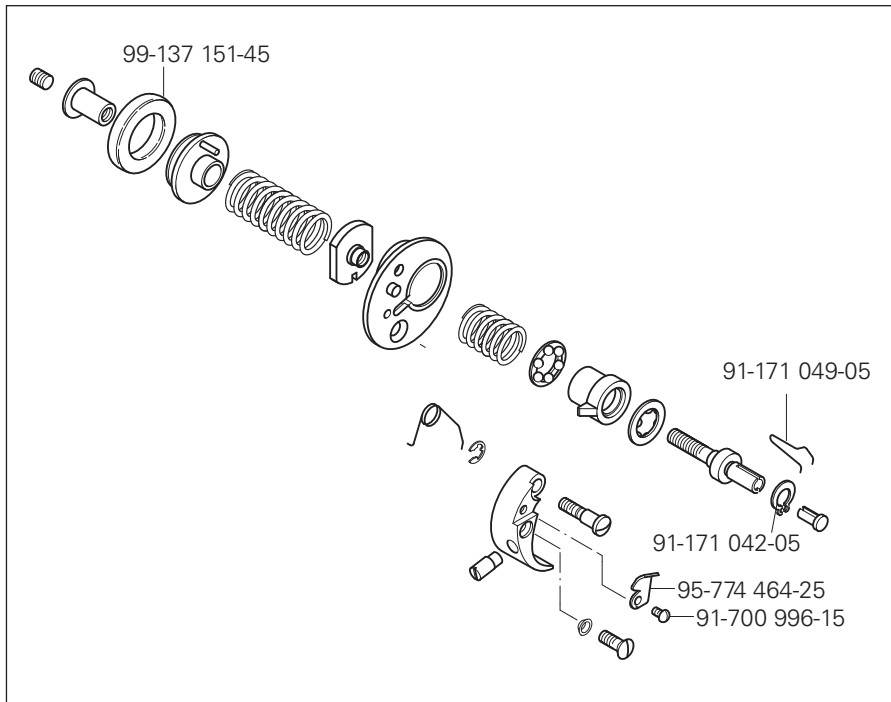
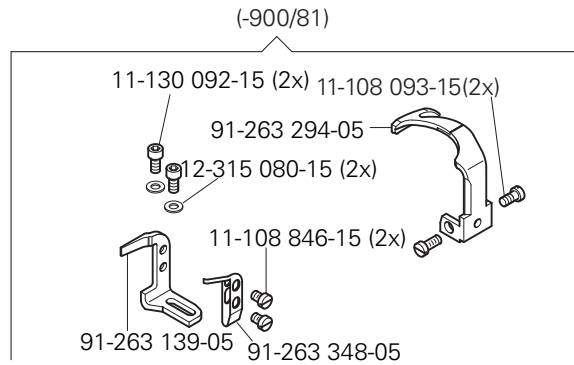

1571-725/..

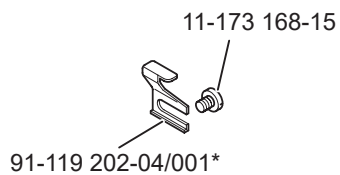

1591-725/..

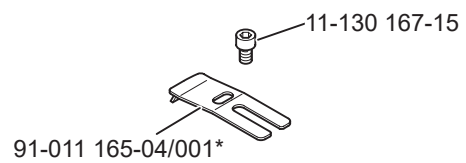

* More knives see parts list

PFAFF[®] Industrial

The logo for KSL, featuring a stylized blue and black 'K' followed by the letters 'KSL' in a bold, sans-serif font.

Europäische Union
Wachstum durch Innovation – EFRE

PFAFF Industriesysteme und Maschinen GmbH

Hans-Geiger-Str. 12 - IG Nord
D-67661 Kaiserslautern

Tel.: +49-6301 3205 - 0

Fax: +49-6301 3205 - 1386

E-mail: info@pfaff-industrial.com