

3588 -12/021 -22/021

TEILELISTE

PARTS LIST

LISTE DE PIÈCES

LISTA DE PIEZAS

Diese Teileliste hat für Maschinen ab nachfolgender
Seriennummer Gültigkeit:

This parts list applies to machines from the following
serial numbers onwards:

Cette liste de pièces est valable pour les machines au
numéros de série à partir de:

Esta lista de piezas tiene validez para máquinas a partir del
número de serie siguiente:

2 784 823 →

Alle Informationen und Abbildungen waren zum Zeitpunkt der Druckgebung auf dem neuesten Stand.

Technische Änderungen vorbehalten!

Der Nachdruck, die Vervielfältigung sowie die Übersetzung - auch auszugsweise - aus PFAFF-Teilelisten ist nur mit unserer vorherigen Zustimmung und mit der Quellenangabe gestattet.

At the time of printing, all information and illustrations contained in this document were up to date.

Subject to alteration!

The reprinting, copying or translation of PFAFF Parts lists whether in whole or in part, is only permitted with our previous permission and with written reference to the source.

Au moment de la remise à l'imprimeur, toutes les informations et figures se rapportant à cette machine correspondaient à l'état actuel des connaissances.

Sous réserve de modifications techniques!

Aucune reproduction, polycopie ou traduction - même par extraits - des listes de pièces PFAFF ne peut être effectuée, à condition d'en indiquer l'origine, sans notre autorisation expresse.

Todas las informaciones e ilustraciones de este manual estaban al día en el momento de entregarse para su impresión.

¡ Salvo modificaciones técnicas!

La reimpresión, reproducción y traducción - aunque sólo sea parcial - de las listas de piezas PFAFF sólo está permitida con nuestro permiso previo e indicando la fuente.

**PFAFF Industriesysteme
und Maschinen AG**

Hans-Geiger-Str. 12 - IG Nord

D-67661 Kaiserslautern

	Seite Page Page Página
0 Wichtiger Hinweis	0 - 1
Important note	
Avis important	
Observación importante	
1 Vorwort	1 - 1
Foreword	
Avant-propos	
Notas preliminares	
2 Erläuterungen der Schlüsselzeichen	2 - 1
Explanation of key markings	
Explication des symboles	
Explicaciones de los signos clave	
3 Nähmaschine	
Sewing machine	
Tête de machine	
Máquina de coser	
3.01 Gehäuseteile	3 - 1
Housing sections	
Parties du corps	
Piezas del cárter	
3.02 Kopfteile	3 - 2
Needle head parts	
Pièces de tête	
Piezas de la cabeza	
3.03 Armteile	3 - 5
Arm parts	
Pièces de bras	
Piezas del brazo	
3.04 Grundplattenteile	3 - 12
Bedplate parts	
Pièces du plateau fondamental	
Piezas del cárter	
4 Tischplatte	4 - 1
Table top	
Plateau de table	
Tablero de costura	
5 Gestell mit Anbauteilen	5 - 1
Stand with assembly parts	
Bâti avec éléments de montage	
Bancada con piezas de montaje	
6 X-Y-Antrieb	6 - 1
X-Y drive	
Système de commande X-Y	
Grupo de accionamiento "X-Y"	
7 Stapler	7 - 1
Stacker	
Empileur	
Apilador	

	Seite Page Page Página
8 Umbugger	8 - 1
Folder	
Remplieur	
Grupo doblador	
9 Pneumatische Ausrüstung	9 - 1
Pneumatic equipment	
Equipement pneumatique	
Equipo neumático	
10 Elektrische Ausrüstung	
Electrical equipment	
Equipement électrique	
Equipo eléctrico	
10.01 Bedienfeld	10 - 1
Control panel	
Panneau de commande	
Panel de mandos	
10.02 Notausschalter und Nähmotor	10 - 2
Emergency shut-off switch and sewing motor	
Interrupteur d'arrêt d'urgence et moteur de machine à coudre	
Interruptor de emergencia y motor máquina de coser	
10.03 Zweihandbedienung	10 - 3
Operation with both hands	
Commande à deux mains	
Manejo a dos manos	
10.04 Steuergerät	10 - 4
Control device	
Boîte de commande	
Caja de mandos	
10.05 Saugeinrichtung	10 - 15
Vacuum system	
Dispositif d'aspiration	
Dispositivo de aspiración	
10.06 Stoffrückhaltevorrichtung	10 - 16
Workpiece retainer	
Dispositif de rétension du tissu	
Dispositivo de retención del material	
11 Verkleidung	11 - 1
Cover panel	
Carters	
Revestimiento	
12 Garnrollenständer	12 - 1
Reel stands	
Porte-bobines	
Portacarretes	
13 Einstellehren	13 - 1
Adjustment gauges	
Calibres	
Calibres de ajuste	

	Seite Page Page Página
14 Schmiermittel-Übersicht	14 - 1
Overview of lubricants	
Tableau de lubrifiants	
Tabla de lubricantes	
15 Optionen	
Options	
Options	
Opciones	
15.01 Höhenverstellung für Gestell	15 - 1
Vertical adjustment for frame	
Réglage de la hauteur du bâti	
Regulación de la altura del bastidor	
15.02 Transportrolle	15 - 6
Feed roller	
Galet d'entraînement	
Rodillo el transporte	
15.03 Anbausatz für Programmerkennung	15 - 7
Add-on kit for program identification	
Kit pour reconnaissance de programme	
Kit para identificación del programa	
15.04 Anbausatz für Magnet	15 - 8
Add-on kit for solenoid	
Jeu de pièces adaptables pour electro-aimant	
Juego de piezas acoplables para Electroimán	
15.05 Bausatz für breiten Saum	15 - 9
Kit for wide hem	
Kit pour ourlet large	
Juego de montaje para dobladillo ancho	
15.06 Ablagebox	15 - 10
Collection box	
Boîte à prince	
Caja de apilado	
15.07 Halter für Laser	15 - 10
Laser part set holder	
Support à laser	
Sujeción de laser	
15.08 Fußtaster mit Leitung	15 - 11
Foot control with cord	
Interrupteur au pied, avec câble	
Interruptor de pie, con cable	
15.09 Teilesatz vollst. (Standardausführung)	15 - 12
Part set assy. (Standard version)	
Je de pièces complète (Version standard)	
Juego de piezas compl. (Tipo estándar)	
15.10 Teilesatz für Etiketten	15 - 16
Part set for labels	
Jeu de pièces pour les étiquettes	
Juego de piezas para etiquetas	

	Seite Page Page Página
15.11 Teilesatz für Multisize	15 - 20
Multi-size part set	
Jeu de pièces pour multi-taille	
Juego de piezas para tallas múltiples	
15.12 Teilesatz für Patten	15 - 22
Part set for flaps	
Jeu de pièces pour pattes	
Juego de piezas para solapas de bolsillo	
15.13 Teilesatz für variablen Nähslitz	15 - 26
Part set for variable sewing slot	
Jeu de pièces pour fente variable de couture	
Juego de piezas para ranura variable de costura	
15.14 Anbausatz für vorgebuggte Taschen	15 - 28
Add-on kit for pre-folded pockets	
Kit pour poches conformées	
Conjunto de piezas para bolsillo predoblado	
15.15 Teilesatz zum Abschalten der Saugluft	15 - 29
Part set to switch off suction	
Jeu de pièces pour arrêter d'aspiration à air	
Juego de piezas para desactivar el aire aspirante	
15.16 Hubvorrichtung	15 - 30
Lifting mechanism	
Mécanisme élévateur	
Dispositivo de elevación	
15.17 Adapter für Teilesätze der PFAFF 3568	15 - 31
Gauge parts adapter for the PFAFF 3568	
Adaptateur de kits pour la PFAFF 3568	
Adaptador para juegos de piezas de la PFAFF 3568	
16 Abweichende Teile der PFAFF 3588-22/021	16 - 1
Different parts for PFAFF 3588-22/021	
Pièces divergentes de la PFAFF 3588-22/021	
Piezas de la PFAFF 3588-22/021 que son diferentes	
17 Index (Teilenummern / Seitenzahlen)	17 - 1
Index (part numbers / page numbers)	
Index (numéros de pièces, de pages)	
Index (números de pieza / números de página)	

Achtung!



Wir machen ausdrücklich darauf aufmerksam, daß Ersatz- und Zubehörteile, die nicht von uns geliefert werden, auch nicht von uns geprüft und freigegeben sind. Der Einbau und / oder die Verwendung solcher Produkte kann daher u. Umständen konstruktiv vorgegebene Eigenschaften Ihrer Maschine negativ verändern. Für Schäden, die durch die Verwendung von Nicht-Originalteilen entstehen, übernehmen wir keine Haftung!

Caution!



We warn you expressively that spare parts and accessories that are not supplied by us are not tested and released by us. Fitting or using these products may therefore have negative influences on features that depend on the machine design. We are not liable for any damage caused by the use of non-Pfaff parts!

Attention!



Nous attirons expressément votre attention sur le fait que les pièces de rechange et accessoires qui n'ont pas été livrés par nous n'ont pas non plus été contrôlés et agréés par nous. C'est pourquoi le montage et/ou l'utilisation de telles pièces peut éventuellement entraîner l'altération des caractéristiques de construction de votre machine. Par conséquent, nous n'assumons aucune responsabilité pour les dommages causés par l'emploi de pièces qui ne sont pas d'origine!

¡Atención!



Se hace observar que en el caso de piezas de recambio y accesorios que no hayan sido suministrados por nosotros, quiere decir que non han sido sometidas por nuestra parte a un control y que no se les ha dado el visto bueno. Por esta razón, el montaje y/o empleo de tales productos puede repercutir negativamente en las características previstas en su máquina. ¡Para los daños que eventualmente pudiesen presentarse al utilizar piezas no originales, no asumimos ninguna garantía!

- Die Seriennummer der Maschine, für die diese Teileliste Gültigkeit hat, ist auf der Titelseite aufgeführt.
 - Alle Teile sind so abgebildet, wie sie in der Maschine funktionsmäßig zusammengehören.
 - Gestrichelt dargestellte Teile zeigen angrenzende Teile aus anderen Funktionsgruppen.
 - Im oberen Teil der Bildseiten befindet sich eine Gesamtansicht der Maschine .
 - Der Einbauort der dargestellten Teile wird durch eine gerasterte Fläche gekennzeichnet.
 - Einrahmungen auf den Bildseiten zeigen, aus welchen Einzelteilen sich die Gruppenteile zusammensetzen.
 - Die auf den Bildseiten verwendeten Schlüsselzeichen (; 2 ; 3 usw.) sind im Kapitel "Erläuterungen der Schlüsselzeichen" aufgelistet.
-
- The serial number of the machine to which this parts list applies is indicated on the cover page.
 - All parts are illustrated in function groups with the parts which they function together with in the machine.
 - Parts illustrated with broken lines are parts from other function groups which border on the illustrated function group.
 - The above section of the page of illustrations contains a total view of the machine. The place for the installation of the parts pictured here is marked by the grid.
 - The framed-in sections on the illustration pages show the individual parts comprising a group.
 - The key markings used on the illustrated pages (; 2 ; 3 etc.) are listed in the chapter "Explanation of key markings".
-
- Le numéro de série de la machine pour laquelle cette liste de pièces est valable est indiqué sur la première page.
 - Toutes les pièces sont représentées en fonction de leur groupement fonctionnel dans la machine.
 - Les pièces hachurées indiquent les pièces limitrophes de groupes de fonctions différents.
 - La partie supérieure des pages de figures comprend une présentation globale de la machine. L'emplacement des pièces représentées est signalé par quadrillages.
 - Les parties encadrées sur les pages à illustrations représentent les pièces individuelles formant groupe.
 - Vous trouverez au chapitre "Explication des symboles" une liste des symboles utilisés sur les pages de figures (; 2 ; 3 etc.)
-
- El número de serie de la máquina para la cual tiene validez esta lista de piezas va indicado en la página de título.
 - Todas las piezas están ilustradas tal como aparecen en la máquina para su funcionamiento.
 - Las piezas representadas con rayitas muestran piezas colindantes de otros grupos de funciones.
 - En la parte superior de las páginas ilustradas se puede ver una vista en conjunto de la máquina.
 - El lugar de montaje de la pieza representada va caracterizada mediante una superficie reticulada.
 - Los recuadros en las páginas ilustradas indican las piezas individuales de que se componen los grupos.
 - Los signos clave (; 2 ; 3 etc.) empleados en las páginas con ilustraciones van listados en el capítulo "Explicaciones de los signos clave".

- 3** **Geklebt**
Part cemented
Pièce collée
Pieza pegada
- 3/1** **Gesichert mit Loctite**
Secured with Loctite
Bloqué par Loctite
Asegurado con Loctite
- 3/4** **Selbstklebend**
Self-adhesive
Auto-adhésif
Autoadhesivo
- 6** **Nadeldicke und Spitzenform bei Bestellung angeben.**
Needle size and style of point to be stated on order.
Préciser la grosseur de l'aiguille et la forme de la pointe à la commande.
Grosor de aguja y forma de la punta, indíquese en los pedidos.
- 27/2** **Eingeklammerte Zahl = Dicke in mm.**
Number in brackets = thickness in mm.
Chiffre entre parenthèses = épaisseur en mm
Cifra entre paréntesis = espesor en mm.
- 27/5** **Eingeklammerte Zahl = Länge in mm.**
Number in brackets = length in mm.
Chiffre entre parenthèses = longueur en mm
Cifra entre paréntesis = largura en mm.
- 27/19** **Eingeklammerte Zahl = Stidlochbreite in mm.**
Number in brackets = needle hole width in mm.
Chiffre entre parenthèses = largeur du trou d'aiguille en mm
Cifra entre paréntesis = anchura del agujero pasante para la aguja en mm.
- 27/20** **Eingeklammerte Zahl = Stidlochdurchmesser in mm.**
Number in brackets = needle hole diameter in mm.
Chiffre entre parenthèses = diamètre du trou d'aiguille en mm
Cifra entre paréntesis = diámetro del agujero pasante para la aguja en mm.
- 28** **Sonderausführung**
Special version
Version spéciale
Tipo especial
- 32** **Beim Einbau diesesTeiles wird für die Paßgenauigkeit zum Anschlußteil keine Garantie übernommen; zweckmäßig vollständig Aggregat bestellen.**
No guarantee is assumed that this part will fit the mating part; it is best to order a complete assembly.
Aucune garantie ne pourra être assurée quant à la précision d'ajustage de cette pièce avec lapièce correspondante; il est indiqué de commander un mécanisme complet.
Al montar esta pieza no se asume garantía alguna en cuanto a la tolerancia y precisión de ajuste respecto a la pieza correspondiente; por esta razón, se recomienda pedir el grupo completo.
- 32/1** **Beim Einbau diesesTeiles ist Nacharbeit erforderlich.**
When fitting this part re-work is required.
Retouches nécessaires au montage.
Al montar esta pieza hay que retocarla antes

- 35/1** **Bei Montage vernieten.**
To be riveted after assembly.
River après montage.
Remáchese después del montaje.
- 40/2** **Tränken mit 28-011 201-44; Bestellnummer siehe Seite 14 - 1.**
Soak with 28-011 201-44; for part number see page 14 - 1.
Imbiber d'huile 28-011 201-44; n° de commande, voir page 14 - 1.
Empape con aceite 28-011 201-44; para el Número de pedido véase la página 14 - 1.
- 40/3** **Fetten mit 28-011 202-47; Bestellnummer siehe Seite 14 - 1.**
Grease with 28-011 202-47; for part number see page 14 - 1.
Graiser avec de la graisse 28-011 202-47; n° de commande, voir page 14 - 1.
Engrase con grasa 28-011 202-47; para el Número de pedido véase la página 14 - 1.
- 40/4** **Fetten mit 28-011 202-43; Bestellnummer siehe Seite 14 - 1.**
Grease with 28-011 202-43; for part number see page 14 - 1.
Graiser avec de la graisse 28-011 202-43; n° de commande, voir page 14 - 1.
Engrase con grasa 28-011 202-43; para el Número de pedido véase la página 14 - 1.
- 40/5** **Ölen mit 28-011 201-44; Bestellnummer siehe Seite 14 - 1.**
Oil with 28-011 201-44; for part number see page 14 - 1.
Huiler avec de la graisse 28-011 201-44; n° de commande, voir page 14 - 1.
Lubrifique con grasa 28-011 201-44; para el Número de pedido véase la página 14 - 1.
- 40/13** **Fetten mit 28-011 202-05; Bestellnummer siehe Seite 14 - 1.**
Grease with 28-011 202-05; for part number see page 14 - 1.
Graiser avec de la graisse 28-011 202-05; n° de commande, voir page 14 - 1.
Engrase con grasa 28-011 202-05; para el Número de pedido véase la página 14 - 1.
- 40/22** **Füllen mit 28-011 202-10; Bestellnummer siehe Seite 14 - 1.**
Top up with 28-011 202-10; for part number see page 14 - 1.
Remplir de 28-011 202-10; n° de commande, voir page 14 - 1.
Rellene con 28-011 202-10; para el Número de pedido véase la página 14 - 1.
- 81/1** **Stückzahl je nach Bedarf.**
Quantity as required.
Nombre en fonction besoin.
Cantidad según sea necesario.
- 81/3** **Verwendung je nach Bedarf.**
To be used as required.
Utilisation en fonction besoins.
Utilización según sea necesario.
- 96** **Länge angeben.**
State length.
Préciser longueur.
Indíquese la largura

3.02

Kopfteile
Needle head parts
Pièces de tête
Piezas de la cabeza PFAFF 3588-12/021

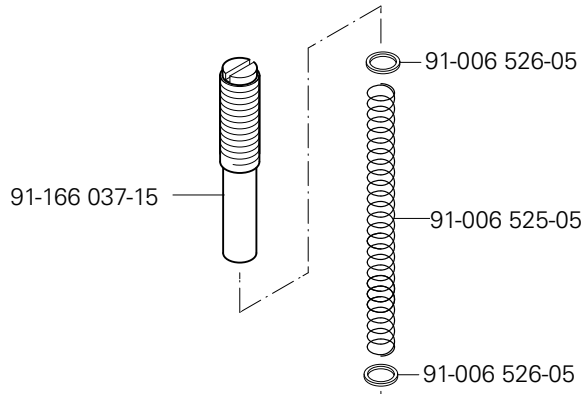
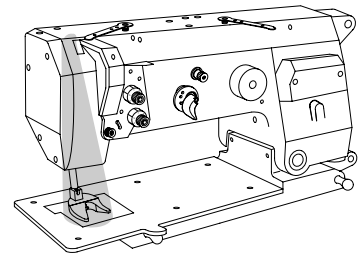

Anschluß siehe Seite 3-8
For connection see page 3-8
Raccord, cf. page 3-8
Para la conexión, véase la pág. 3-8

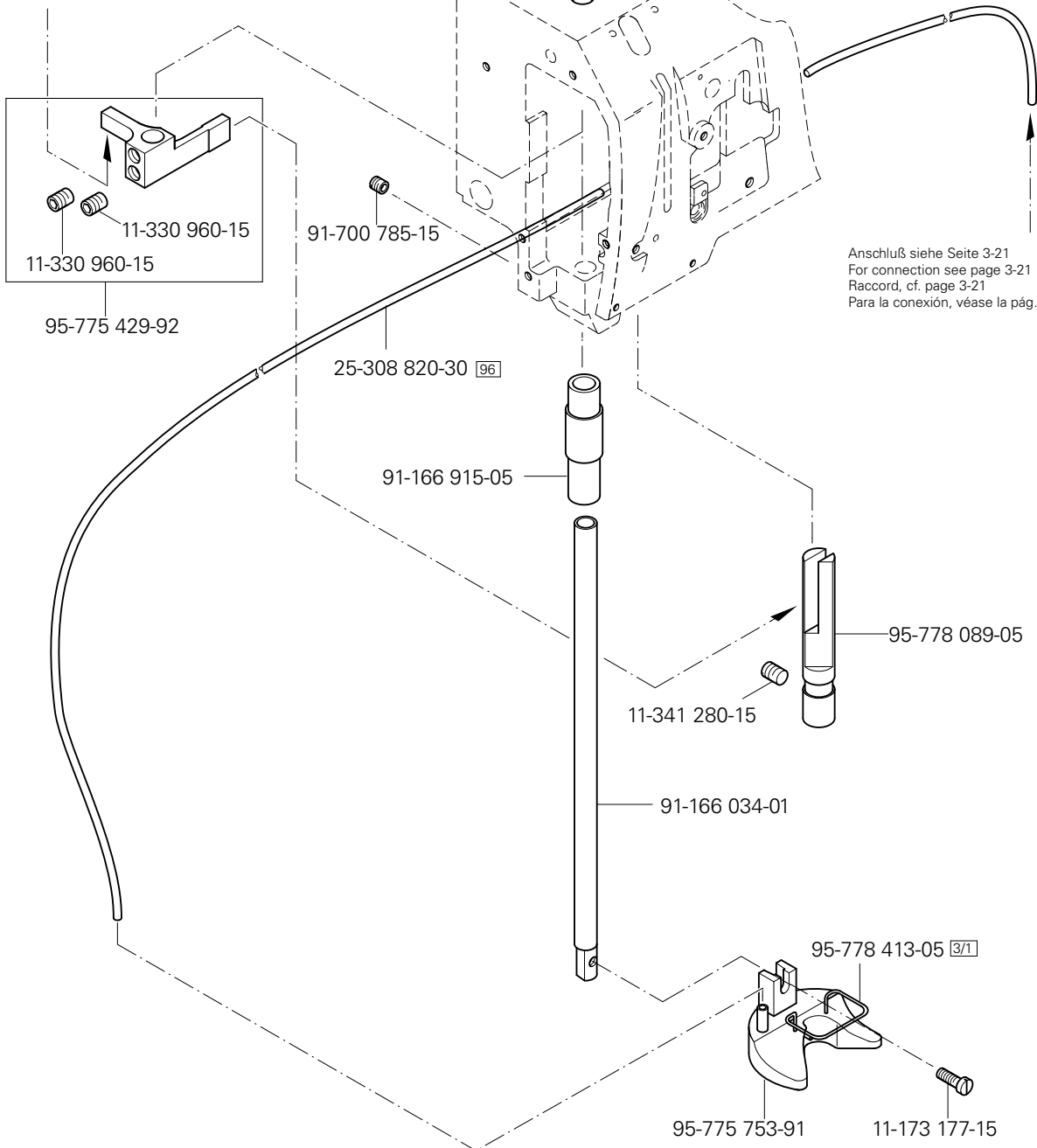

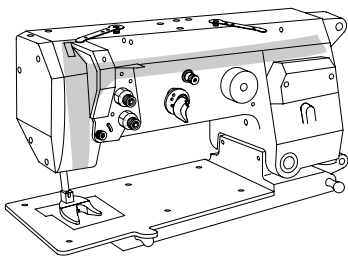

Kopfteile
Needle head parts
Pièces de tête
Piezas de la cabeza PFAFF 3588-12/021

3.02

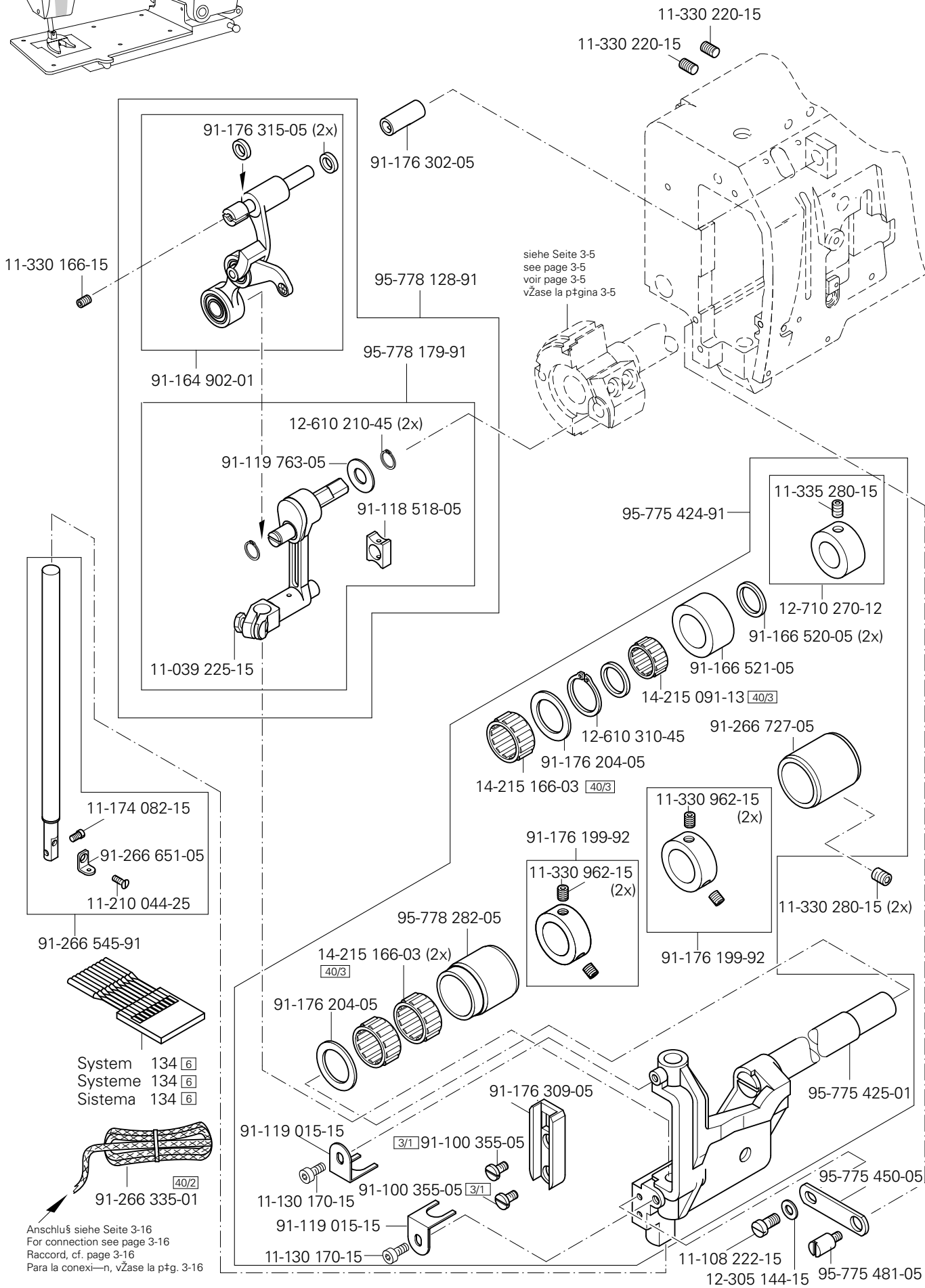

☐ siehe Kapitel 2 Erläuterung der Schlüsselzeichen
 see chapter 2 Explanation of key markings
 voir le chap. 2 Explication des symboles
 véase el Cap. 2 Explicaciones de los signos clave

3.02

Kopfteile Needle head parts Pièces de tête Piezas de la cabeza PFAFF 3588-12/021

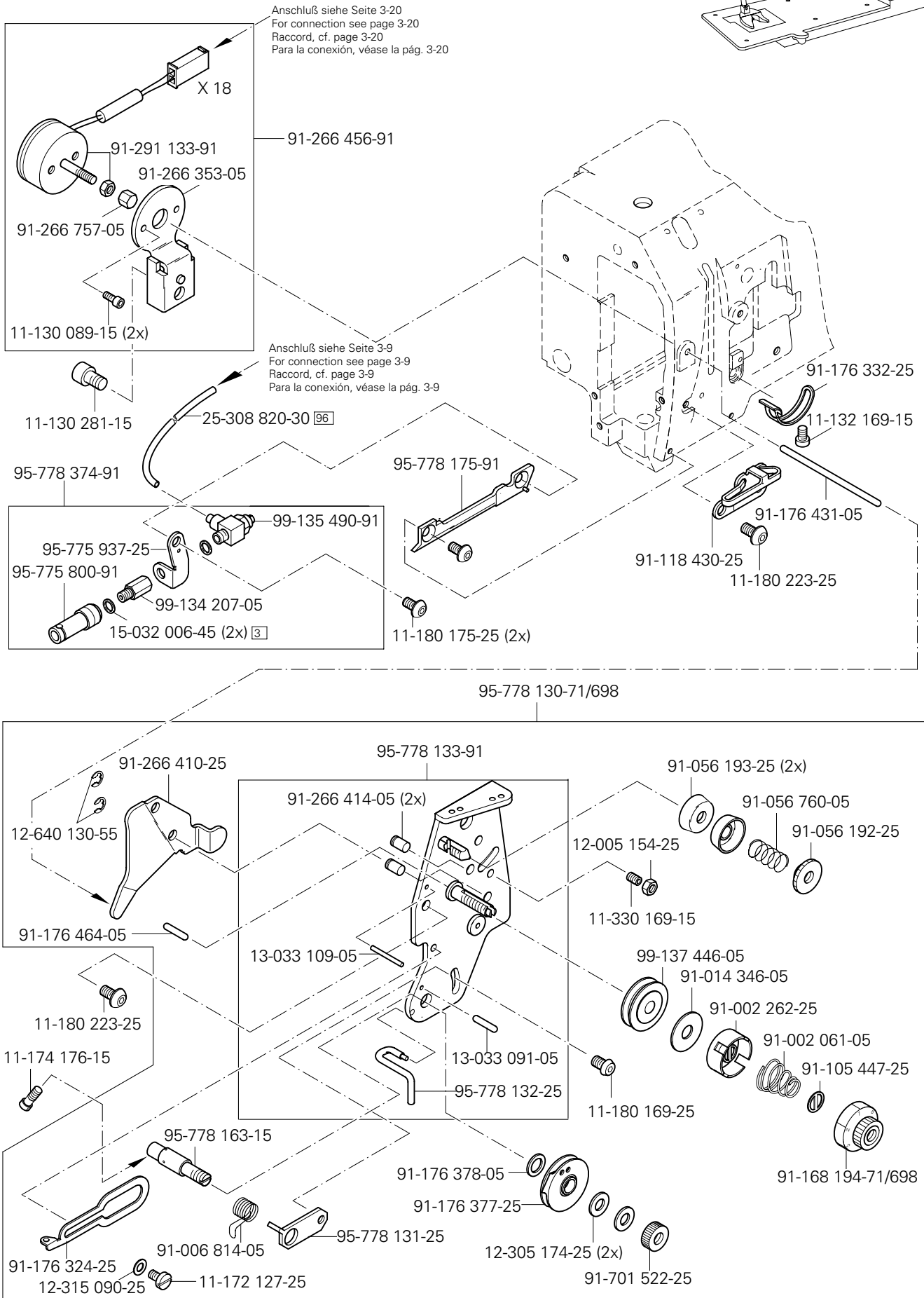
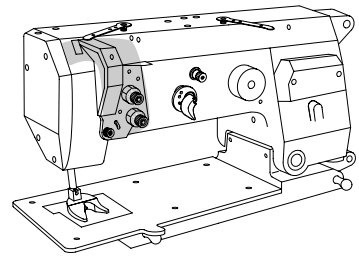

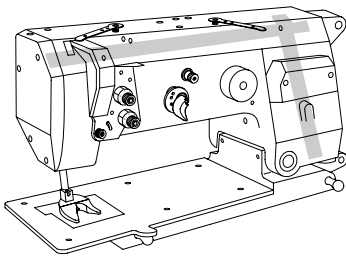

Armteile
 Arm parts
 Pièces de bras
 Piezas del brazo PFAFF 3588-12/021

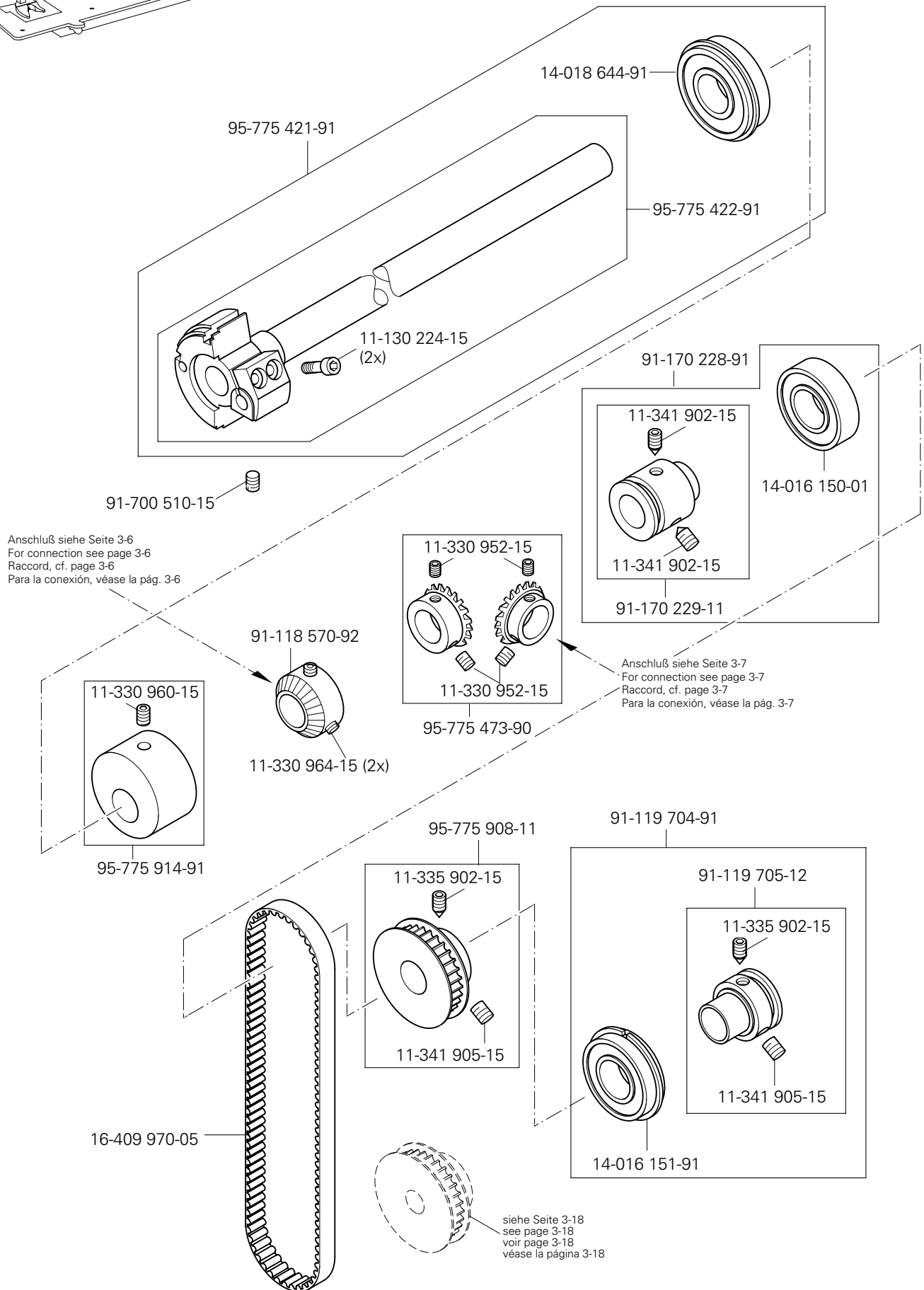

3.03

Armteile
 Arm parts
 Pièces de bras
 Piezas del brazo PFAFF 3588-12/021

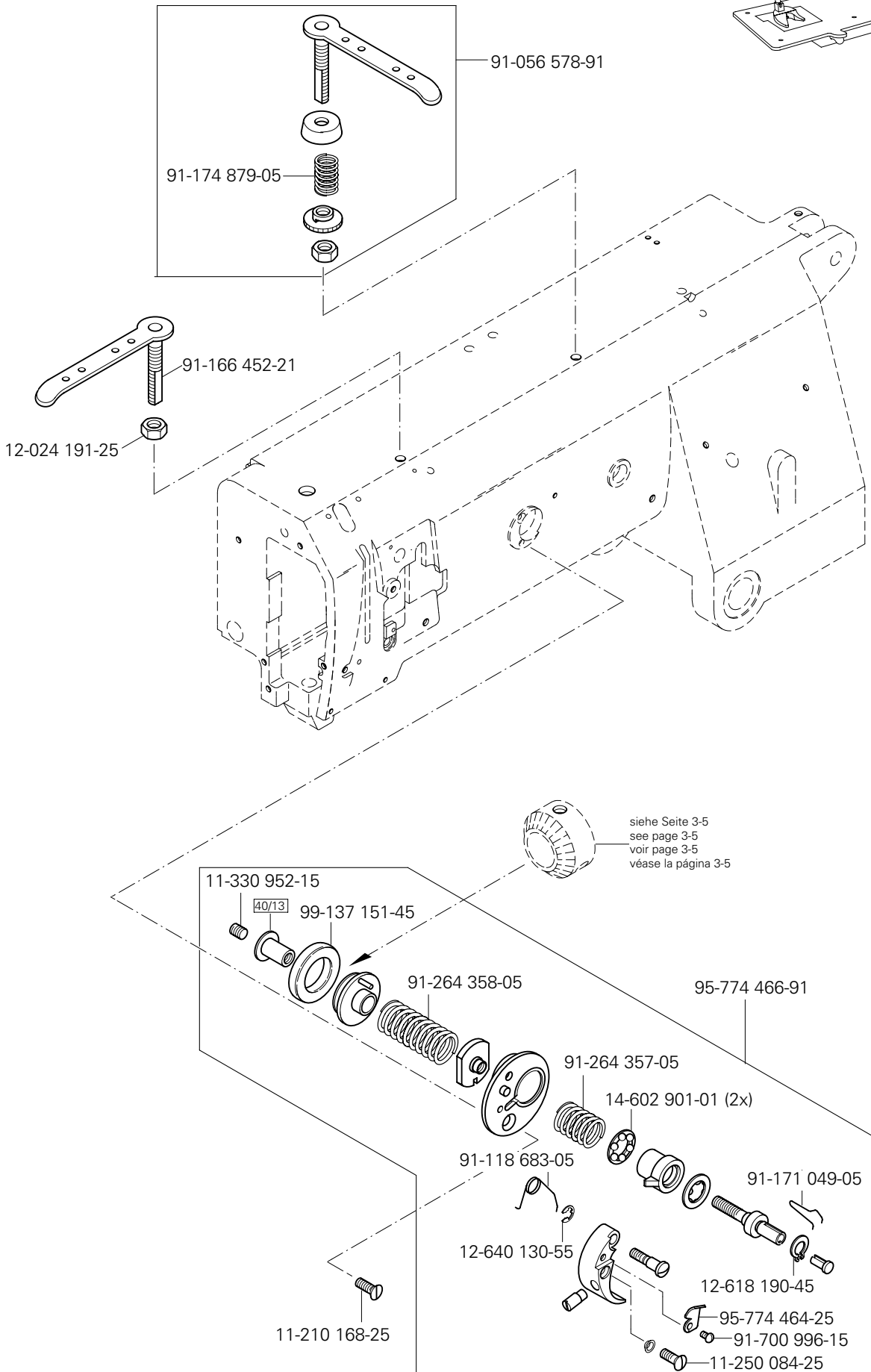
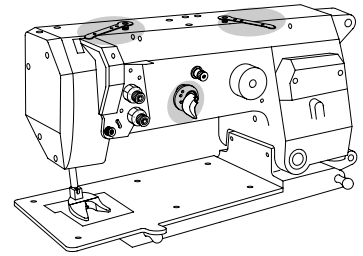

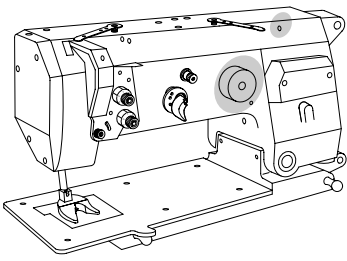

Armteile
 Arm parts
 Pièces de bras
 Piezas del brazo PFAFF 3588-12/021

3.03

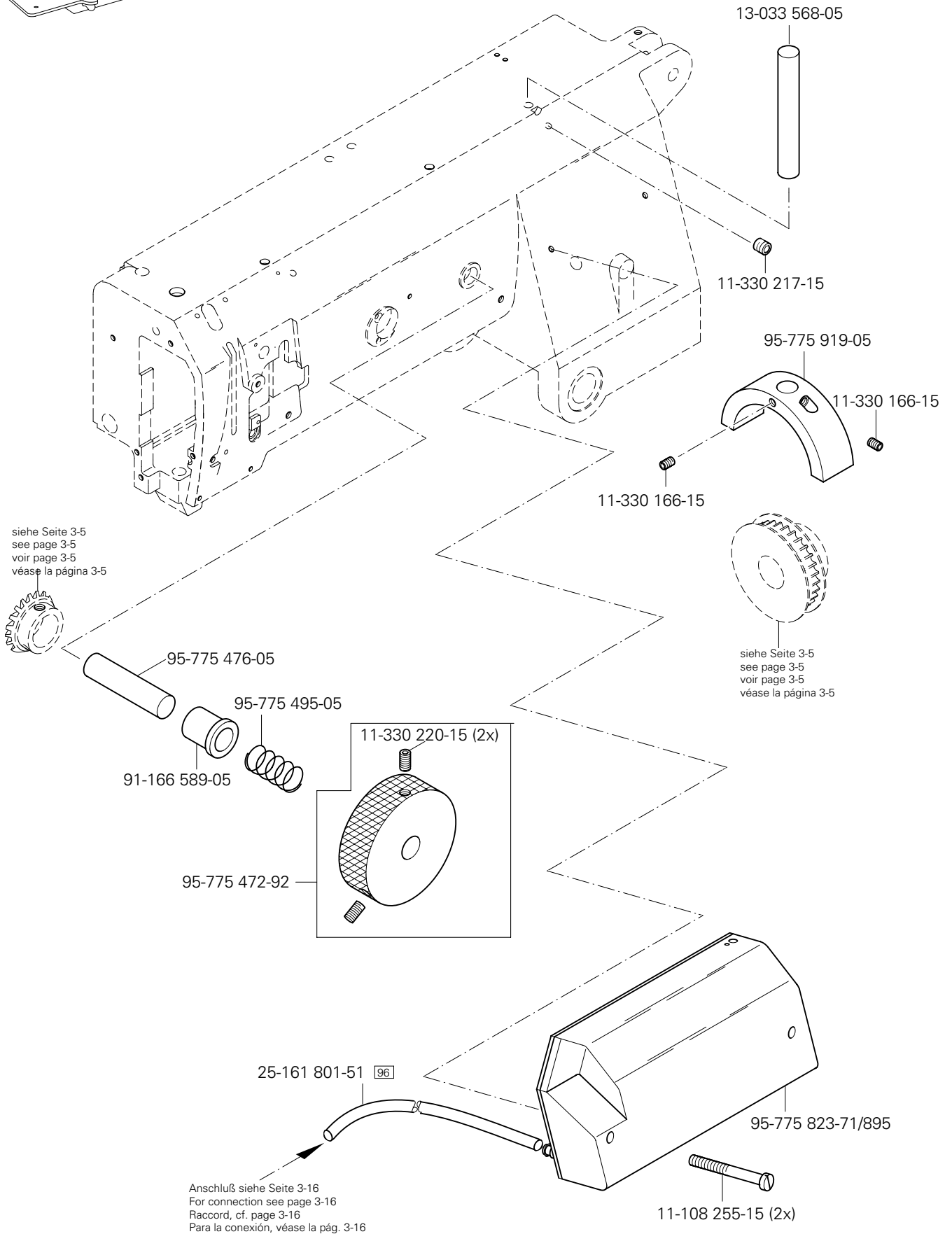

siehe Kapitel 2 Erläuterung der Schlüsselzeichen
 see chapter 2 Explanation of key markings
 voir le chap. 2 Explication des symboles
 véase el Cap. 2 Explicaciones de los signos clave

3.03

Armteile
 Arm parts
 Pièces de bras
 Piezas del brazo PFAFF 3588-12/021

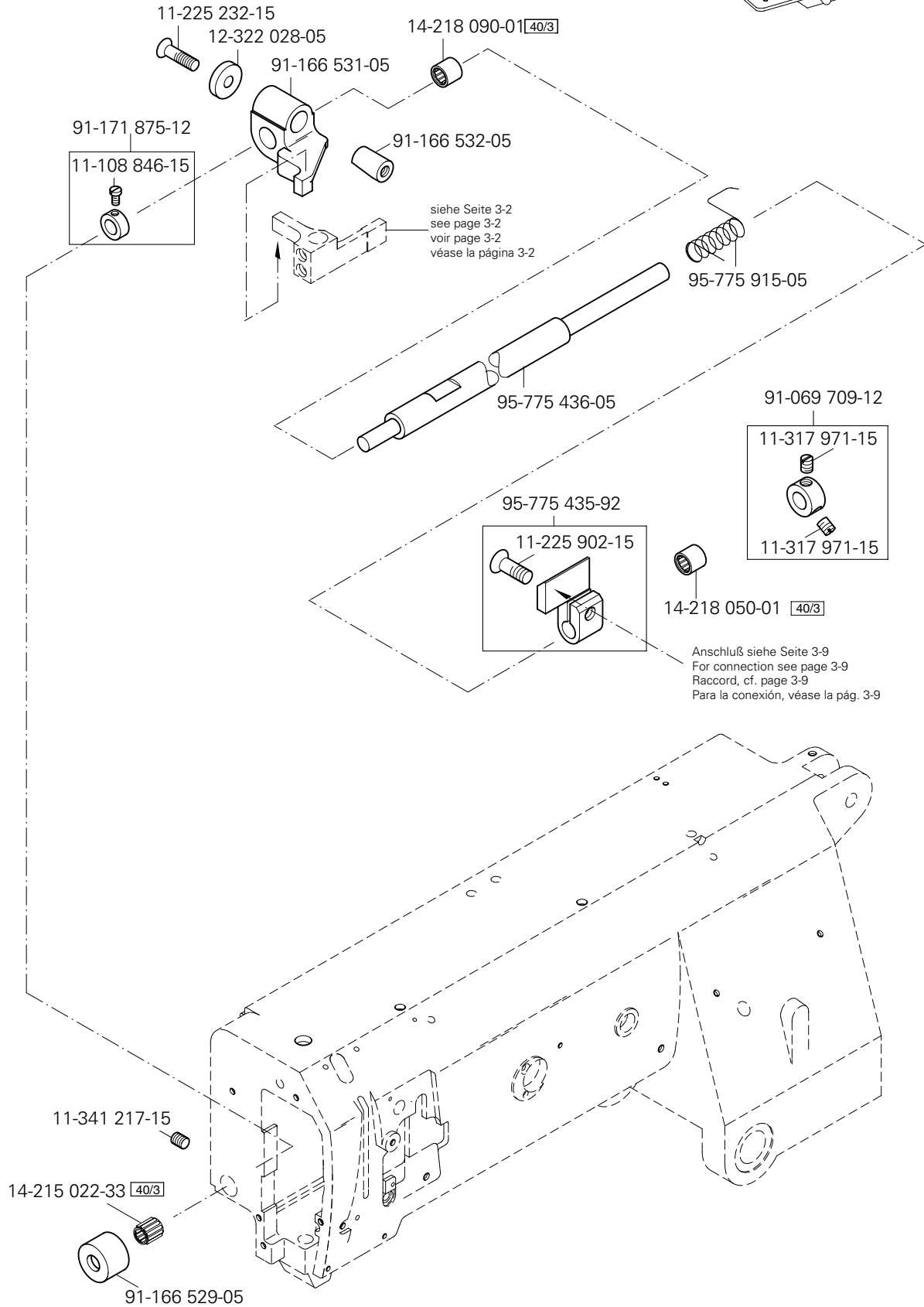
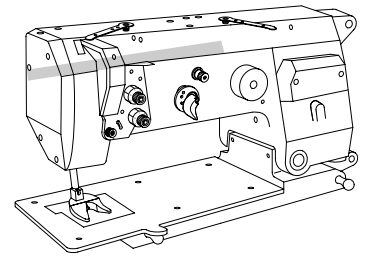

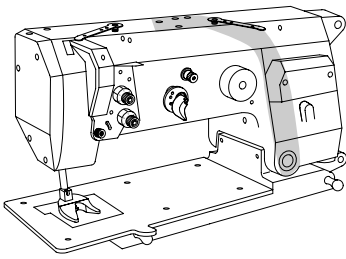

Armteile
 Arm parts
 Pièces de bras
 Piezas del brazo PFAFF 3588-12/021

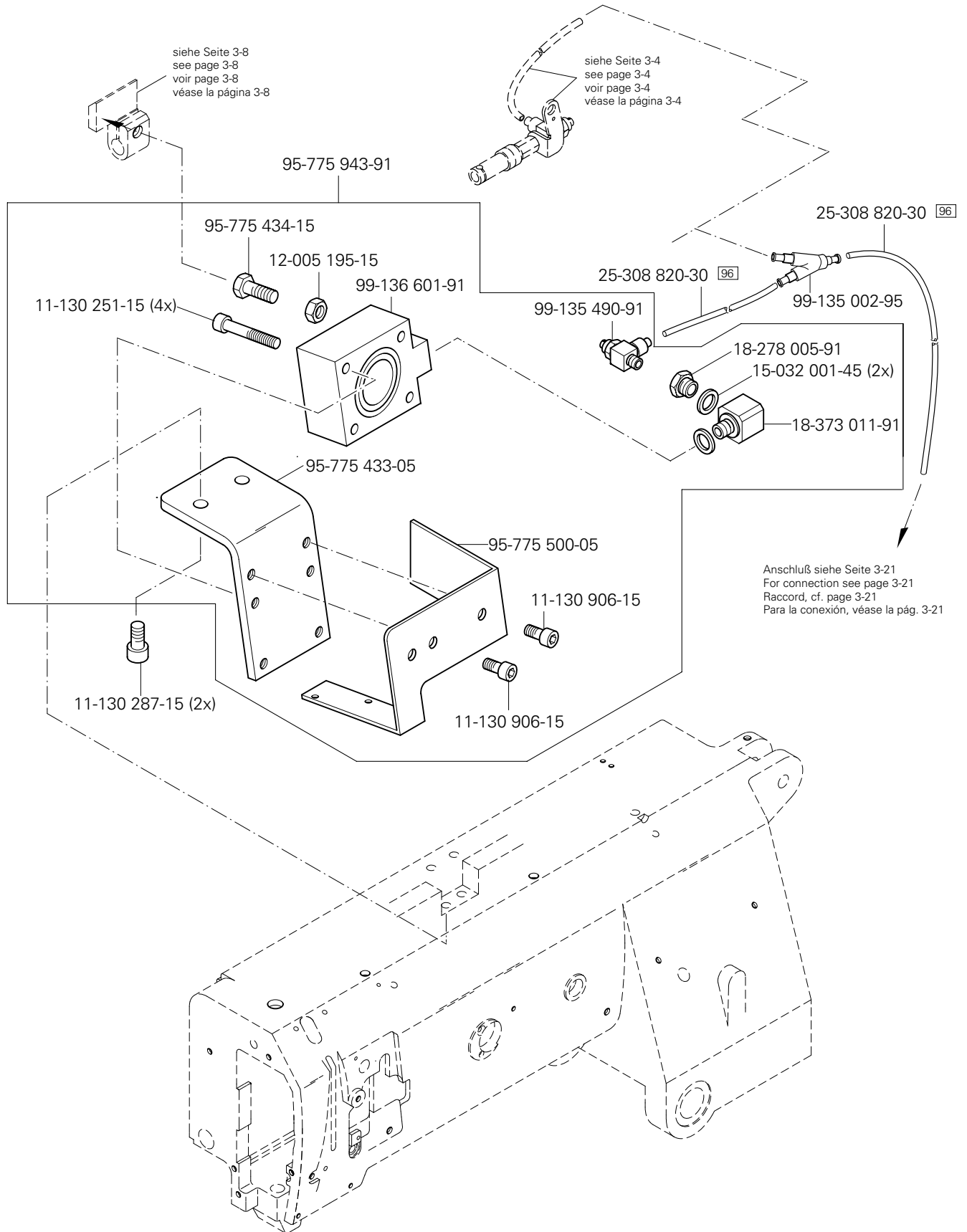

siehe Kapitel 2 Erläuterung der Schlüsselzeichen
 see chapter 2 Explanation of key markings
 voir le chap. 2 Explication des symboles
 véase el Cap. 2 Explicaciones de los signos clave

3.03

Armteile Arm parts Pièces de bras Piezas del brazo PFAFF 3588-12/021

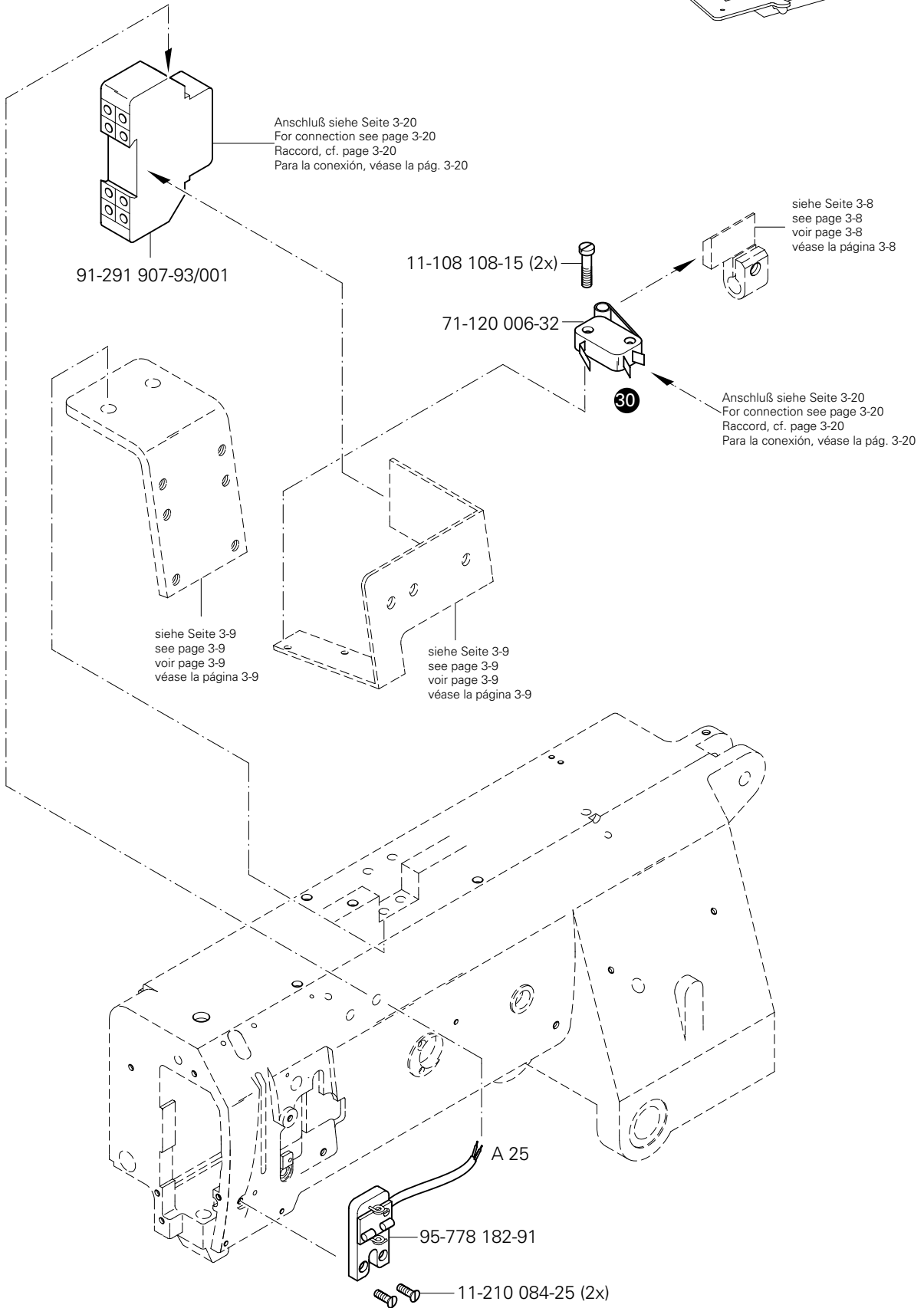
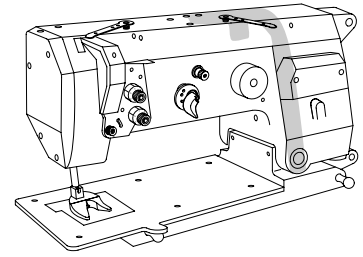

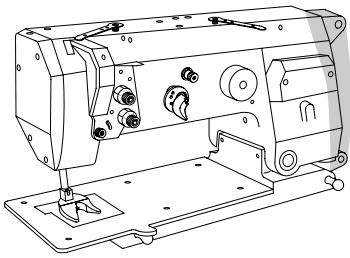

Armteile
 Arm parts
 Pièces de bras
 Piezas del brazo PFAFF 3588-12/021

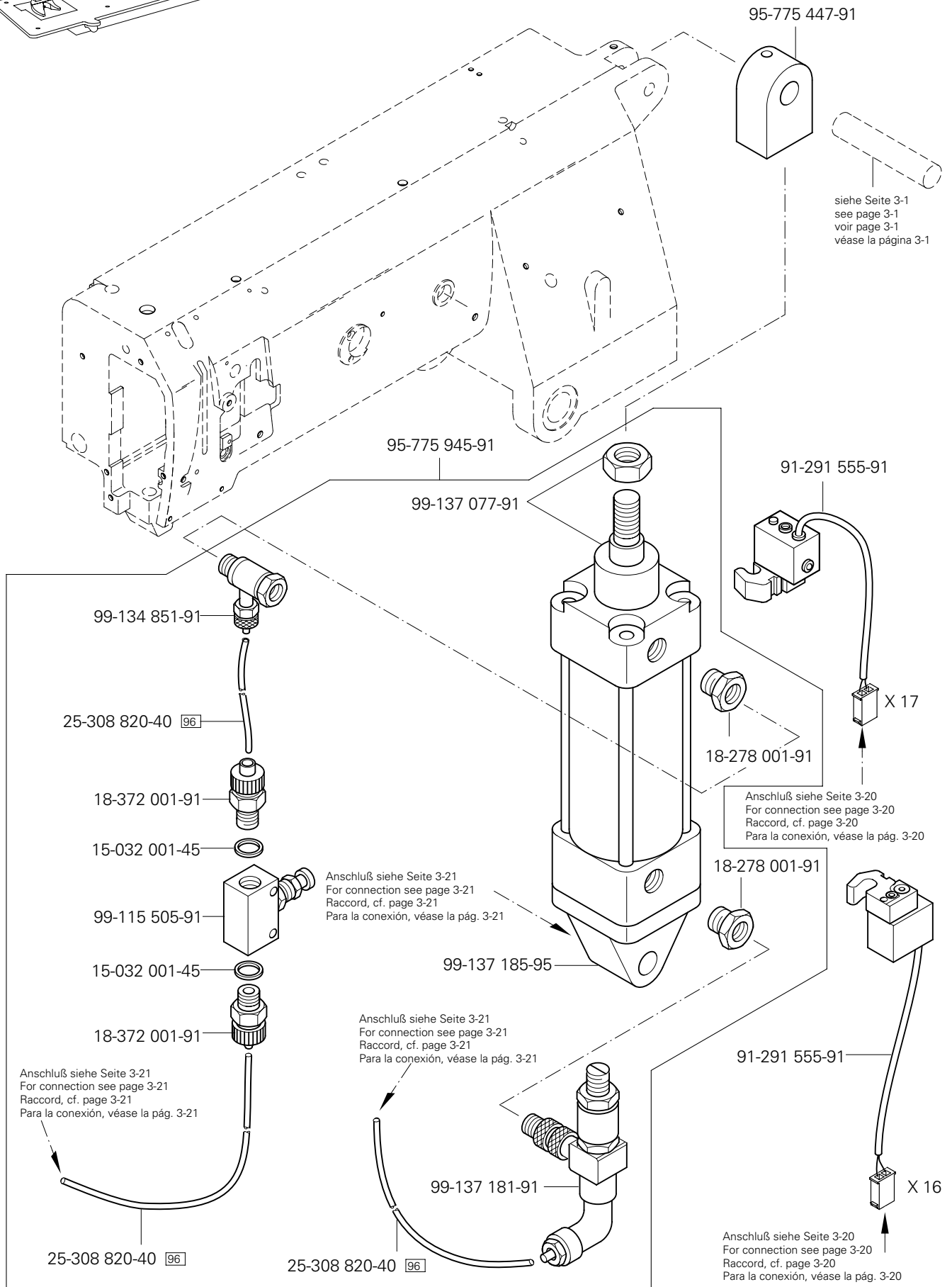

96 siehe Kapitel 2 Erläuterung der Schlüsselzeichen
 see chapter 2 Explanation of key markings
 voir le chap. 2 Explication des symboles
 véase el Cap. 2 Explicaciones de los signos clave

3.04

Grundplattenteile Bedplate parts Pièces du plateau fondamental Piezas del cárter

PFAFF 3588-12/021

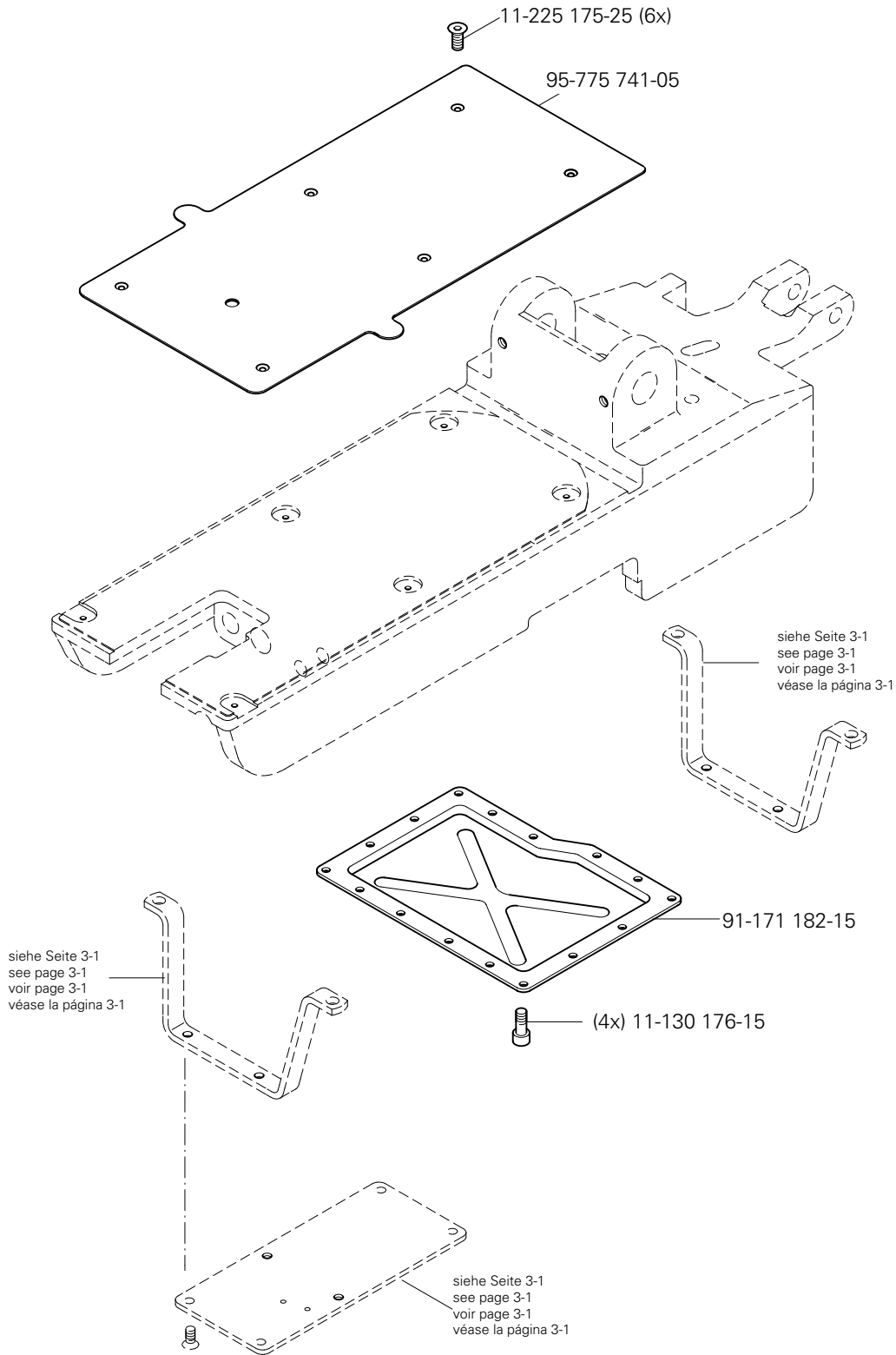
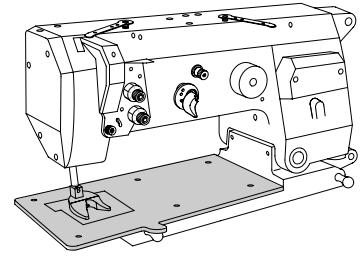

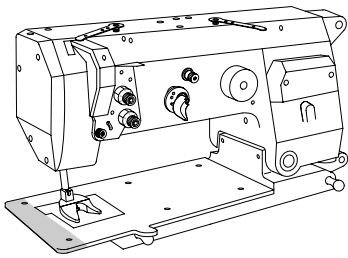

Grundplattenteile
Bedplate parts
Pièces du plateau fondamental
Piezas del cárter

PFAFF 3588-12/021

3.04

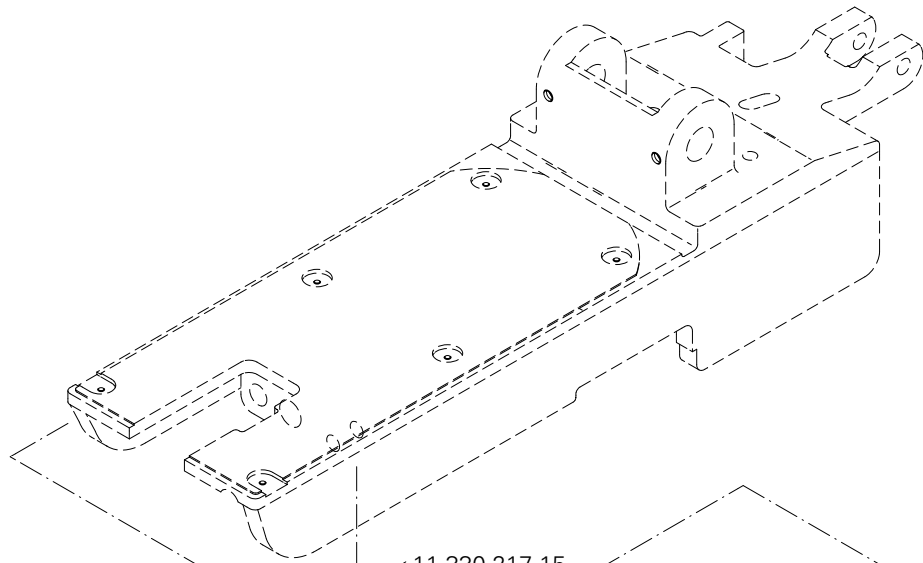

- 95-623 330-03/001 (1,0) [27/20] [28]
- 95-623 330-03/002 (1,2) [27/20]
- 95-623 330-03/003 (1,4) [27/20] [28]
- 95-623 330-03/004 (1,6) [27/20] [28]
- 95-623 330-03/005 (1,9) [27/20] [28]
- 95-623 330-03/006 (2,2) [27/20] [28]
- 95-623 330-03/007 (2,5) [27/20] [28]

11-330 217-15

Anschluß siehe Seite 3-15
For connection see page 3-15
Raccord, cf. page 3-15
Para la conexión, véase la pág. 3-15

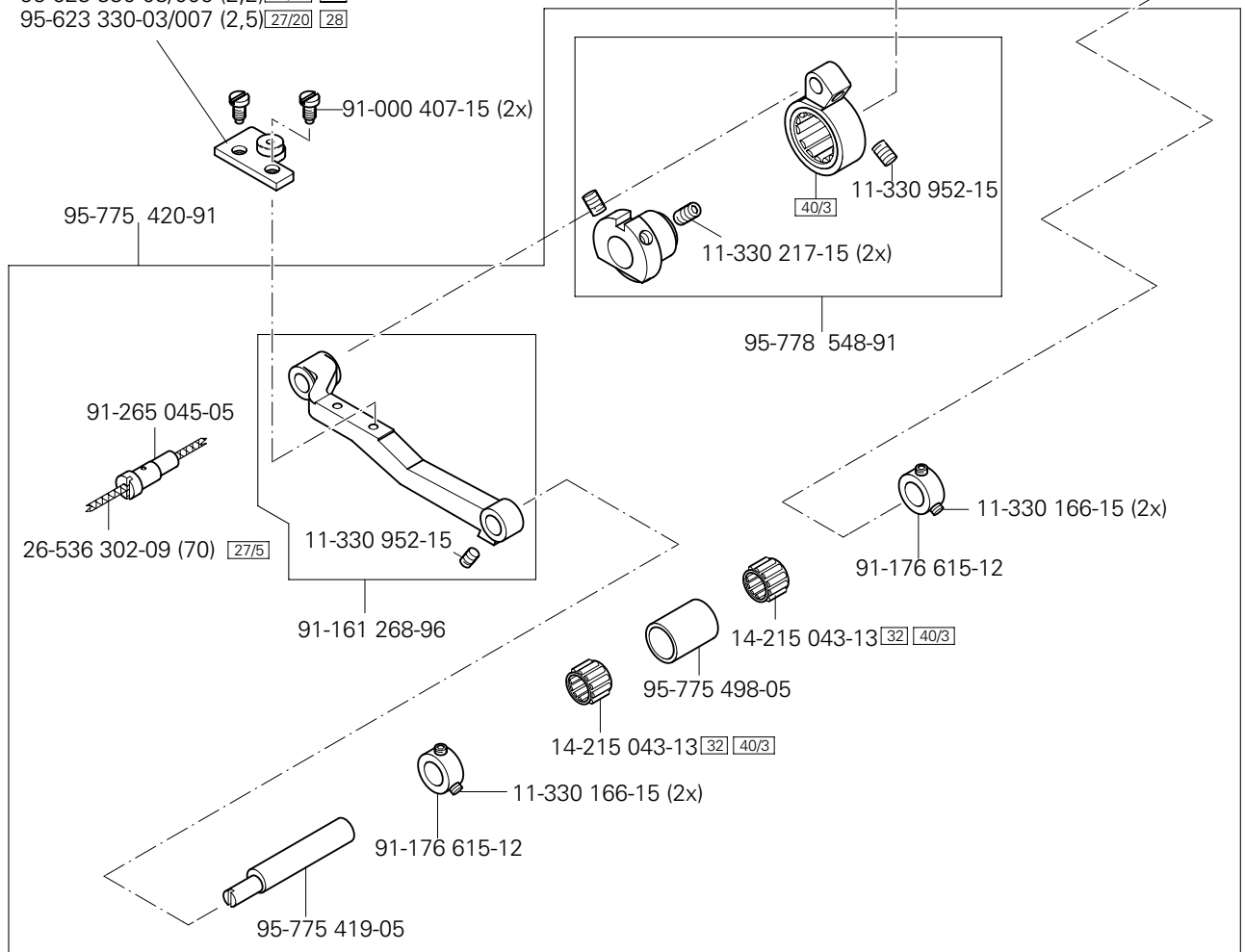

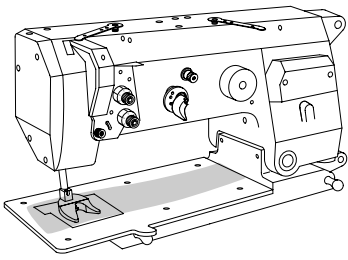

 siehe Kapitel 2 Erläuterung der Schlüsselzeichen
 see chapter 2 Explanation of key markings
 voir le chap. 2 Explication des symboles
 véase el Cap. 2 Explicaciones de los signos clave



Grundplattenteile
Bedplate parts
Pièces du plateau fondamental
Piezas del cárter

PFAFF 3588-12/021

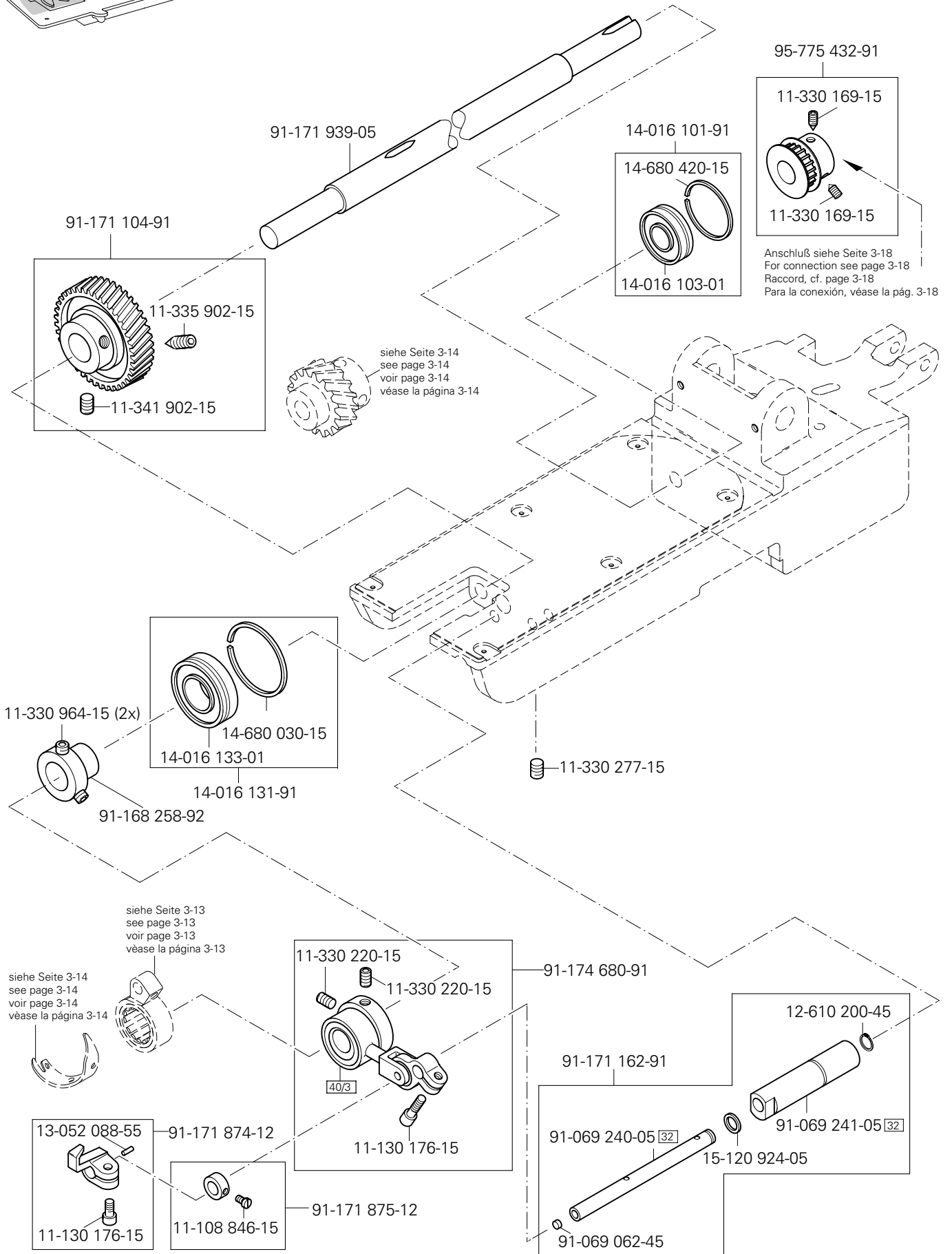
3.04



☐ siehe Kapitel 2 Erläuterung der Schlüsselzeichen
see chapter 2 Explanation of key markings
voir le chap. 2 Explication des symboles
véase el Cap. 2 Explicaciones de los signos clave

3.04

Grundplattenteile Bedplate parts Pièces du plateau fondamental Piezas del cárter

PFAFF 3588-12/021

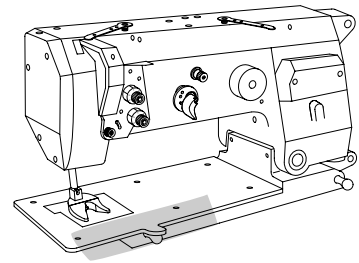

siehe Seite 3-7
see page 3-7
voir page 3-7
véase la página 3-7

siehe Seite 3-3
see page 3-3
voir page 3-3
véase la página 3-3

siehe Seite 3-17
see page 3-17
voir page 3-17
véase la página 3-17

siehe Seite 3-14
see page 3-14
voir page 3-14
véase la página 3-14

Anschluß siehe Seite 3-20
For connection see page 3-20
Raccord, cf. page 3-20
Para la conexión, véase la pág. 3-20

91-171 502-91

91-171 529-15

13-033 460-05

91-171 531-91

12-024 171-15

91-174 740-11

siehe Seite 3-14
see page 3-14
voir page 3-14
véase la página 3-14

11-130 284-15 (2x)

siehe Seite 3-1
see page 3-1
voir page 3-1
véase la página 3-1

siehe Seite 3-1
see page 3-1
voir page 3-1
véase la página 3-1

11-225 169-15 (2x)

11-108 219-15

15-125 049-05

40

18-372 008-91

15-125 049-05 (2x)

99-136 409-91

99-136 396-91

15-125 049-05

99-133 920-91

15-125 049-05 (2x)

99-136 396-91

95-775 940-01

26-536 301-09 96

25-161 801-52 96

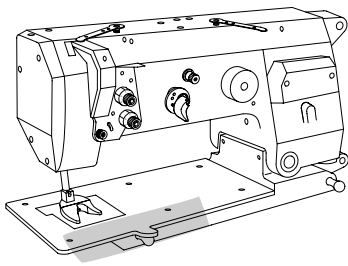

Grundplattenteile
 Bedplate parts
 Pièces du plateau fondamental
 Piezas del cárter

PFAFF 3588-12/021

3.04

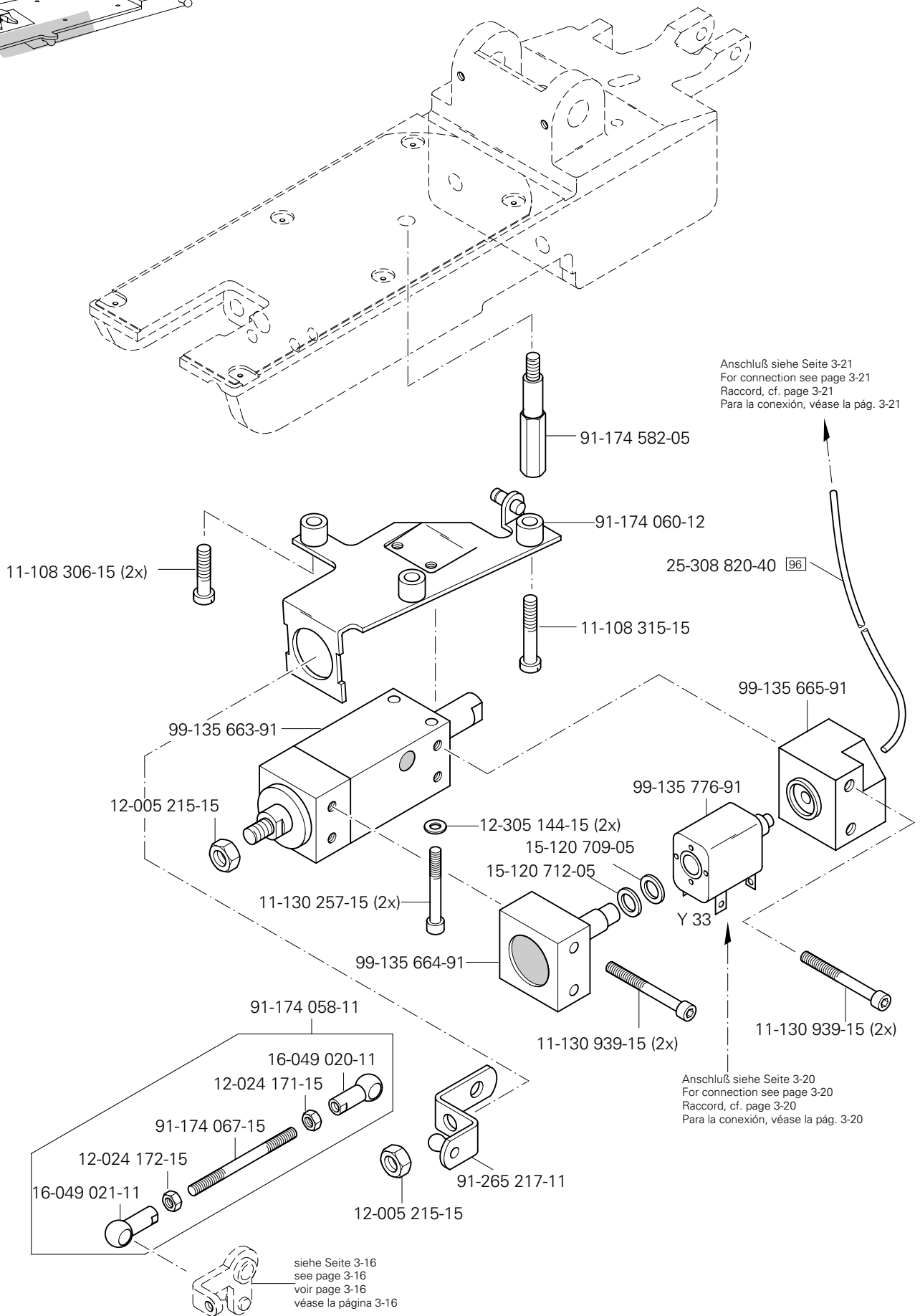

3.04

Grundplattenteile
 Bedplate parts
 Pièces du plateau fondamental
 Piezas del cárter

PFAFF 3588-12/021

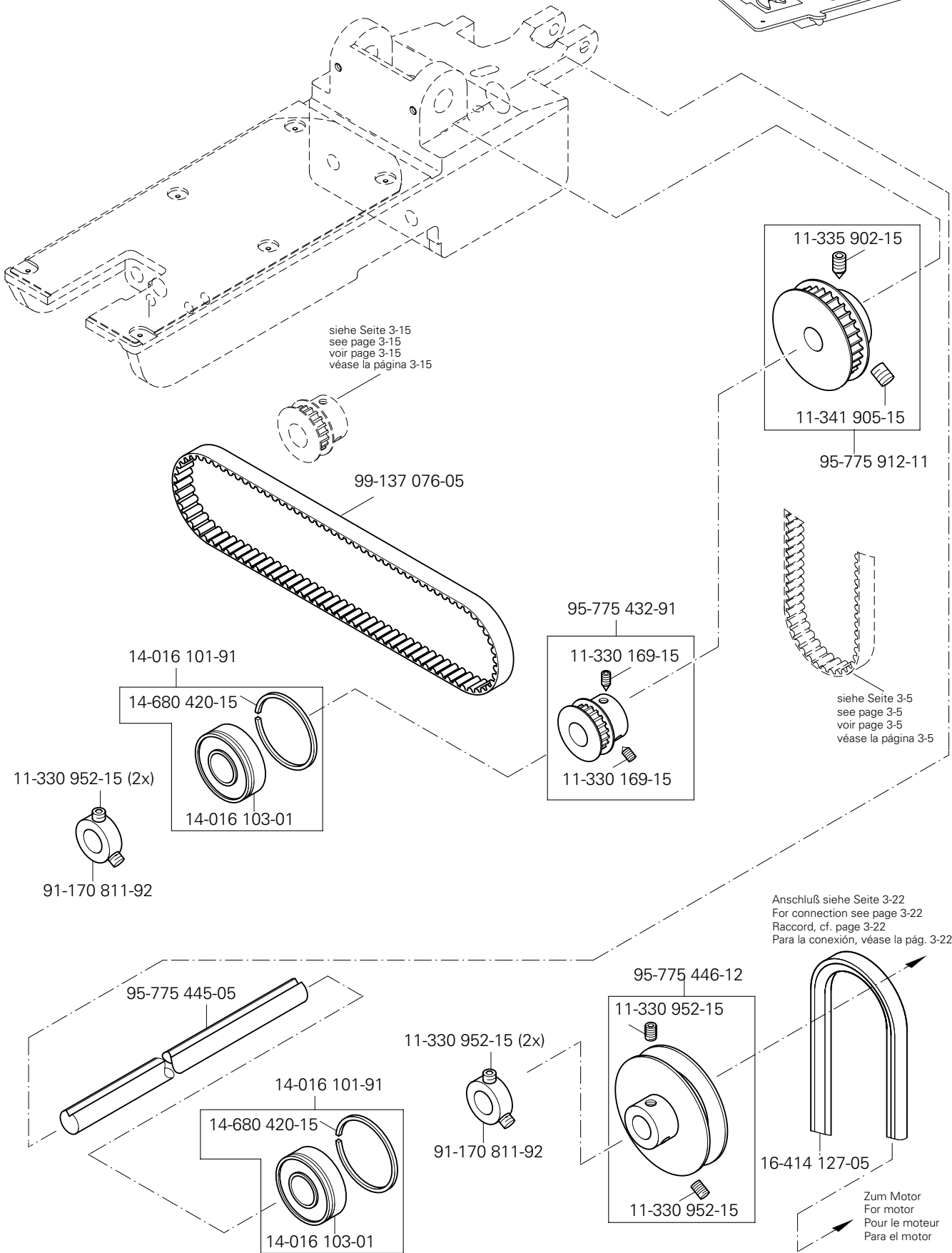
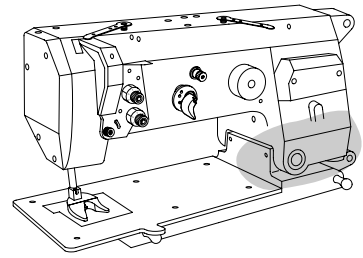

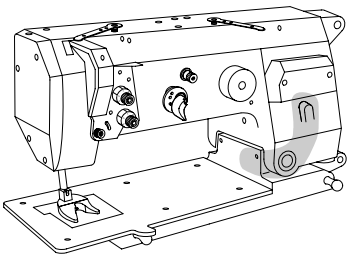

Grundplattenteile
 Bedplate parts
 Pièces du plateau fondamental
 Piezas del cárter

PFAFF 3588-12/021

3.04

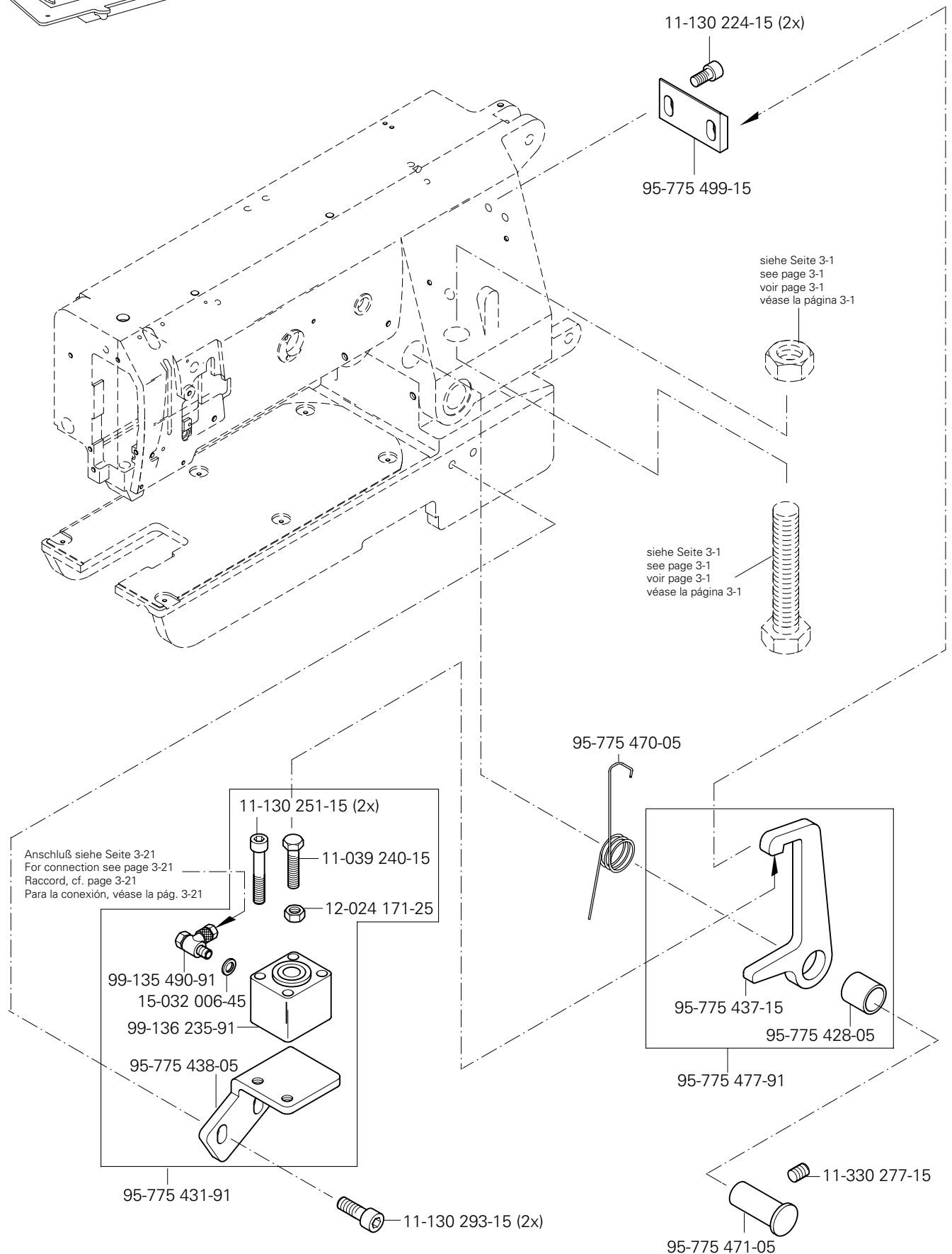

3.04

Grundplattenteile Bedplate parts Pièces du plateau fondamental Piezas del cárter

PFAFF 3588-12/021

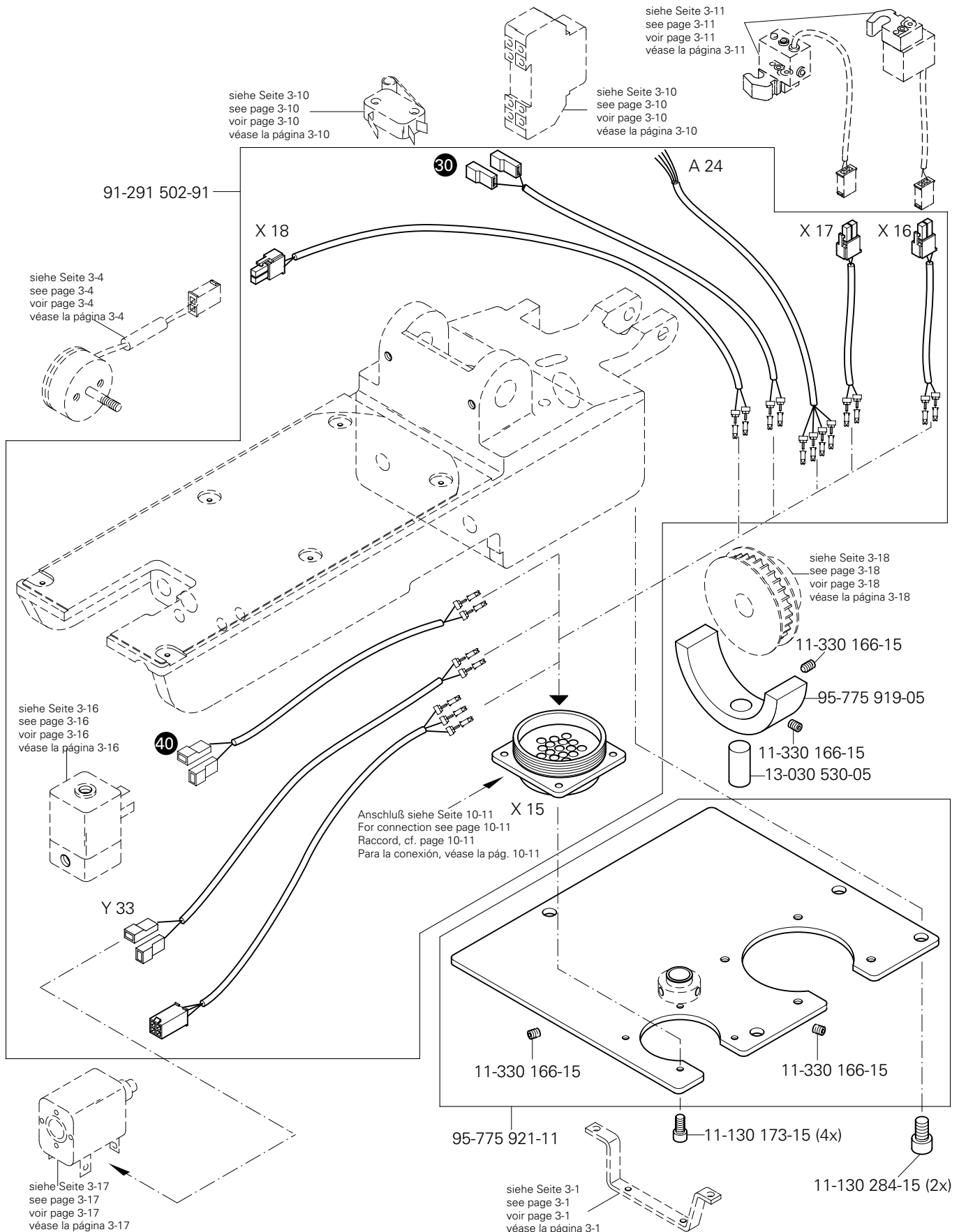
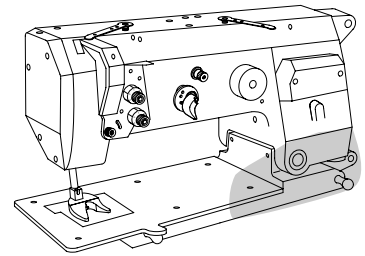

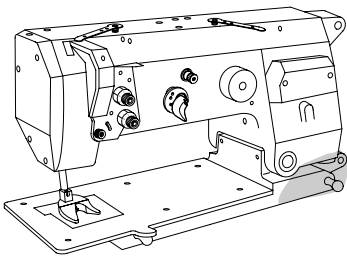

Grundplattenteile
Bedplate parts
Pièces du plateau fondamental
Piezas del cárter

PFAFF 3588-12/021

3.04

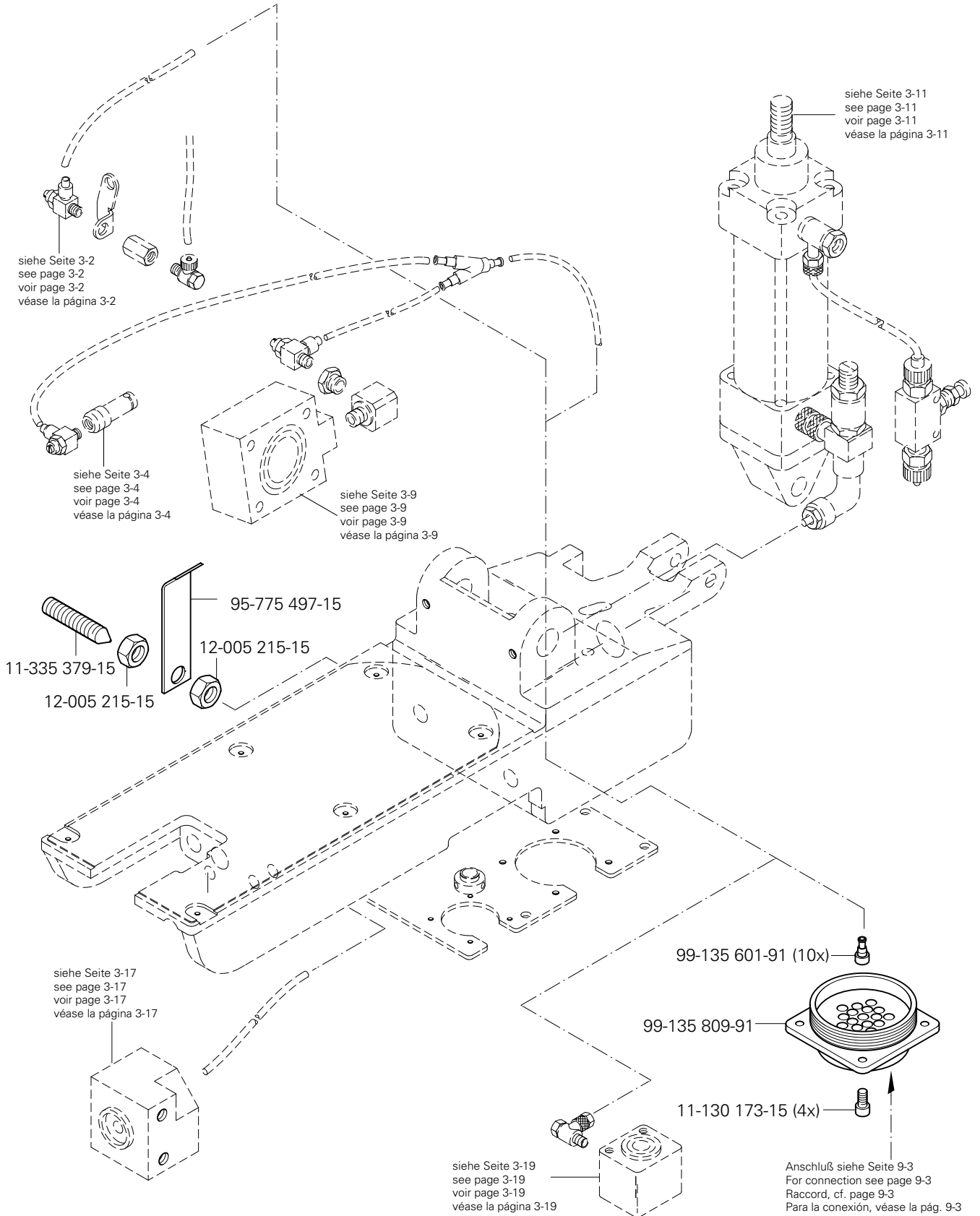

3.04

Grundplattenteile
Bedplate parts
Pièces du plateau fondamental
Piezas del cárter

PFAFF 3588-12/021

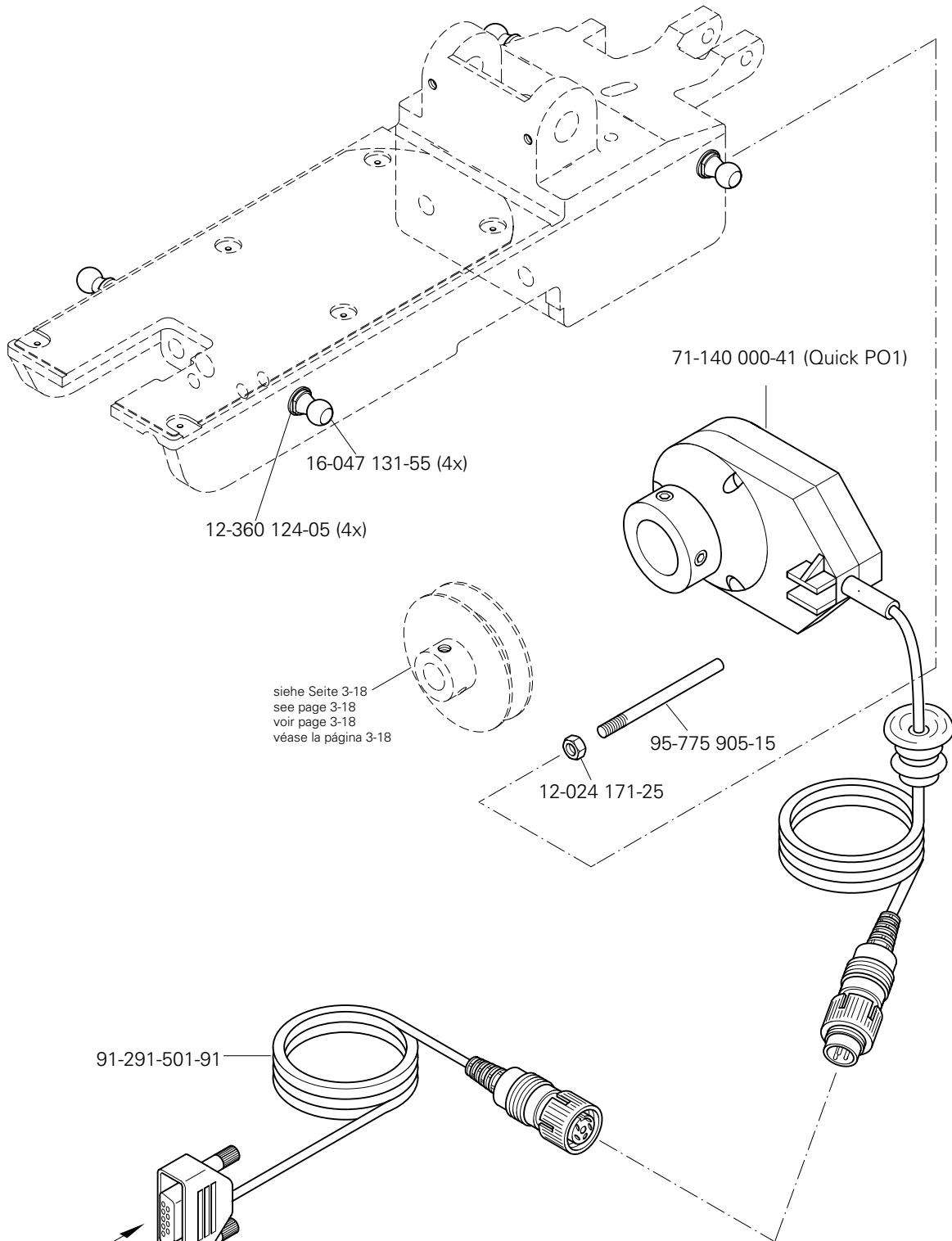
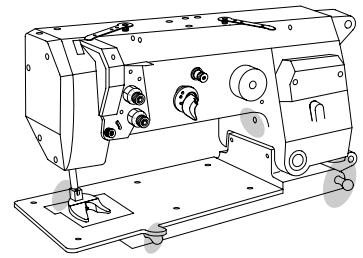

Anschluß siehe Seite 10-9
For connection see page 10-9
Raccord, cf. page 10-9
Para la conexión, véase la pág. 10-9

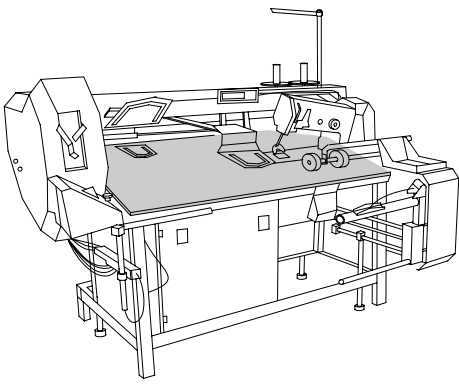

Tischplatte
 Table top
 Plateau de table
 Tablero de costura PFAFF 3588-12/021

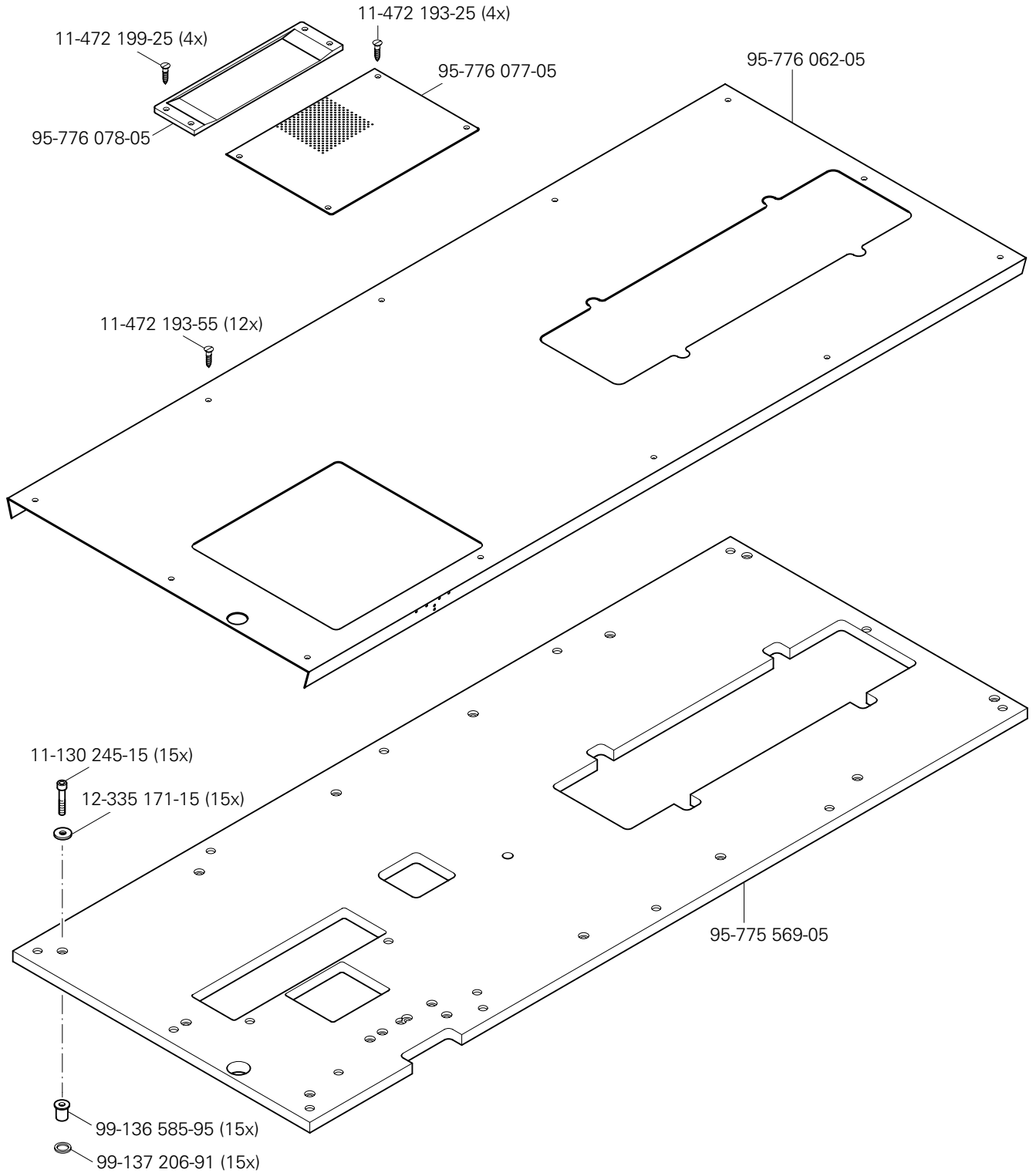

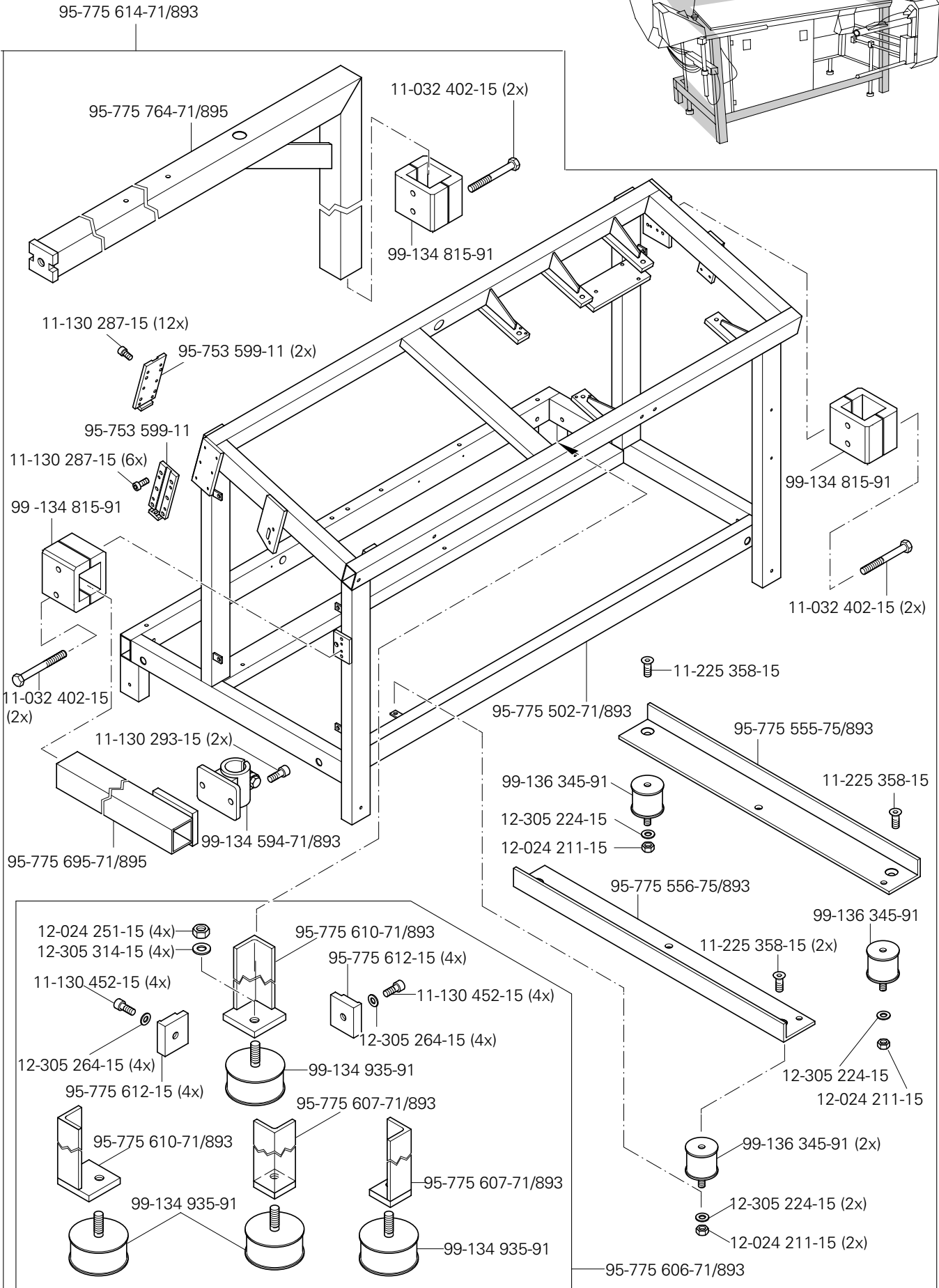
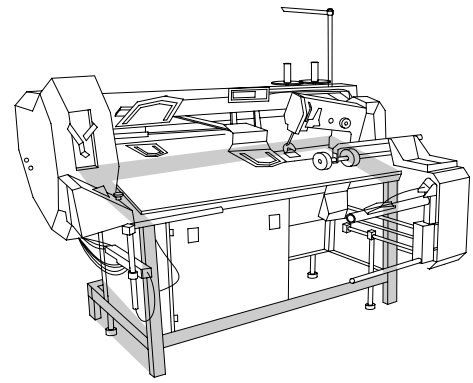

5

Gestell mit Anbauteilen
 Stand with assembly parts
 Bâti avec éléments de montage
 Bancada con piezas de montaje PFAFF 3588-12/021

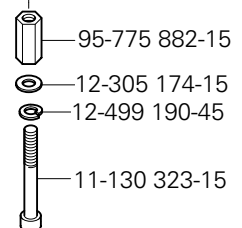
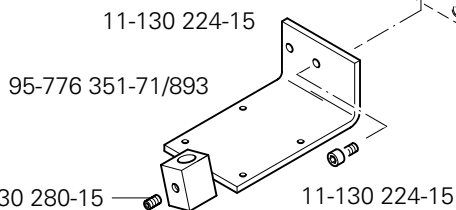
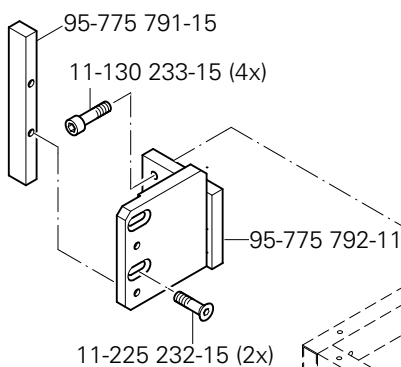
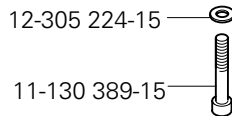
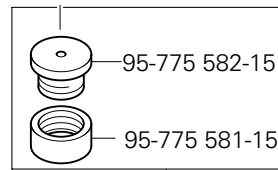
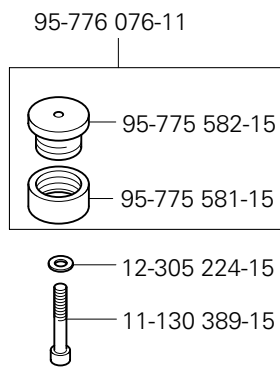
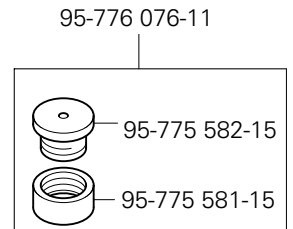
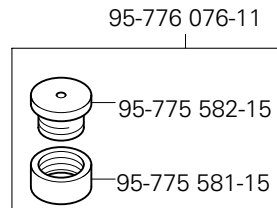
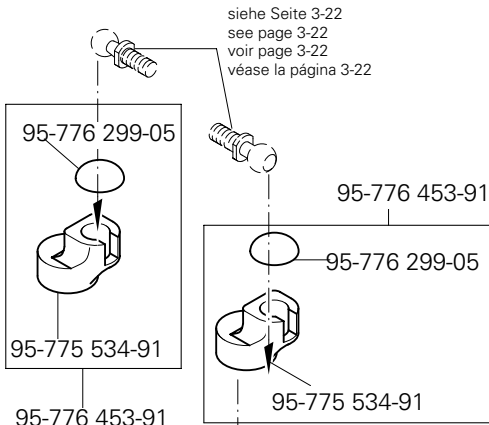
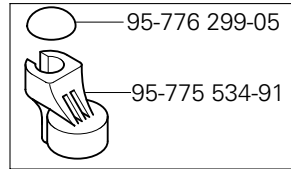
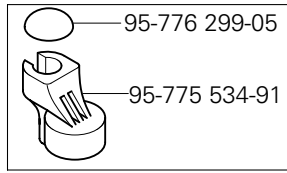
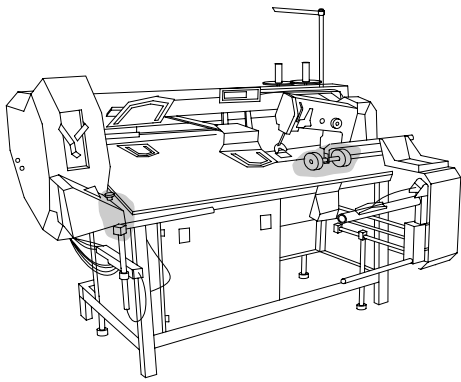

Gestell mit Anbauteilen
 Stand with assembly parts
 Bâti avec éléments de montage
 Bancada con piezas de montaje PFAFF 3588-12/021



 siehe Kapitel 2 Erläuterung der Schlüsselzeichen
 see chapter 2 Explanation of key markings
 voir le chap. 2 Explication des symboles
 véase el Cap. 2 Explicaciones de los signos clave

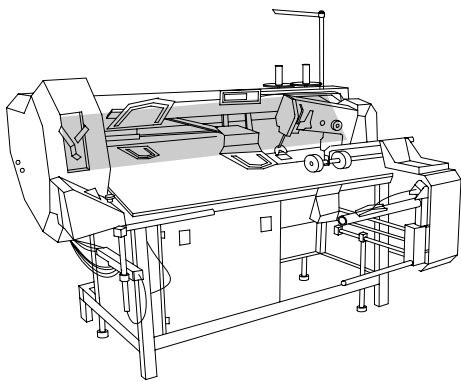

X-Y-Antrieb
 X-Y drive
 Système de commande X-Y
 Grupo de accionamiento "X-Y" PFAFF 3588-12/021

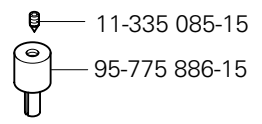
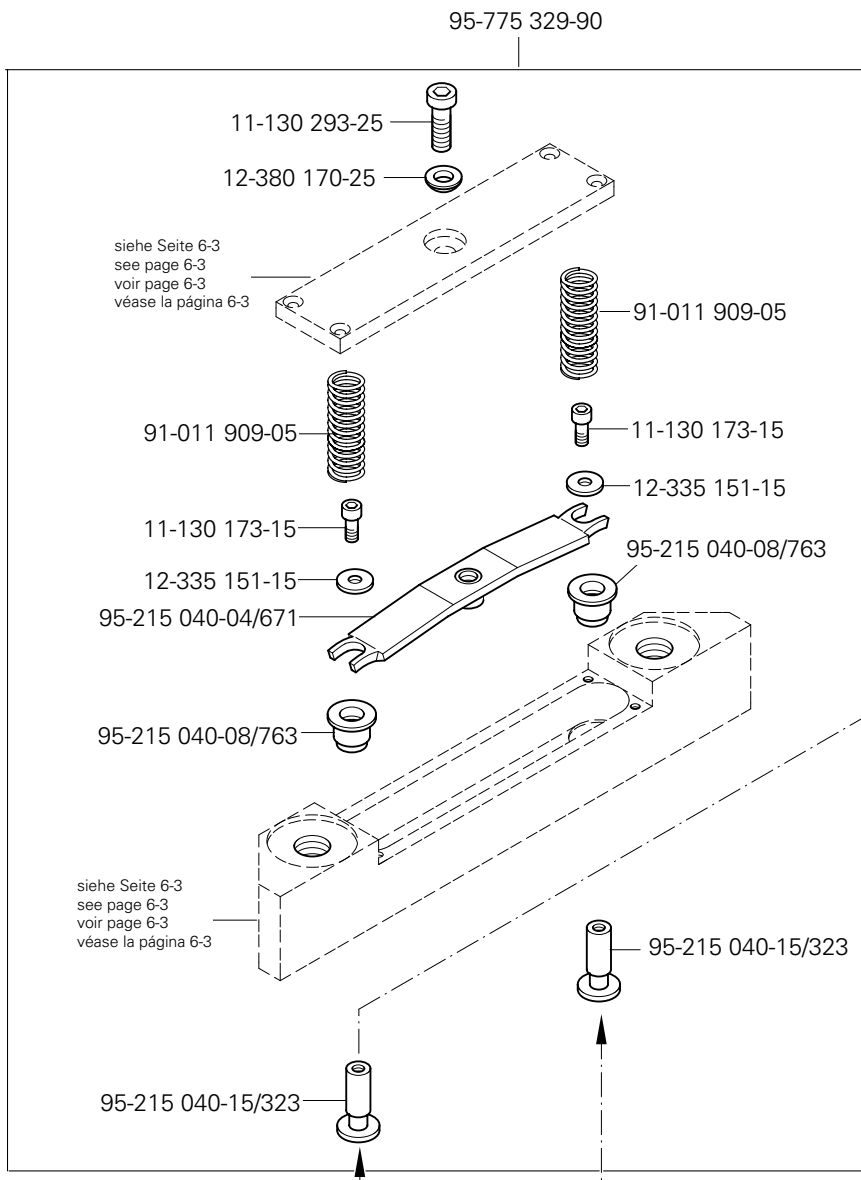
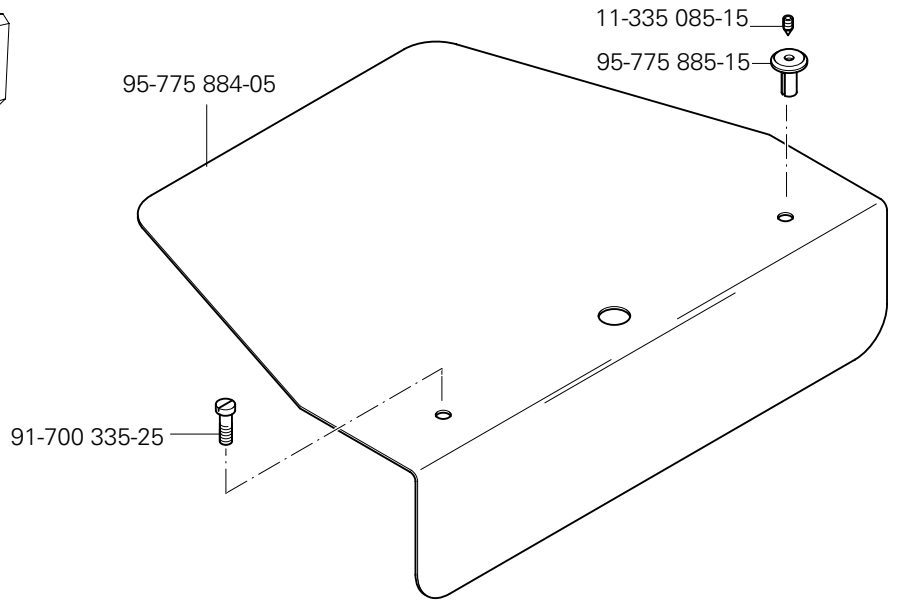

siehe Seite 6-3
 see page 6-3
 voir page 6-3
 véase la página 6-3

siehe Seite 6-3
 see page 6-3
 voir page 6-3
 véase la página 6-3

Anschluß siehe Seite 15-14
 For connection see page 15-14
 Raccord, cf. page 15-14
 Para la conexión, véase la pág. 15-14

☐ siehe Kapitel 2 Erläuterung der Schlüsselzeichen
 see chapter 2 Explanation of key markings
 voir le chap. 2 Explication des symboles
 véase el Cap. 2 Explicaciones de los signos clave

6

X-Y-Antrieb X-Y drive Système de commande X-Y Grupo de accionamiento "X-Y" PFAFF 3588-12/021

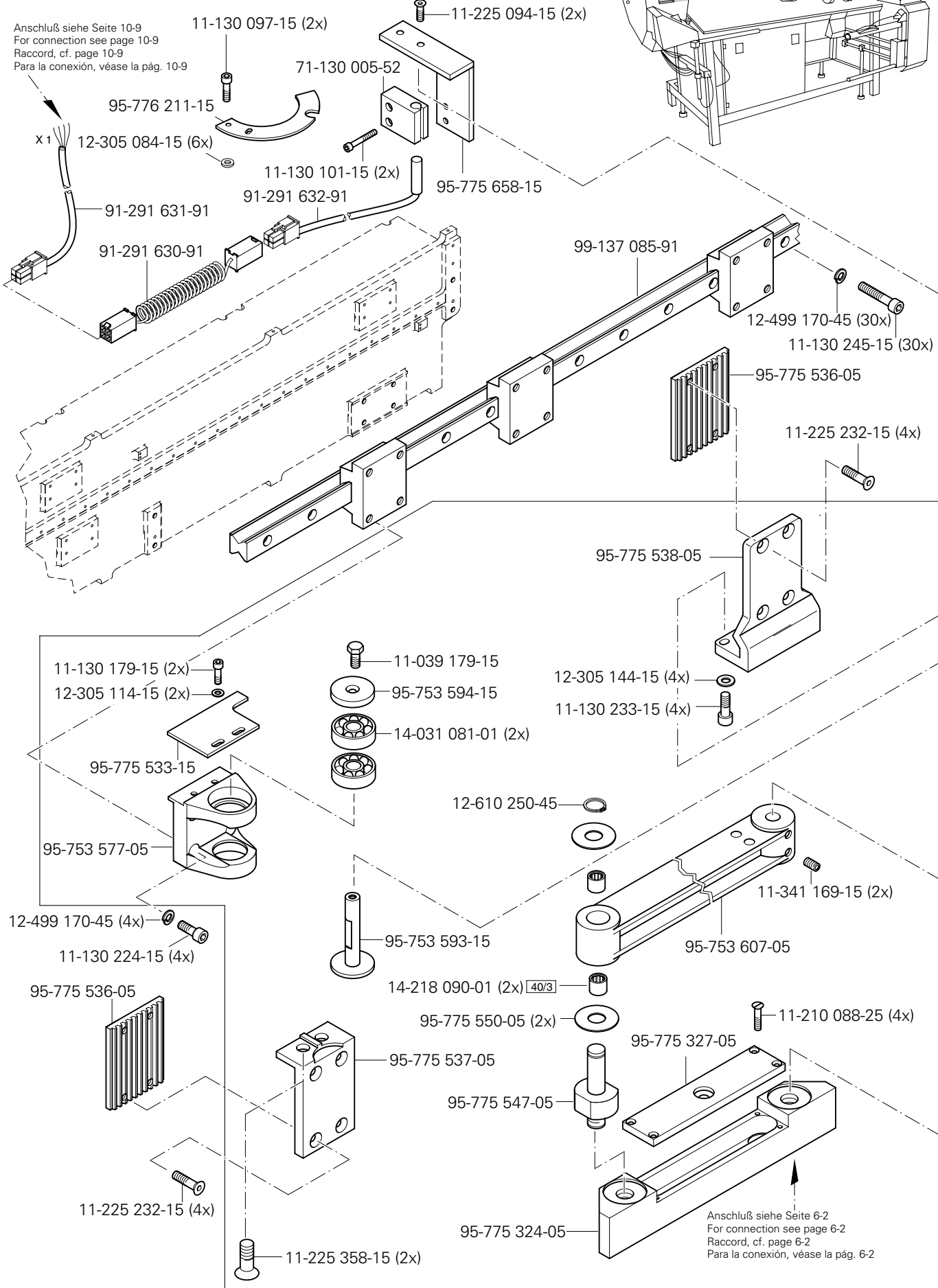

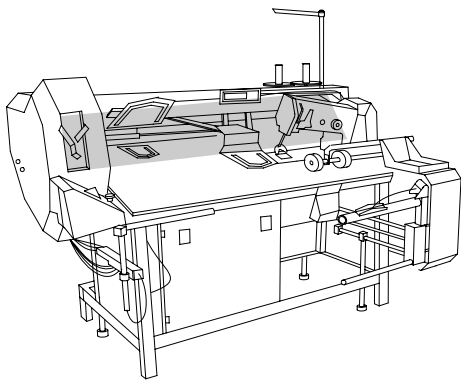

X-Y-Antrieb
 X-Y drive
 Système de commande X-Y
 Grupo de accionamiento "X-Y" PFAFF 3588-12/021

95-775 549-01

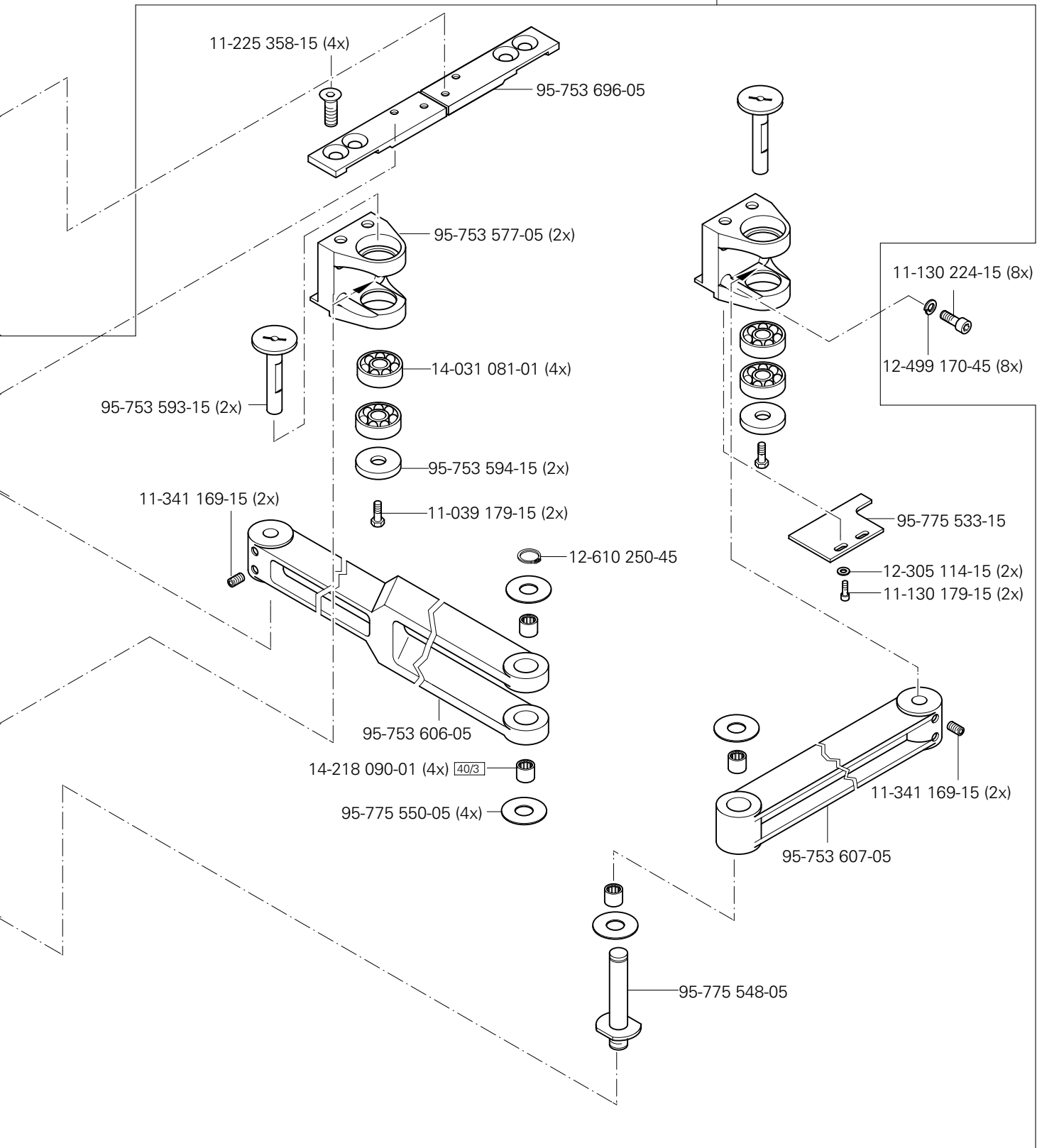

siehe Kapitel 2 Erläuterung der Schlüsselzeichen
 see chapter 2 Explanation of key markings
 voir le chap. 2 Explication des symboles
 véase el Cap. 2 Explicaciones de los signos clave

6

X-Y-Antrieb
 X-Y drive
 Système de commande X-Y
 Grupo de accionamiento "X-Y" PFAFF 3588-12/021

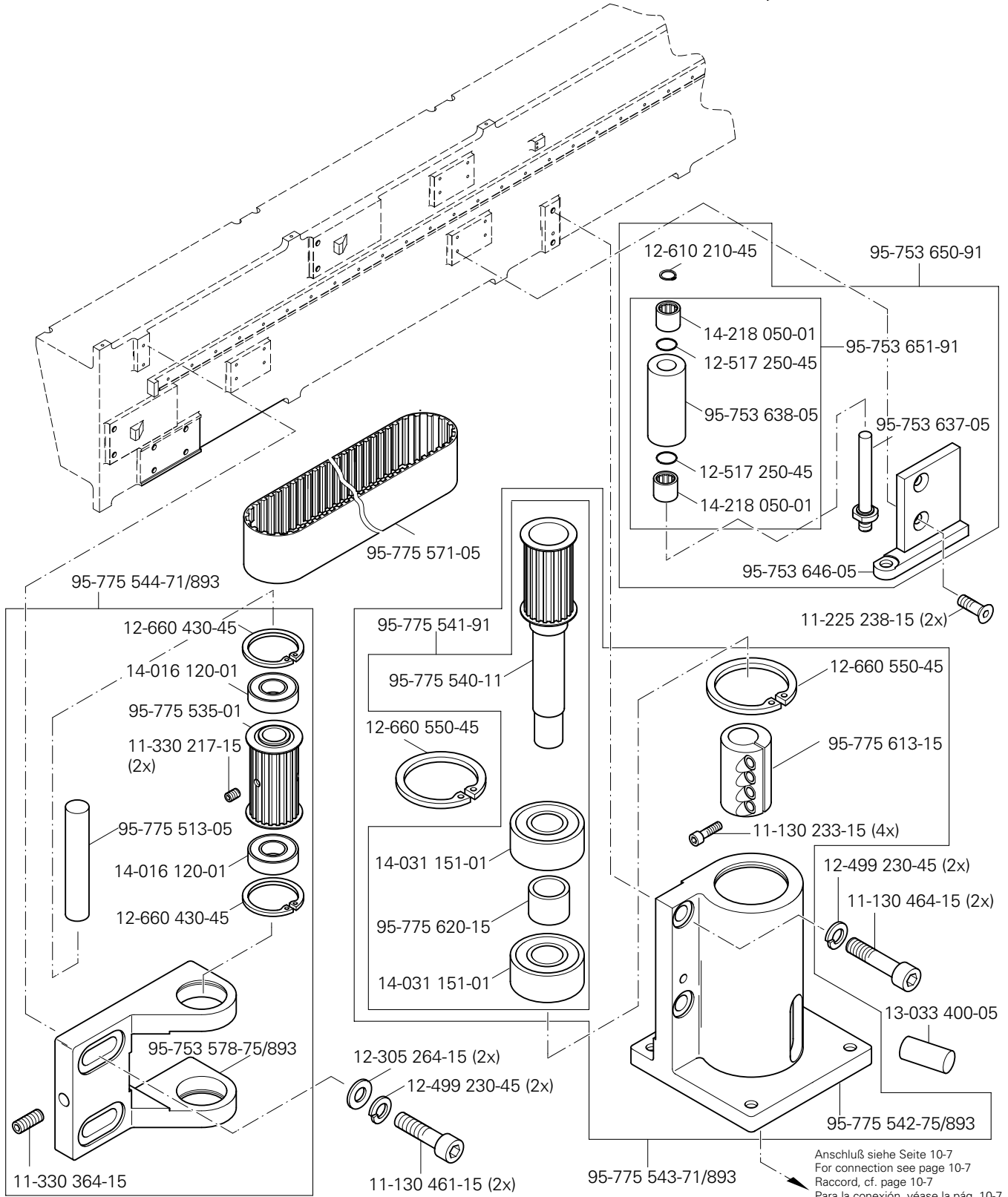
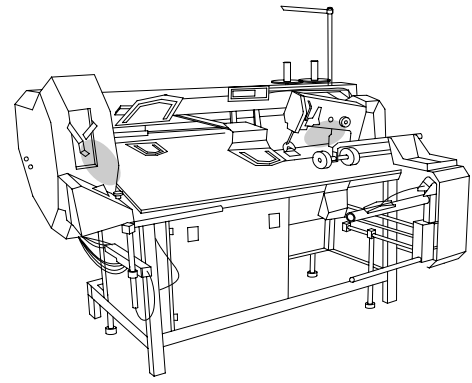

6

X-Y-Antrieb
 X-Y drive
 Système de commande X-Y
 Grupo de accionamiento "X-Y" PFAFF 3588-12/021

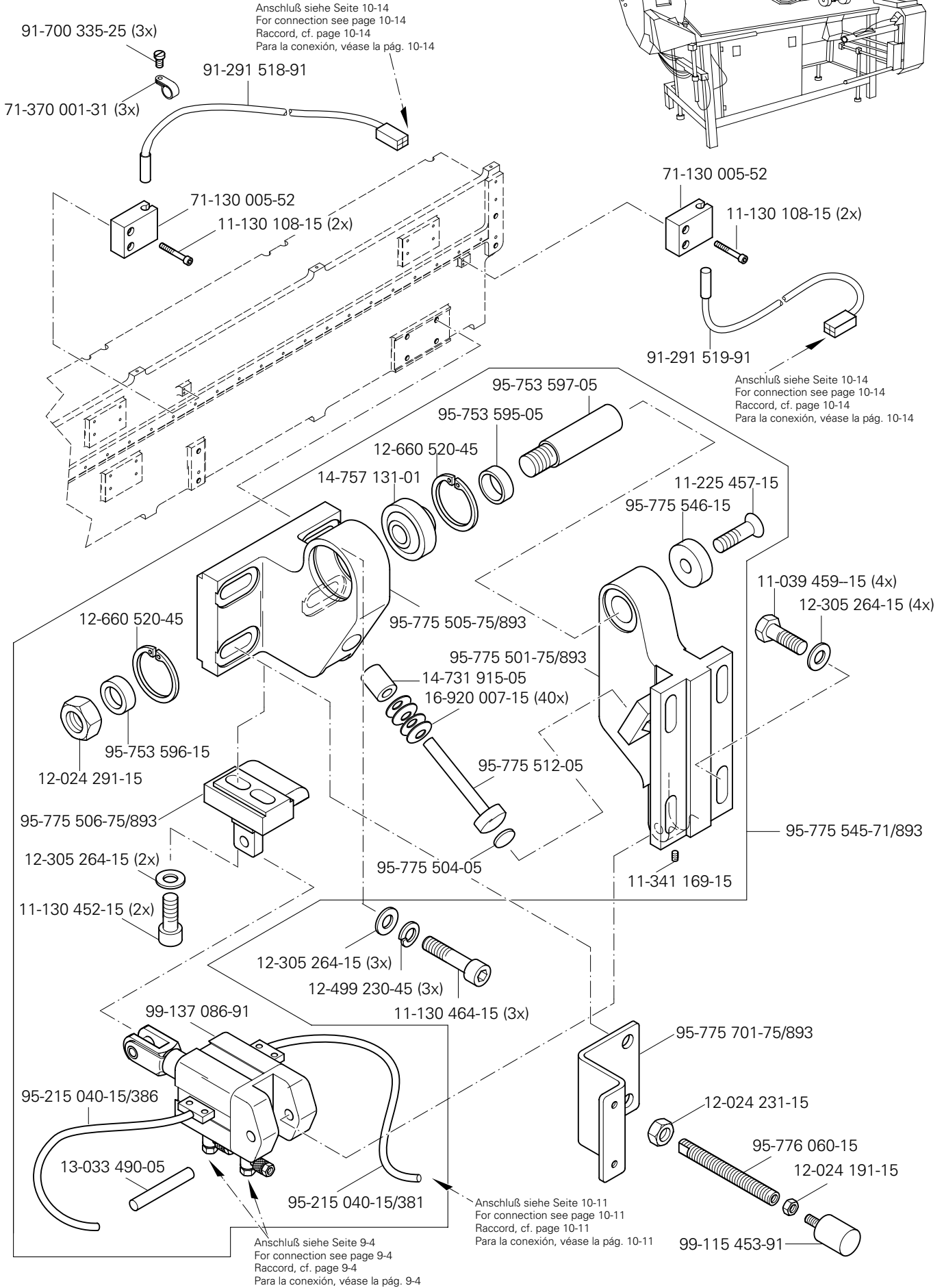
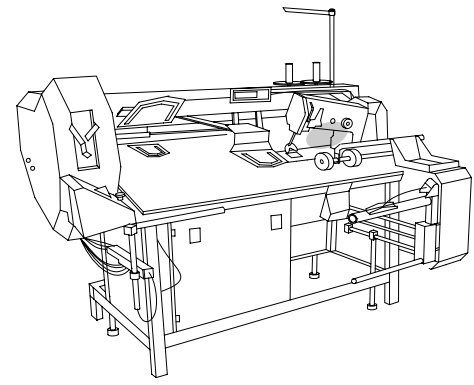

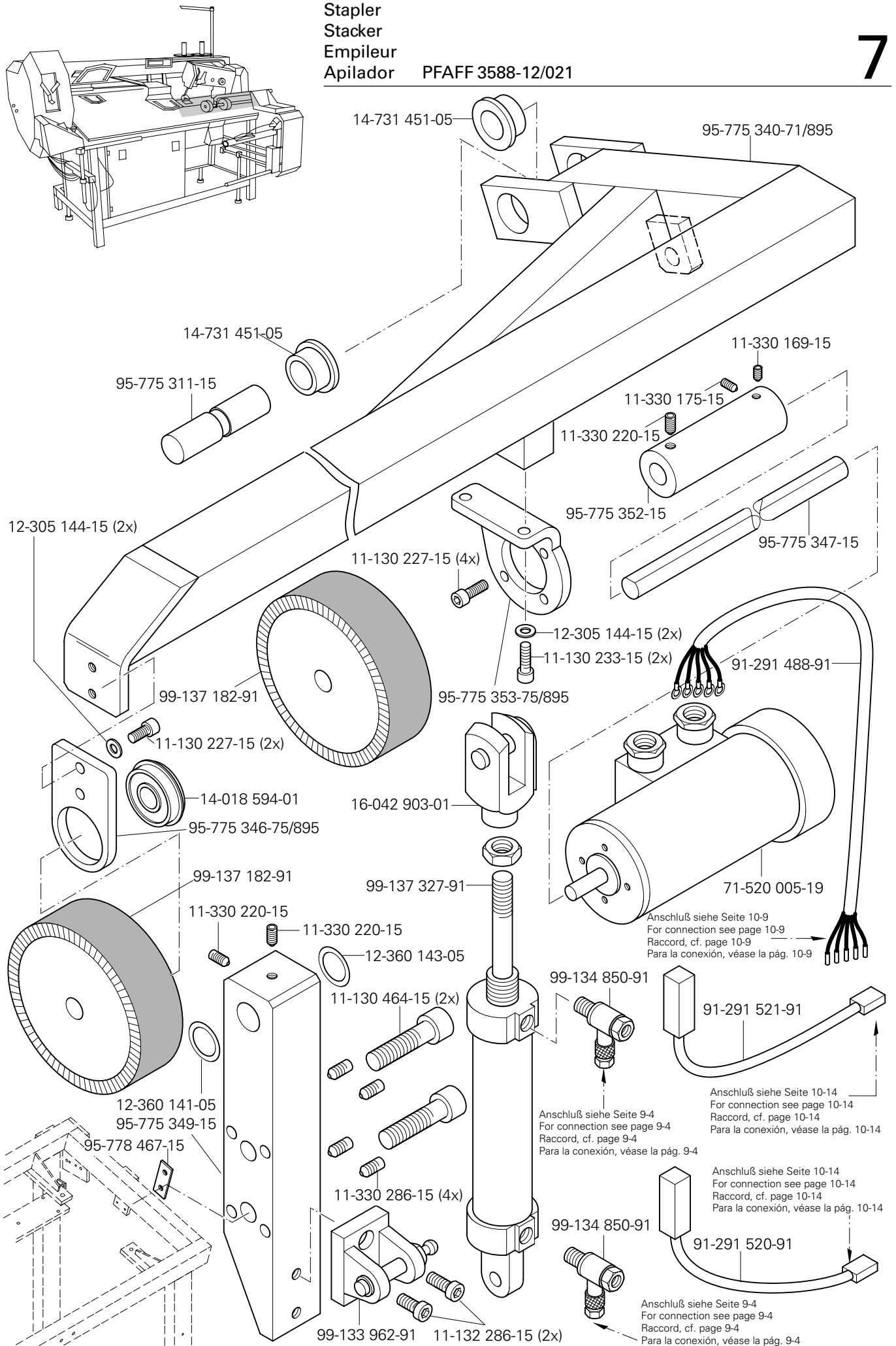

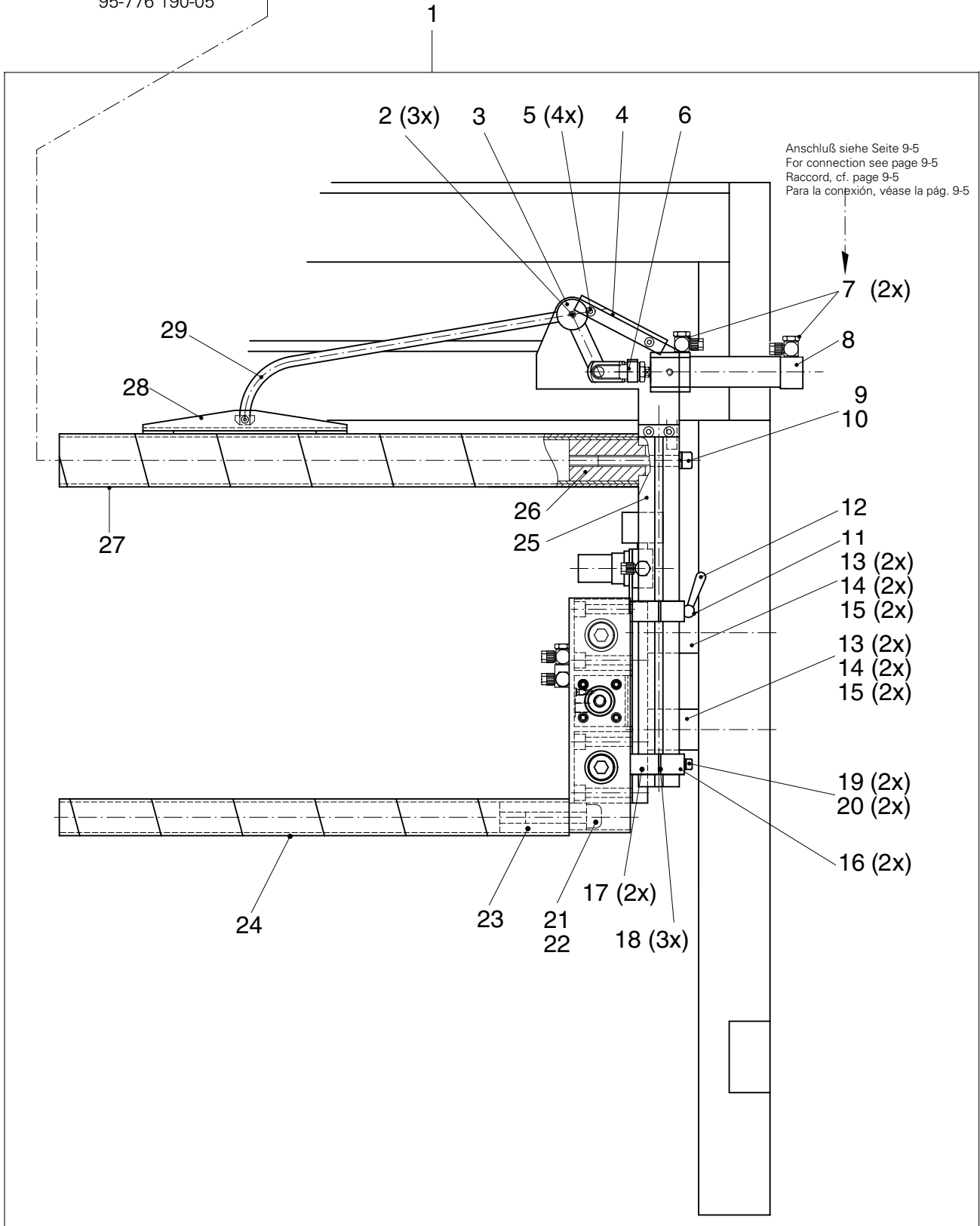
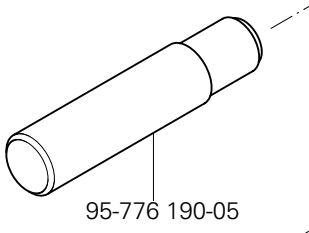
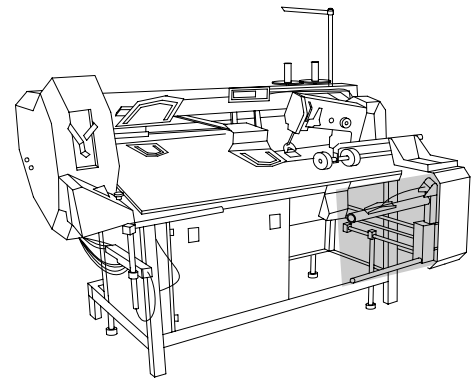

 siehe Kapitel 2 Erläuterung der Schlüsselzeichen
 see chapter 2 Explanation of key markings
 voir le chap. 2 Explication des symboles
 véase el Cap. 2 Explicaciones de los signos clave

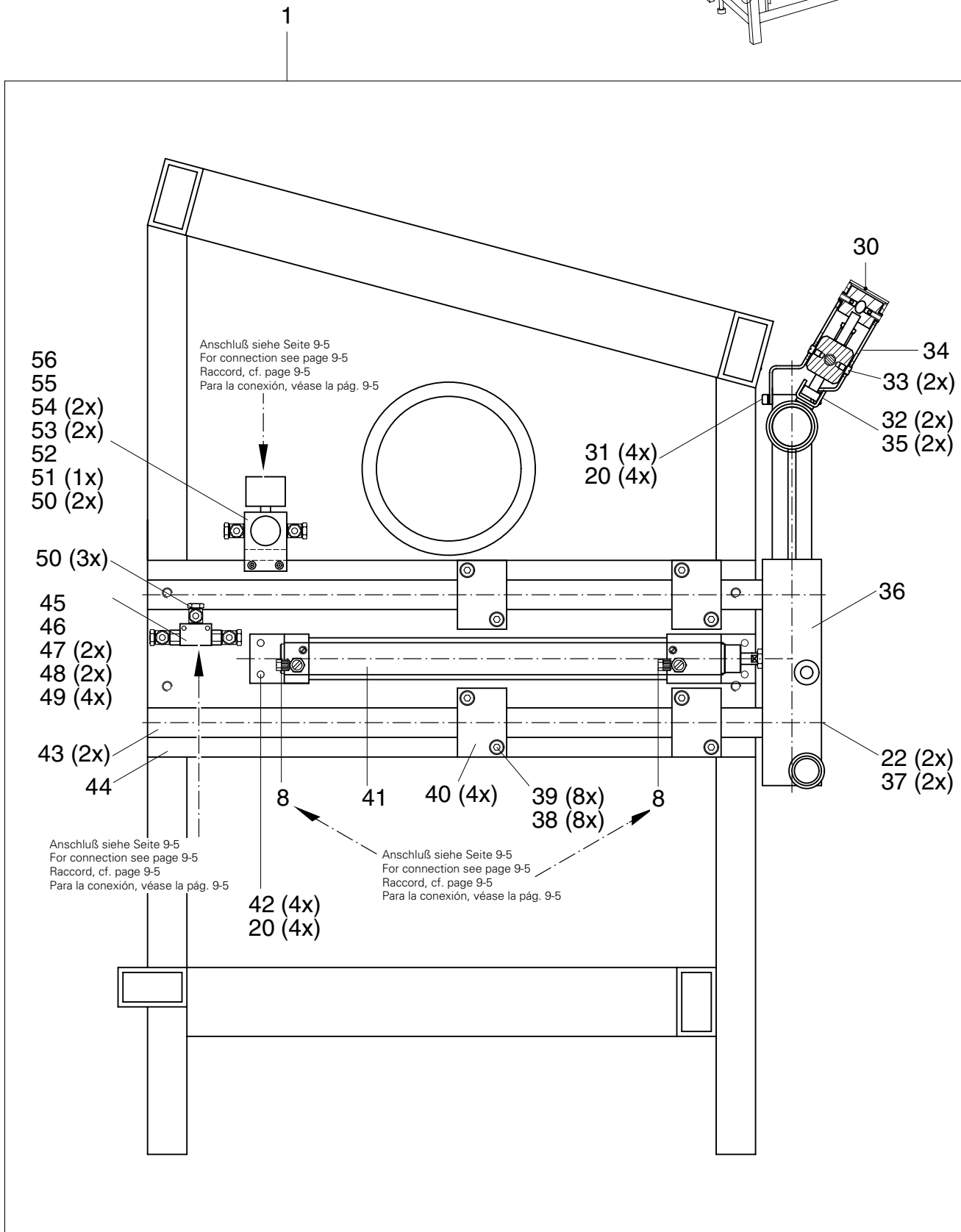
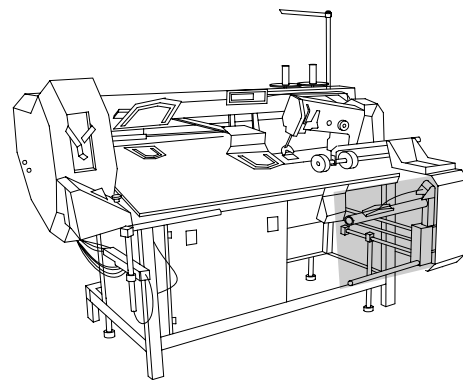

Pos.-Nr. Item No. N° pos. N° de pos.	Bestellnummer Part number N° de commande N° de pedido	Teile-Benennung Description Désignation Denominación	Pos.-Nr. Item No. N° pos. N° de pos.	Bestellnummer Part number N° de commande N° de pedido	Teile-Benennung Description Désignation Denominación
1	95-215 000-03/299	Stapler Stacker Empileur Apilador	17	95-215 040-13/591	Führung 20 x 27 x 60 Guide Guide Guía
2	11-330 280-15	Gewindestift M6 x 8 Threaded stud Vis sans tête Tornillo prisionero	18	95-215 040-14/136	Distanzstück Spacer Pièce d'écartement Pieza distanciadora
3	95-215 040-14/141	Klemmstück Clamping piece Pièce de serrage Pieza presora	19	11-130 332-15	Zylinderschraube M6 x 65 Pan-head screw Vis à tête cylindrique Tornillo cilíndrico
4	95-215 040-13/878	Deckel Cover Couvercle Tapa	20	12-501 190-45	Federring 6 Spring washer Rondelle élastique Arandela elástica
5	11-130 906-15	Zylinderschraube M5 x 6 Pan-head screw Vis à tête cylindrique Tornillo cilíndrico	21	11-130 719-15	Zylinderschraube M16 x 40 Pan-head screw Vis à tête cylindrique Tornillo cilíndrico
6	95-215 000-00/635	Gabelkopf Fork head Fourche Cabeza horquillada	22	12-499 290-45	Federring 16 Spring washer Rondelle élastique Arandela elástica
7	95-215 080-18/008	Drosselrückschlagventil 1/8" Check-return valve Clapet anti-retour avec étranglement Válvula estranguladora de retroceso	23	95-215 040-14/132	Rohrverbindung 27 x 40 Tube connection Raccord de tuyaux Unión de tubos
8	95-215 000-03/992	Zylinder, doppelt wirkend Cylinder, double-acting Vérin à double effet Cilindro de doble efecto	24	95-215 040-13/923	Rohr Tube Tube Tubo
9	11-130 551-15	Zylinderschraube M12 x 40 Pan-head screw Vis à tête cylindrique Tornillo cilíndrico	25	95-215 040-14/134	Klemmstück 40 x 40 x 343 Clamping piece Pièce de serrage Pieza presora
10	95-215 070-05/901	Federring 12 Spring washer Rondelle élastique Arandela elástica	26	95-215 040-14/133	Rohrverbindung 42 x 58 Tube connection Raccord de tuyaux Unión de tubos
11	95-215 040-12/556	Gewindestift M6 x 79 Threaded stud Vis sans tête Tornillo prisionero	27	95-215 040-13/921	Rohr Tube Tube Tubo
12	95-215 080-29/013	Klemmhebel Clamp lever Lévier de serrage Palanca de fricción	28	95-215 040-14/143	Niederhalter Retainer Serre-ouvrage Sujetatelas
13	95-215 040-14/146	Distanzstück Spacer Pièce d'écartement Pieza distanciadora	29	95-215 040-12/561	Schwenkarm Swivel arm Bras oscillant Brazo giratorio
14	11-130 482-15	Zylinderschraube M10 x 70 Pan-head screw Vis à tête cylindrique Tornillo cilíndrico	30	95-215 040-13/877	Blech Plate Tôle Chapa
15	12-501 230-45	Federring 10 Spring washer Rondelle élastique Arandela elástica	31	11-130 293-15	Zylinderschraube M6 x 16 Pan-head screw Vis à tête cylindrique Tornillo cilíndrico
16	95-215 040-13/535	Führung 20 x 24 x 60 Guide Guide Guía	32	11-225 220-15	Senkschraube M5 x 8 Countersunk screw Vis à tête noyée Tornillo a wellanado

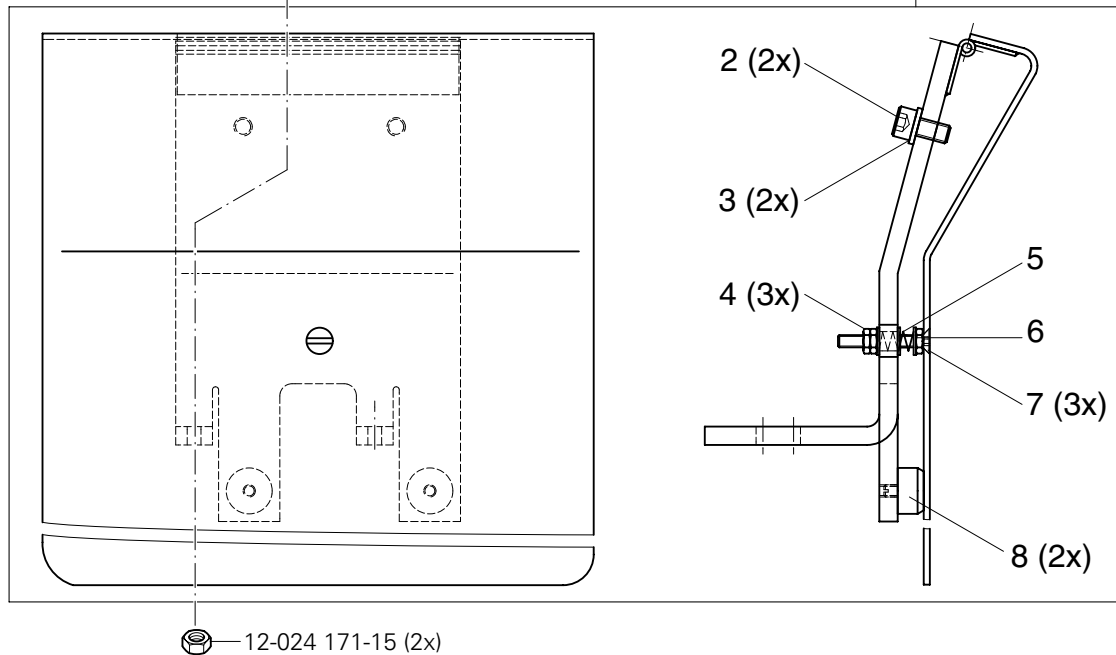
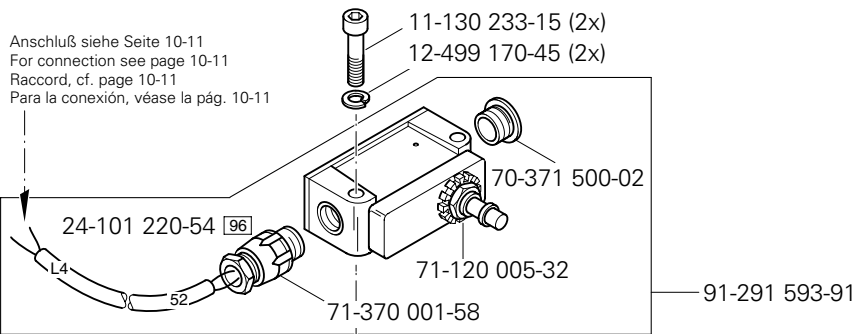
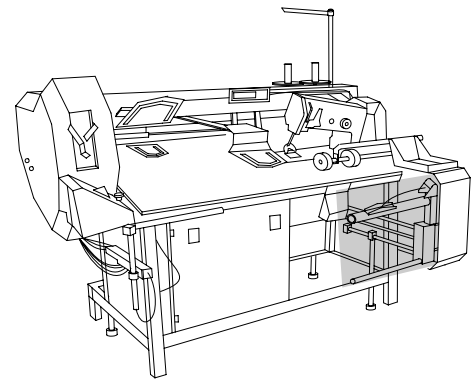

Pos.-Nr. Item No. N° pos. N° de pos.	Bestellnummer Part number N° de commande N° de pedido	Teile-Benennung Description Désignation Denominación	Pos.-Nr. Item No. N° pos. N° de pos.	Bestellnummer Part number N° de commande N° de pedido	Teile-Benennung Description Désignation Denominación
33	95-215 040-18/505	Paßschraube M 6 Shouldered screw Vis de précision Tornillo de ajuste	49	12-501 150-45	Federring 4 Spring washer Rondelle élastique Arandela elástica
34	95-215 040-13/880	Blech Plate Tôle Chapa	50	95-215 080-1 8/102	Schwenkverschraubung Swivel union Raccord pivotant Racora orientable
35	12-505 171-15	Federscheibe B5 Spring washer Rondelle élastique Arandela elástica	51	95-215 080-17/605	Mutter M30 x 1,5 Nut Ecrou Tuerca
36	95-215 040-14/135	Klotz 60 x 230 Block Bloc Bloque	52	95-215 080-17/604	Druckregler Pressure regulator Régulateur de pression Regulador de presión
37	11-130 719-15	Zylinderschraube M16 x 40 Pan-head screw Vis à tête cylindrique Tornillo cilíndrico	53	11-130 227-15	Zylinderschraube M5 x 12 Pan-head screw Vis à tête cylindrique Tornillo cilíndrico
38	12-501 210-45	Federring 8 Spring washer Rondelle élastique Arandela elástica	54	12-501 170-45	Federring 5 Spring washer Rondelle élastique Arandela elástica
39	11-130 395-15	Zylinderschraube M8 x 60 Pan-head screw Vis à tête cylindrique Tornillo cilíndrico	55	95-215 040-15/131	Befestigungsblech Mounting plate Plaque de montage Placa de fijación
40	95-215 040-13/534	Führung Guide Guide Guía	56	95-215 080-23/601	Verschlusschraube G 1/8 Screw plug Vis d'obturation Tornillo de cierre
41	95-215 000-03/413	Zylinder, doppelt wirkend Cylinder, double-acting Vérin à double effet Cilindro de doble efecto			
42	11-130 299-15	Zylinderschraube M6 x 20 Pan-head screw Vis à tête cylindrique Tornillo cilíndrico			
43	95-215 040-12/569	Führungsstange Guide bar Barre de guidage Barra-guía			
44	95-215 040-14/138	Grundplatte Baseplate Plaque fondamentale Placa base			
45	95-215 080-14/925	Doppelrückschlagventil G1/8 Double-check valve Double valve d'arrêt Doble válvula de retención			
46	95-215 040-14/161	Distanzklotz Spacing block Bloc d'écartement Taco distanciador			
47	11-130 179-15	Zylinderschraube M4 x 12 Pan-head screw Vis à tête cylindrique Tornillo cilíndrico			
48	11-130 191-15	Zylinderschraube M4 x 20 Pan-head screw Vis à tête cylindrique Tornillo cilíndrico			



Pos.-Nr. Item No. N° pos. N° de pos.	Bestellnummer Part number N° de commande N° de pedido	Teile-Benennung Description Désignation Denominación	Pos.-Nr. Item No. N° pos. N° de pos.	Bestellnummer Part number N° de commande N° de pedido	Teile-Benennung Description Désignation Denominación
1	95-775 644-71/895	Träger vollst. Bracket assy. Support complet Soporte completo	5	91-022 116-05	Druckfeder Pressure spring Ressort de pression Muelle de presión
2	11-130 287-15	Zylinderschraube M6 x 12 Pan-head screw Vis à tête cylindrique Tornillo cilíndrico	6	11-225 196-15	Senkschraube M4 x 25 Countersunk screw Vis à tête noyée Tornillo avellanado
3	12-305 174-15	Scheibe 6,4 Washer Rondelle Arandela	7	12-305 114-15	Scheibe 4,3 Washer Rondelle Arandela
4	12-024 151-15	Sechskantmutter M4 Hexagon nut Ecrou à six pans Tuerca hexagonal	8	91-024 554-05	Anschlag Stop Butée Tope

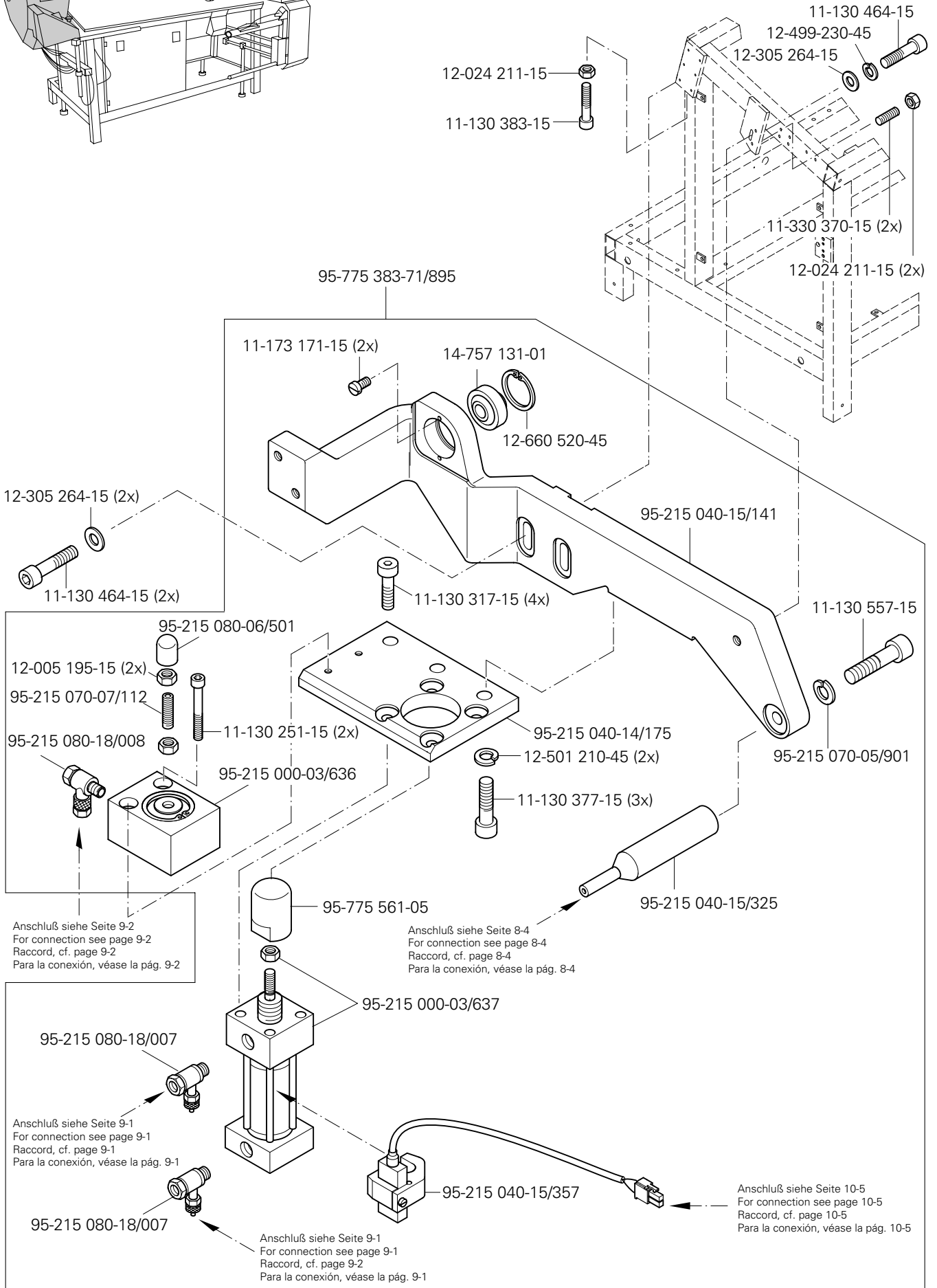
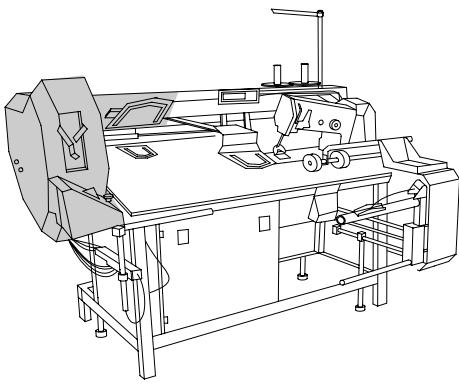

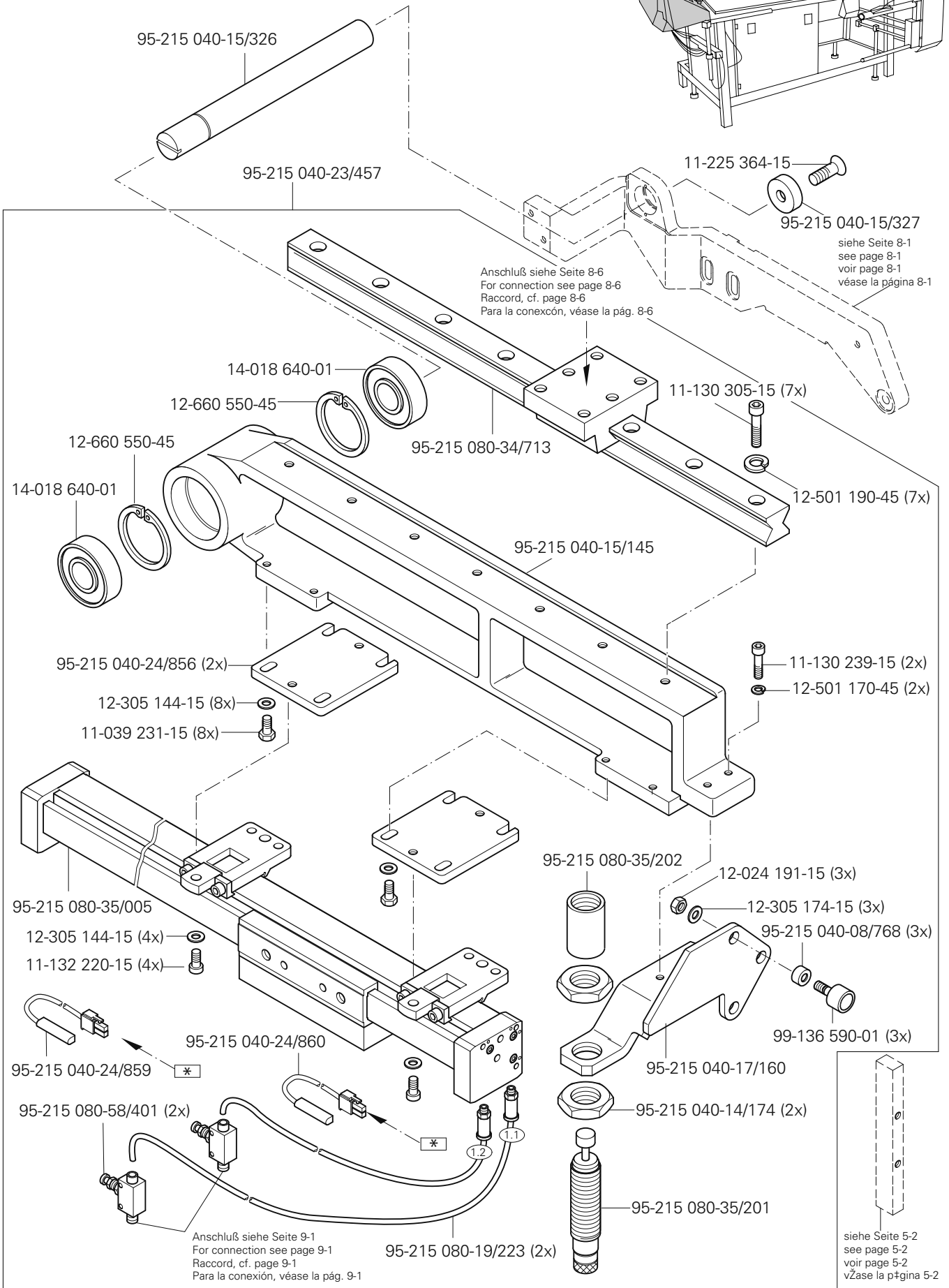
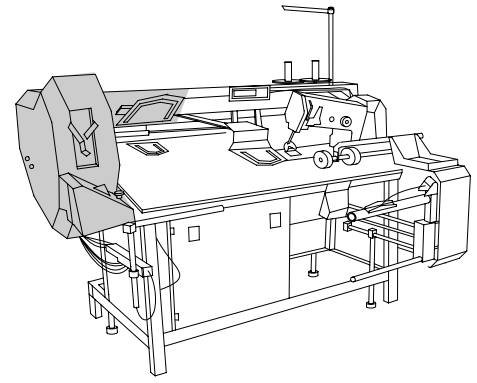

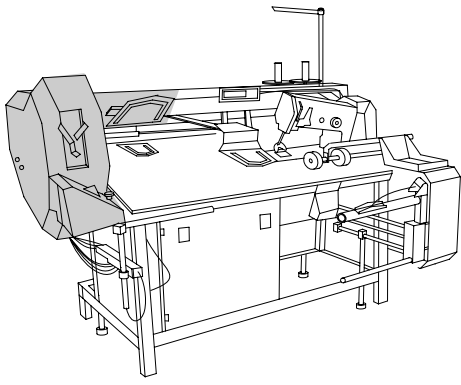

Umbugger
Folder
Remplieur
Grupo doblador PFAFF 3588-12/021

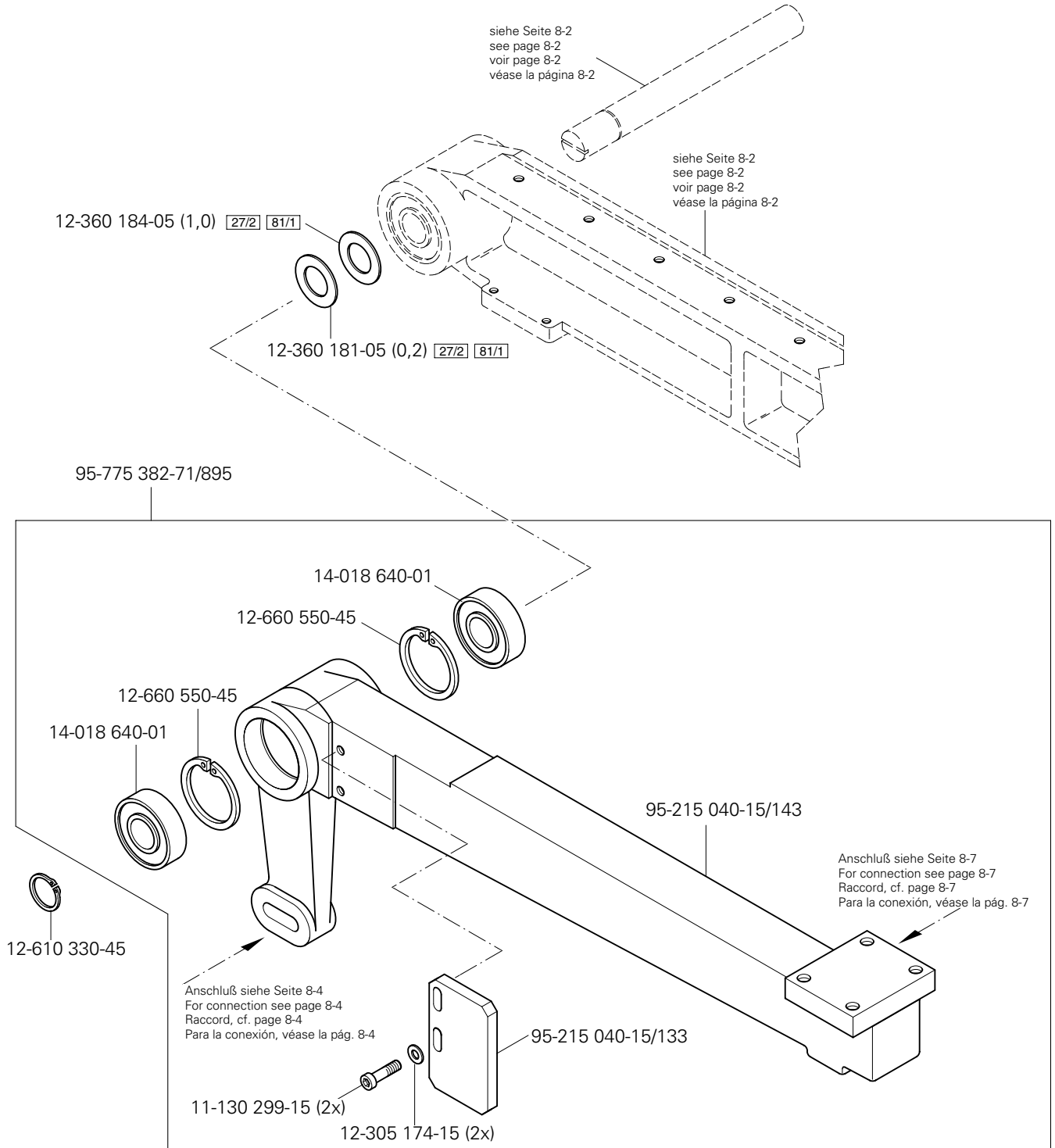

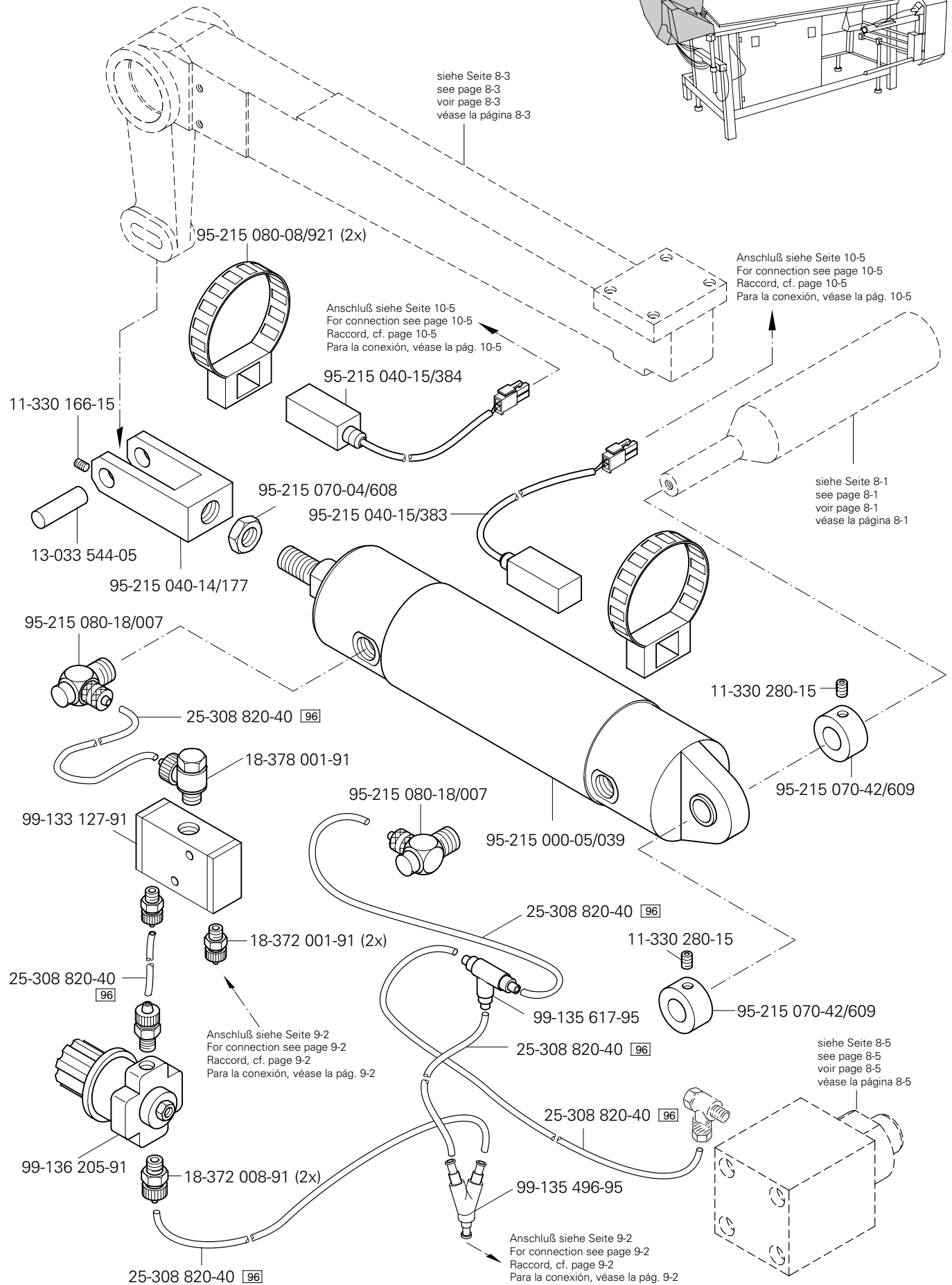
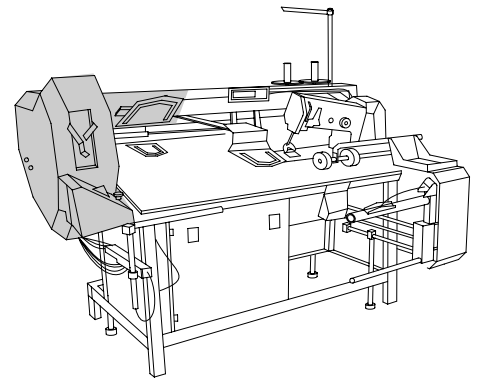

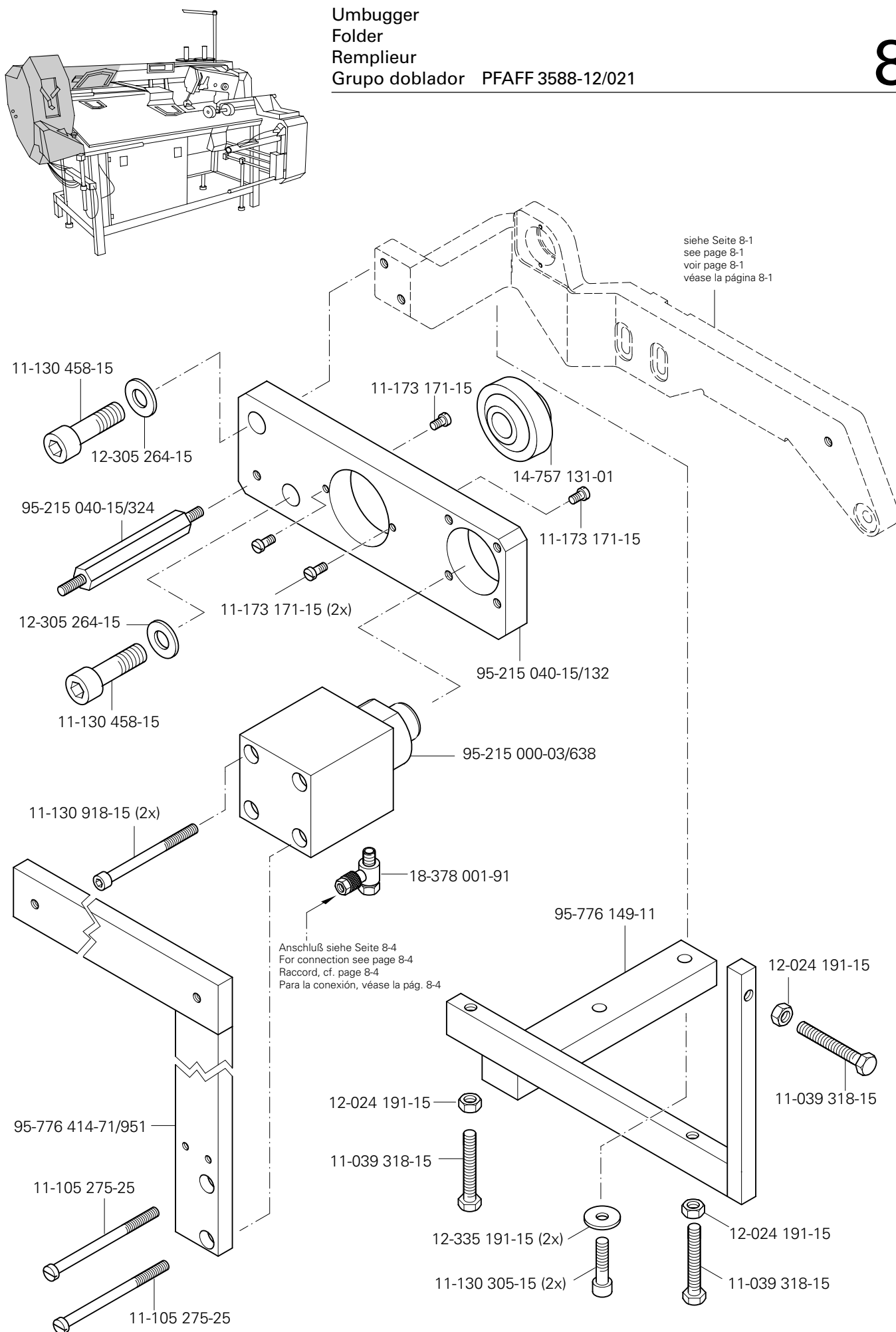

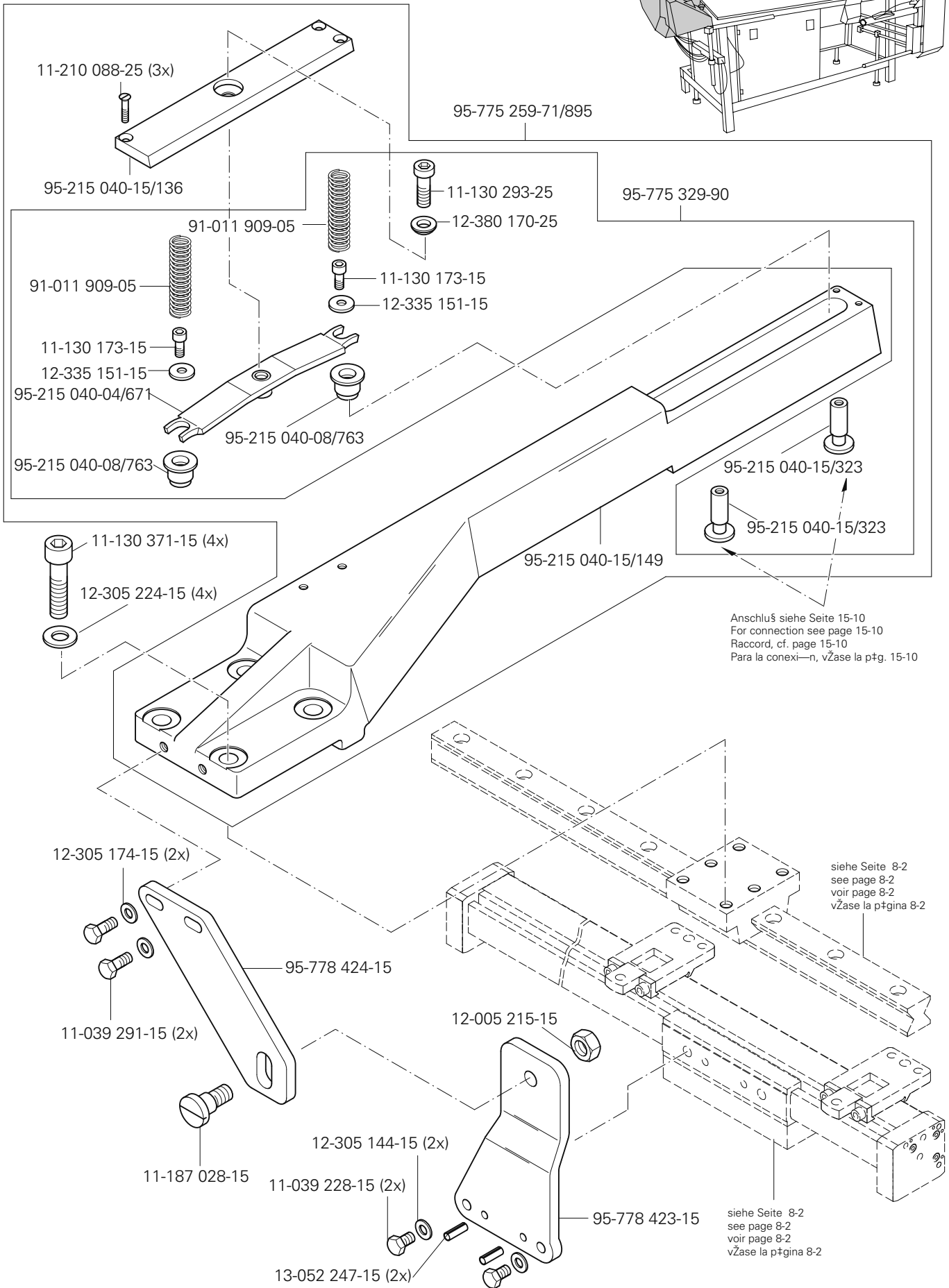
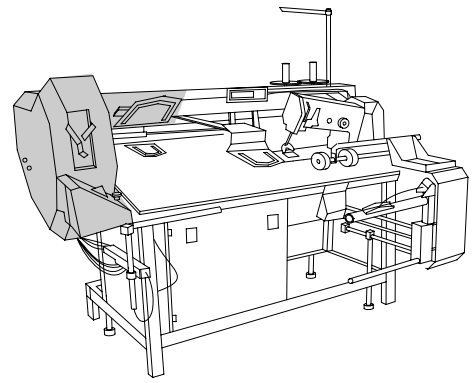

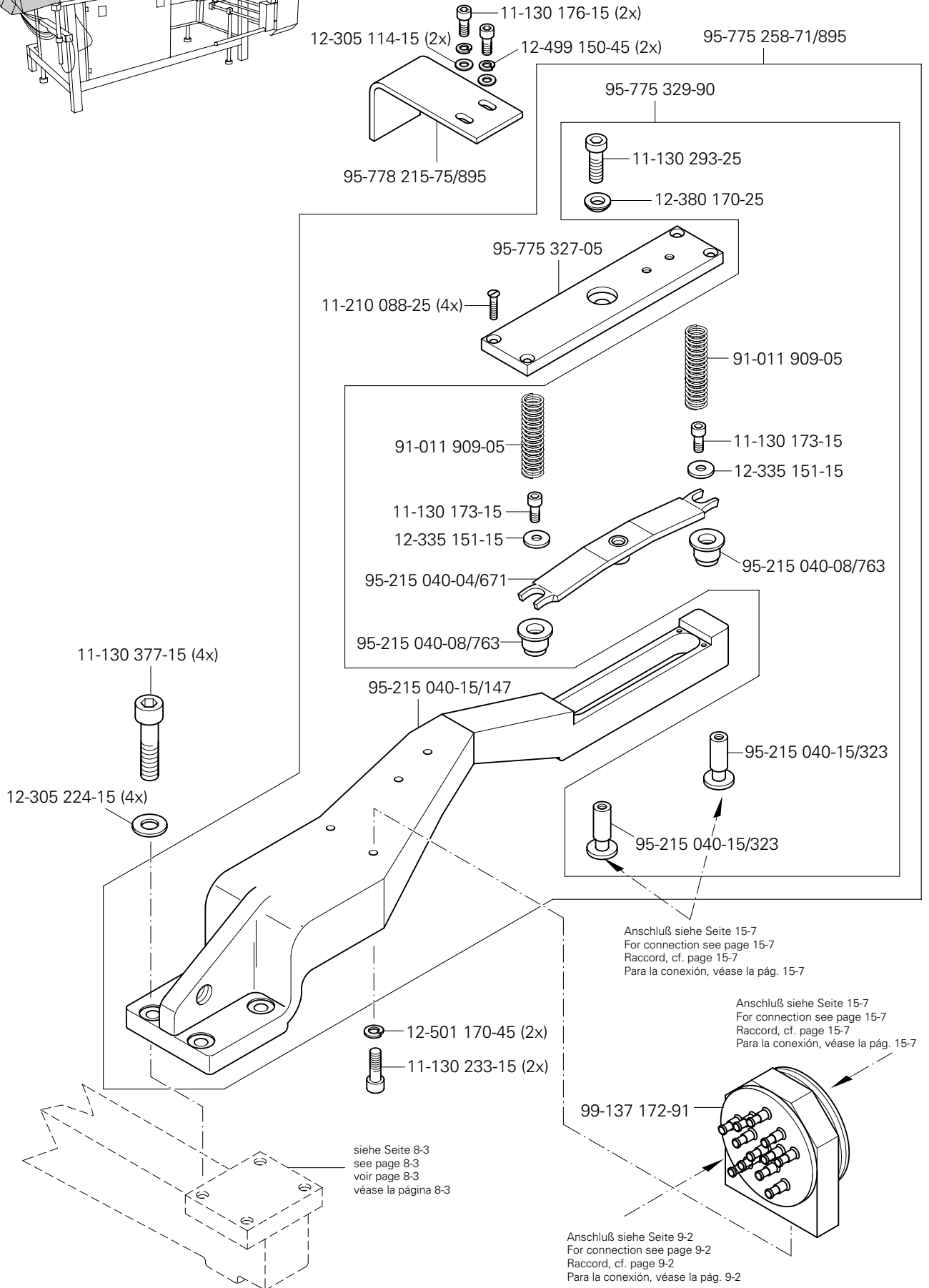
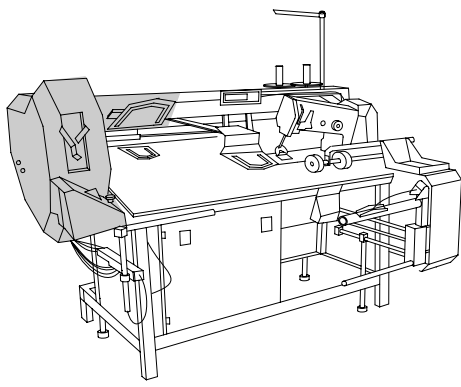

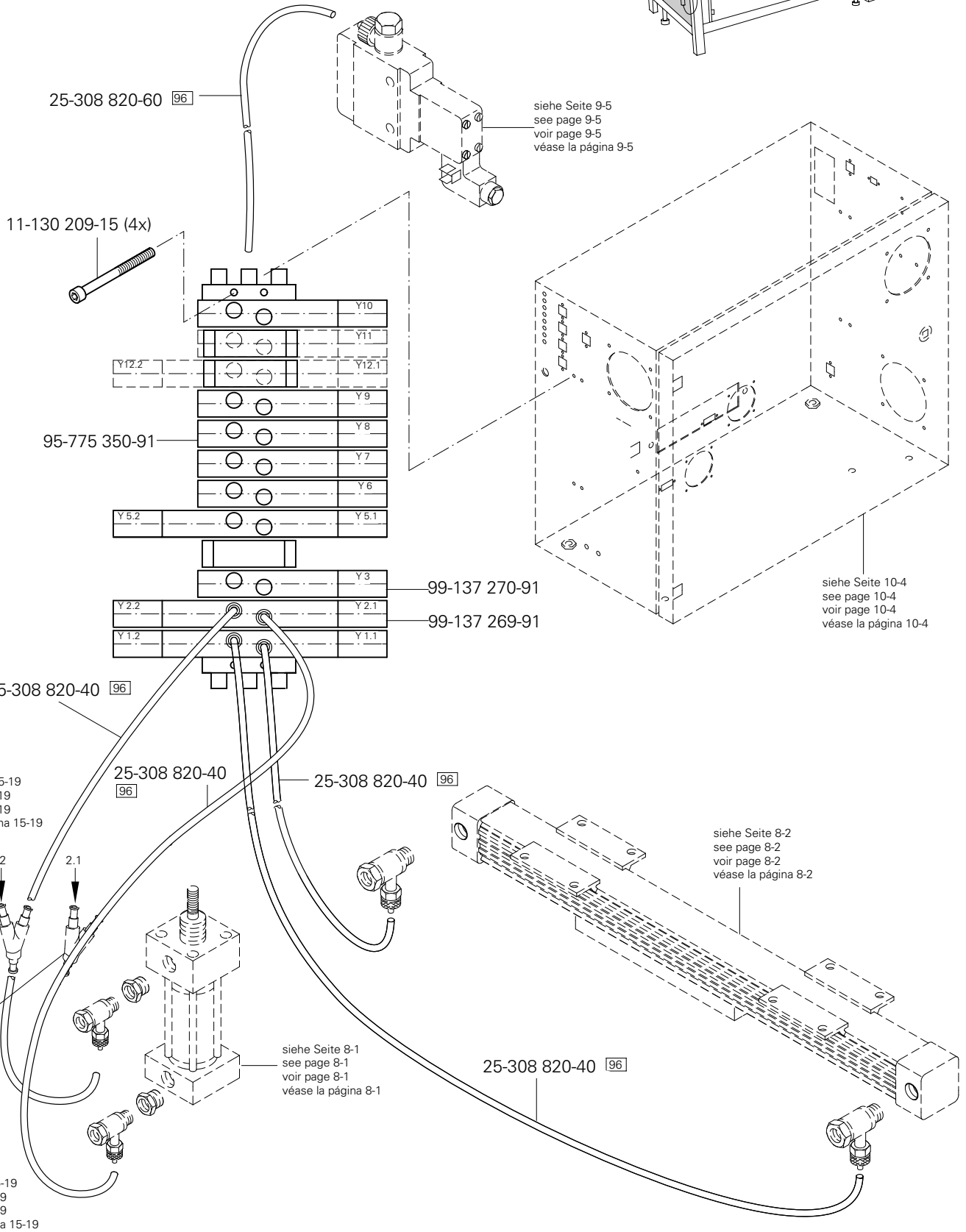
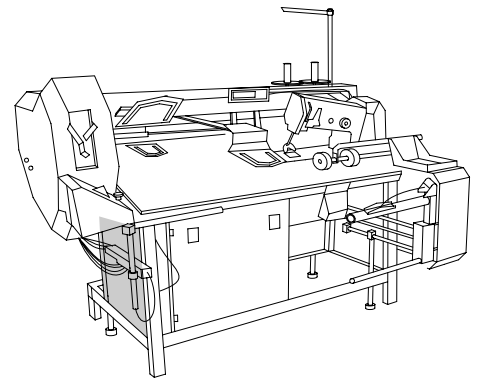

siehe Seite 9-5
 see page 9-5
 voir page 9-5
 véase la página 9-5

siehe Seite 10-4
 see page 10-4
 voir page 10-4
 véase la página 10-4

siehe Seite 8-2
 see page 8-2
 voir page 8-2
 véase la página 8-2

siehe Seite 8-1
 see page 8-1
 voir page 8-1
 véase la página 8-1

siehe Seite 15-19
 see page 15-19
 voir page 15-19
 véase la página 15-19

siehe Seite 15-19
 see page 15-19
 voir page 15-19
 véase la página 15-19

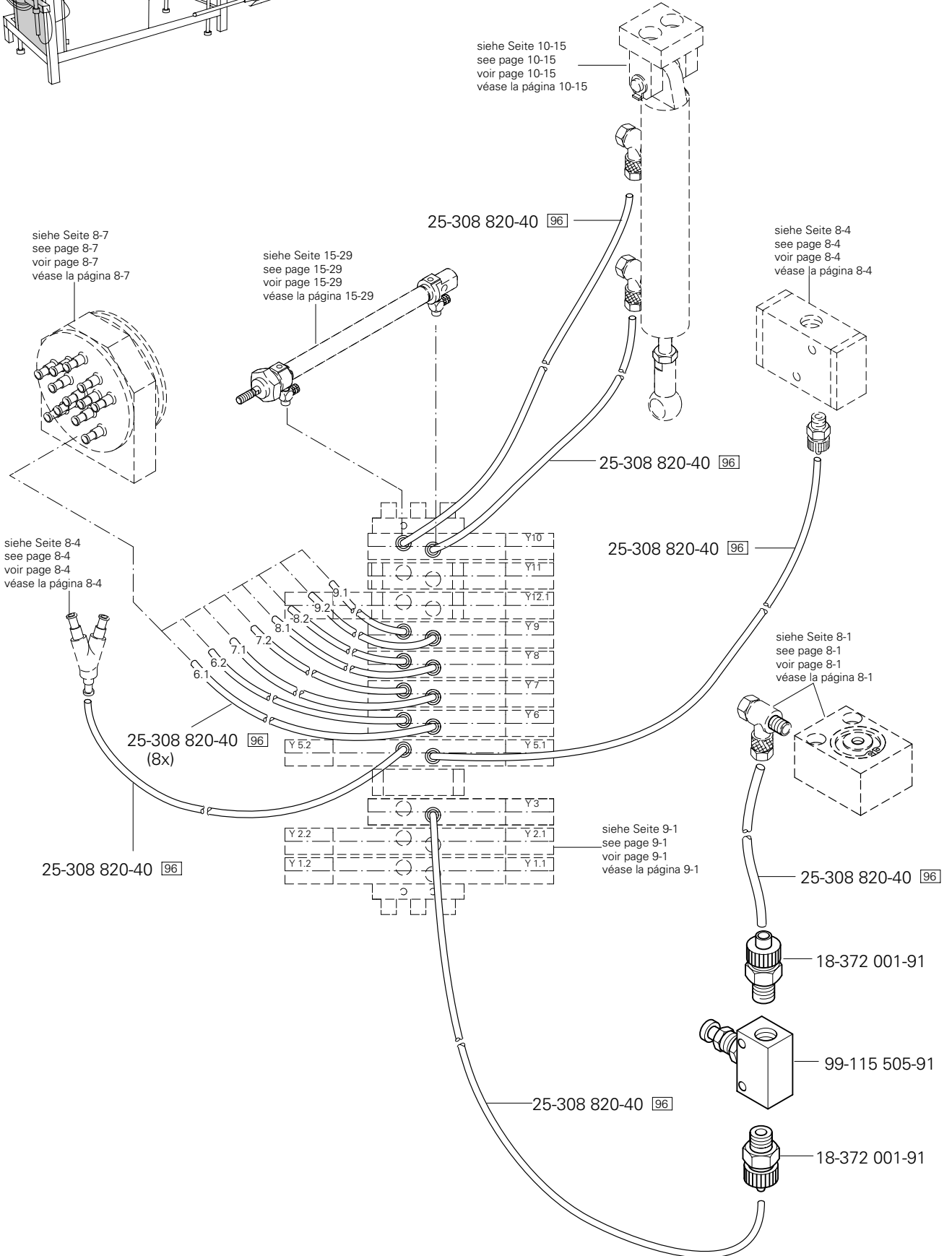
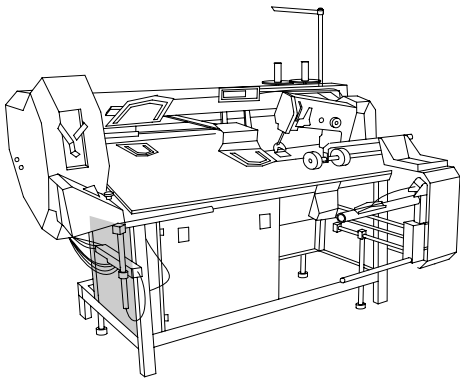

siehe Seite 8-7
 see page 8-7
 voir page 8-7
 véase la página 8-7

siehe Seite 15-29
 see page 15-29
 voir page 15-29
 véase la página 15-29

siehe Seite 10-15
 see page 10-15
 voir page 10-15
 véase la página 10-15

siehe Seite 8-4
 see page 8-4
 voir page 8-4
 véase la página 8-4

siehe Seite 8-4
 see page 8-4
 voir page 8-4
 véase la página 8-4

siehe Seite 8-1
 see page 8-1
 voir page 8-1
 véase la página 8-1

siehe Seite 9-1
 see page 9-1
 voir page 9-1
 véase la página 9-1

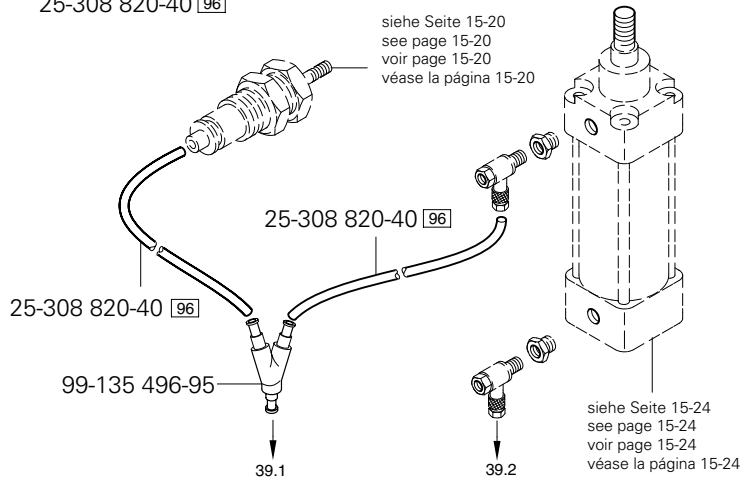
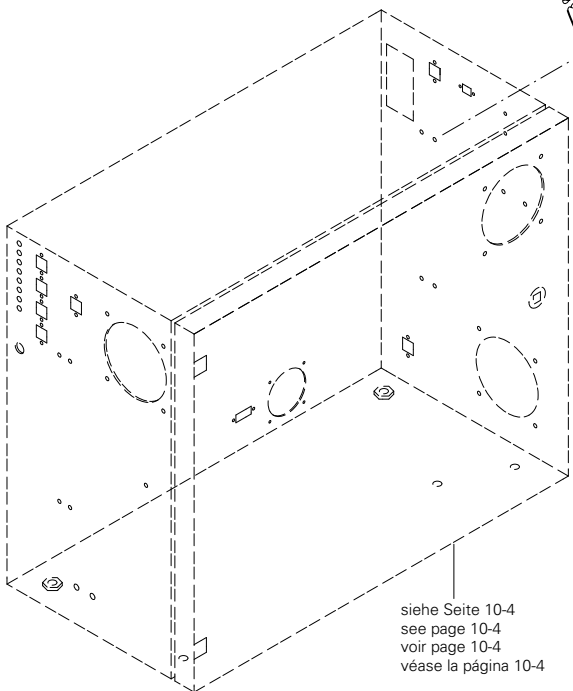
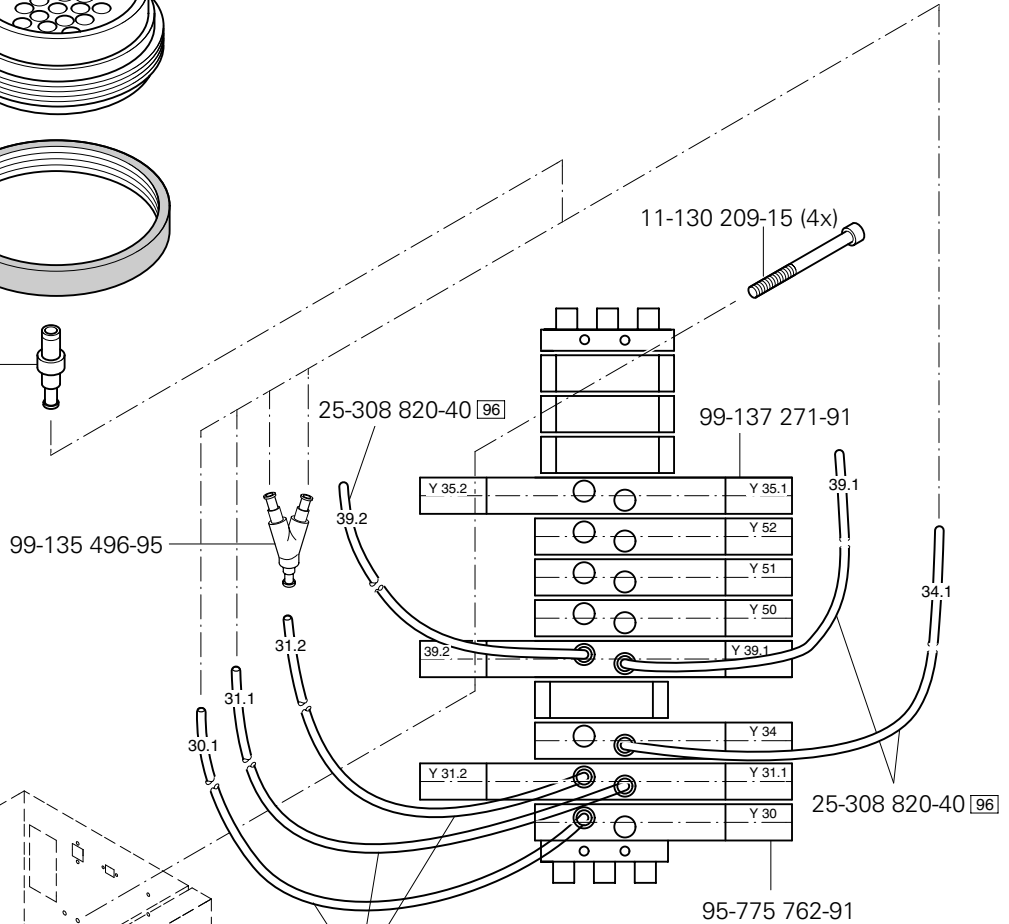
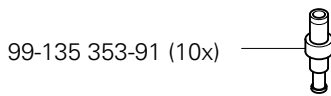
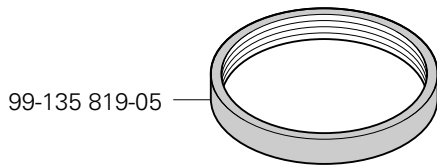
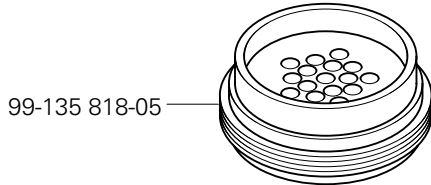
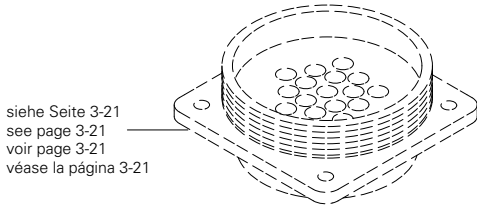
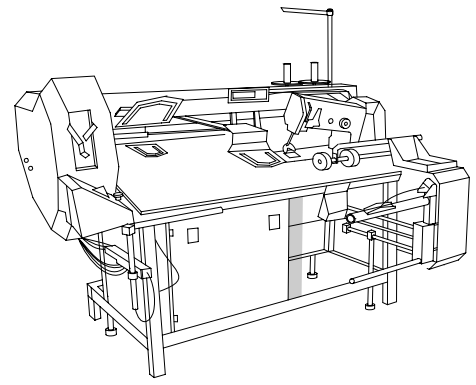

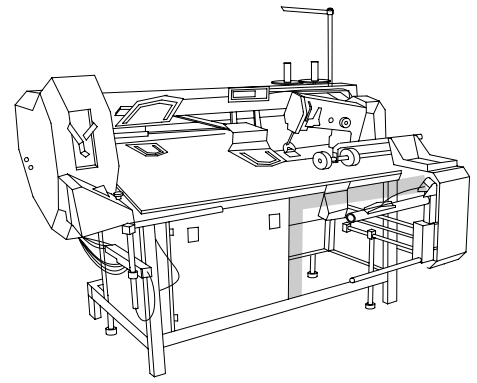

siehe Seite 7-2
see page 7-2
voir page 7-2
véase la página 7-2

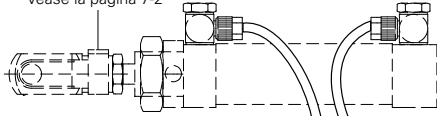

25-308 820-40 [96]

25-308 820-40 [96]

siehe Seite 7-4
see page 7-4
voir page 7-4
véase la página 7-4

99-136 072-95

25-308 820-40 [96]

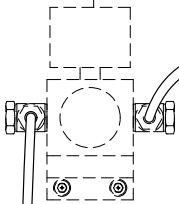

25-308 820-40 [96]

25-308 820-40 [96]

99-135 617-95

siehe Seite 7-4
see page 7-4
voir page 7-4
véase la página 7-4

99-136 072-95

25-308 820-40 [96]

25-308 820-40 [96]

25-308 820-40 [96]

siehe Seite 7-4
see page 7-4
voir page 7-4
véase la página 7-4

25-308 820-40 [96]

25-308 820-40 [96]

Anschluß siehe Seite 9-1
For connection see page 9-1
Raccord, cf. page 9-1
Para la conexión, véase la pág. 9-1

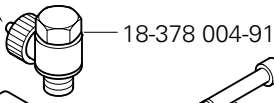

18-378 004-91

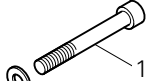

11-130 257-25 (2x)

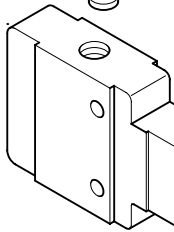

12-305 144-25 (2x)

99-135 556-91

18-372 004-91



Anschluß siehe Seite 10-13
For connection see page 10-13
Raccord, cf. page 10-13
Para la conexión, véase la pág. 10-13

25-308 820-60 [96]

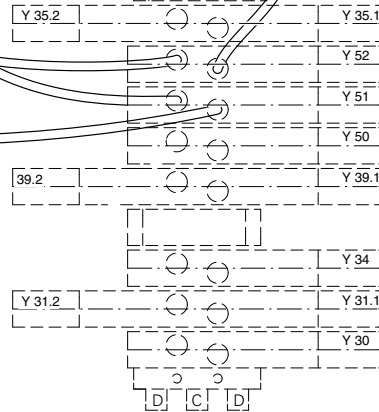

siehe Seite 9-3
see page 9-3
voir page 9-3
véase la página 9-3

Anschluß siehe Seite 9-6
For connection see page 9-6
Raccord, cf. page 9-6
Para la conexión, véase la pág. 9-6

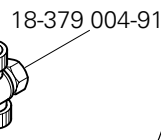

18-379 004-91

25-308 820-60 [96]

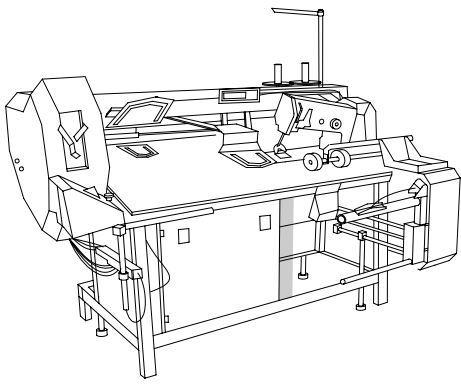

Anschluß siehe Seite 10-11
 For connection see page 10-11
 Raccord, cf. page 10-11
 Para la conexión, véase la pág. 10-11

91-291 512-91

Anschluß siehe Seite 9-5
 For connection see page 9-5
 Raccord, cf. page 9-5
 Para la conexión, véase la pág. 9-5

99-137-170-91

Anschluß siehe Seite 9-5
 For connection see page 9-5
 Raccord, cf. page 9-5
 Para la conexión, véase la pág. 9-5

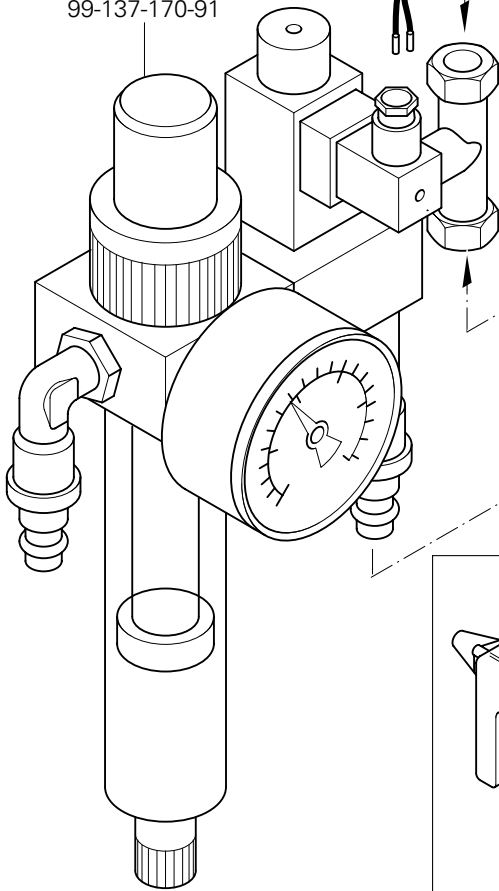

95-633 660-91

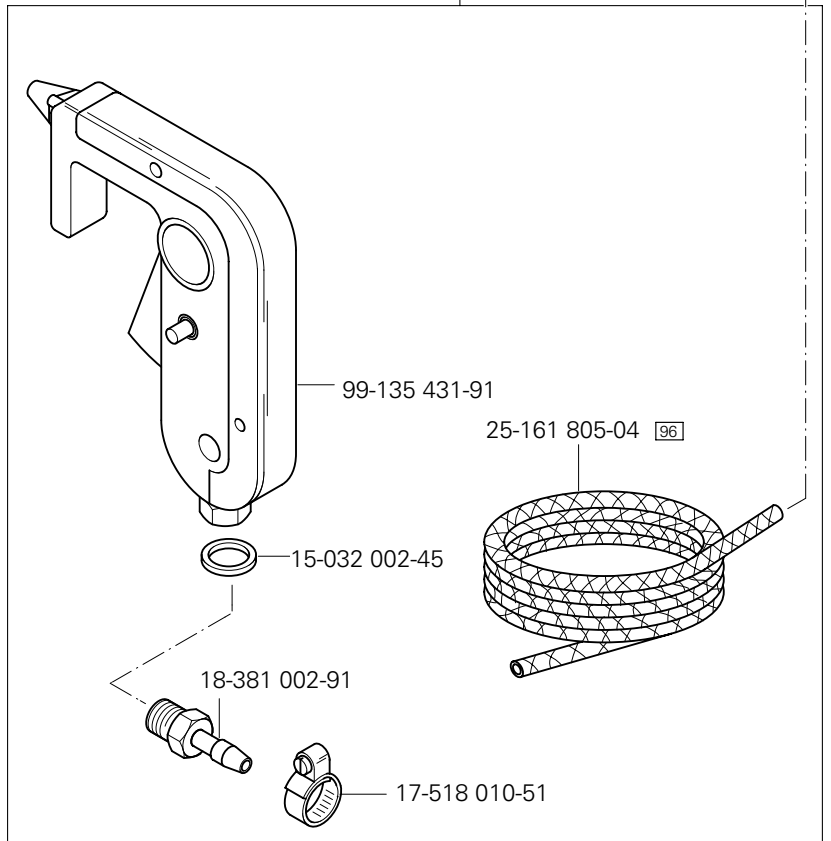

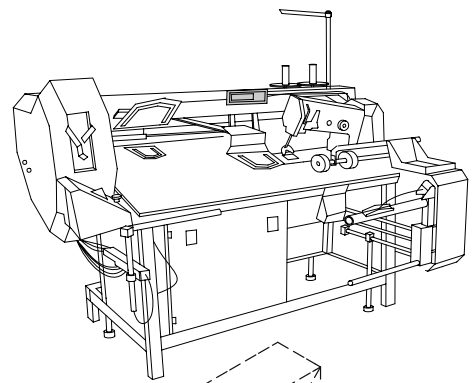

siehe Seite 5-1
see page 5-1
voir page 5-1
véase la página 5-1

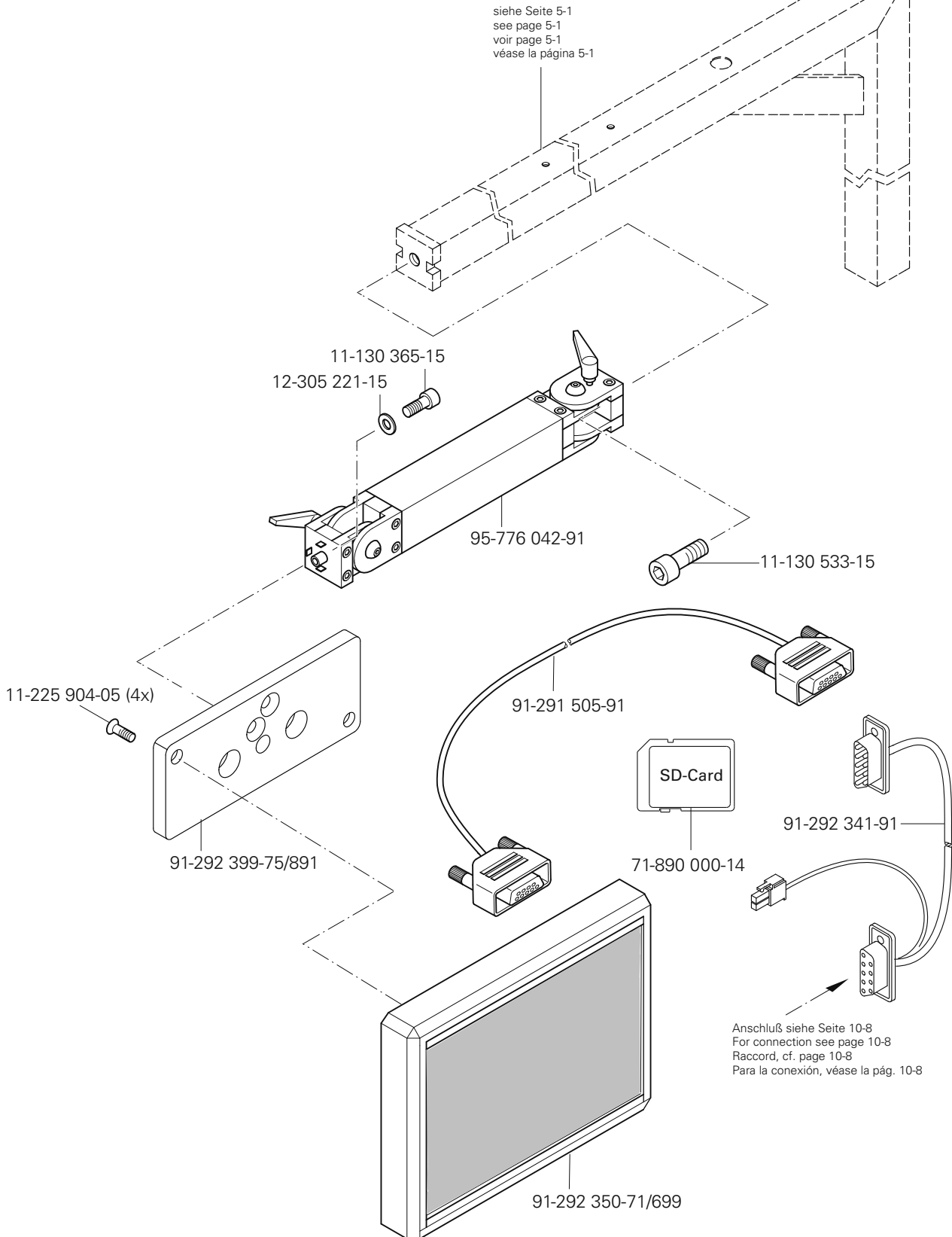

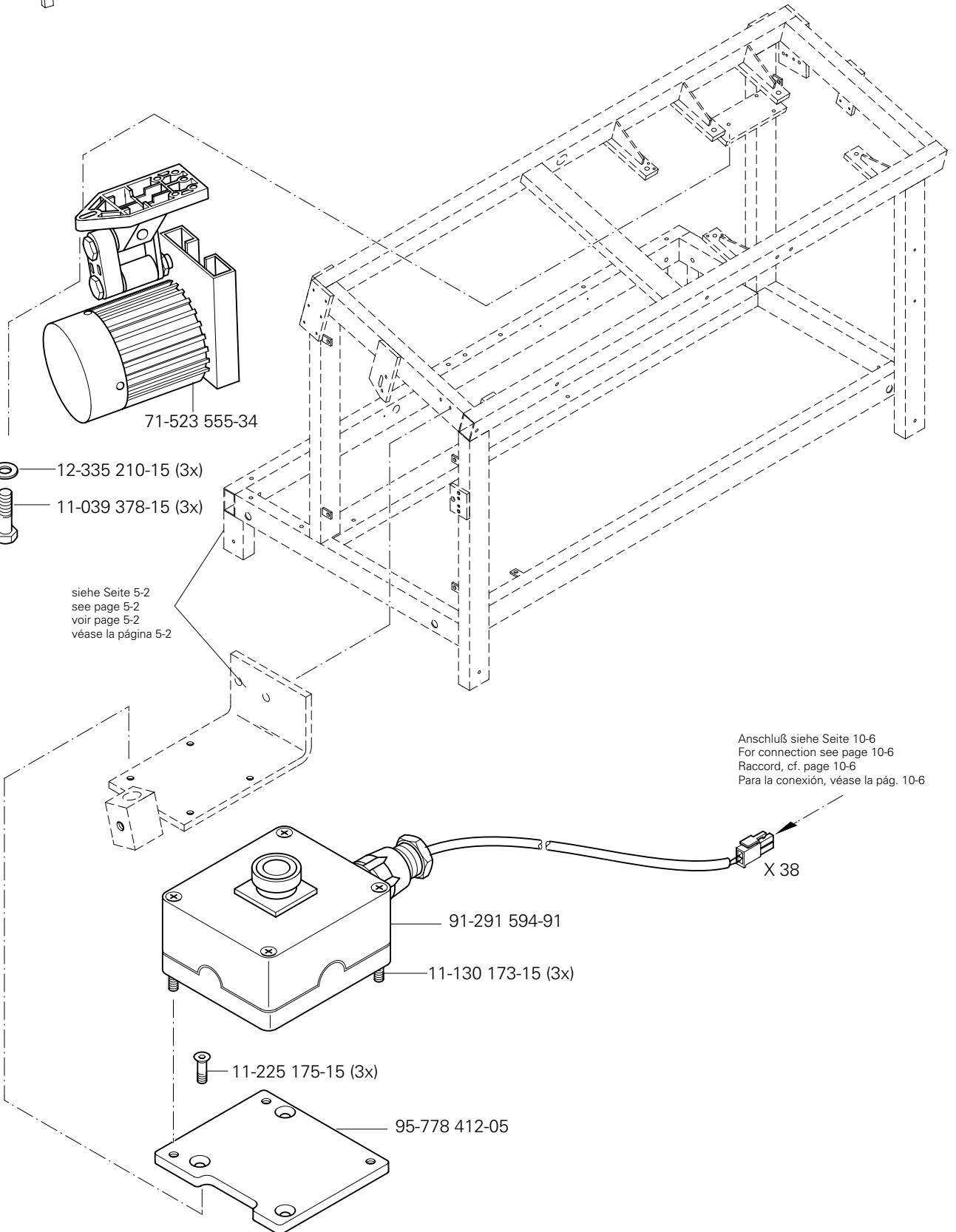
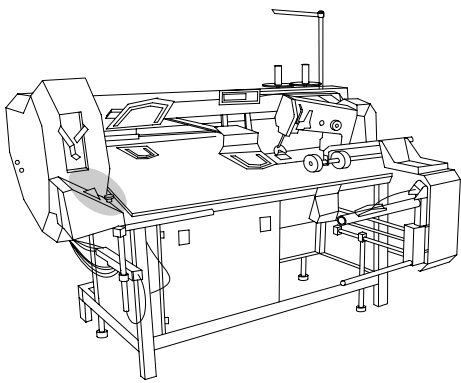

siehe Seite 5-2
 see page 5-2
 voir page 5-2
 véase la página 5-2

Anschluß siehe Seite 10-6
 For connection see page 10-6
 Raccord, cf. page 10-6
 Para la conexión, véase la pág. 10-6

10.03

Zweihandbedienung
 Operation with both hands
 Commande à deux mains
 Manejo a dos manos

PFAFF 3588-12/021

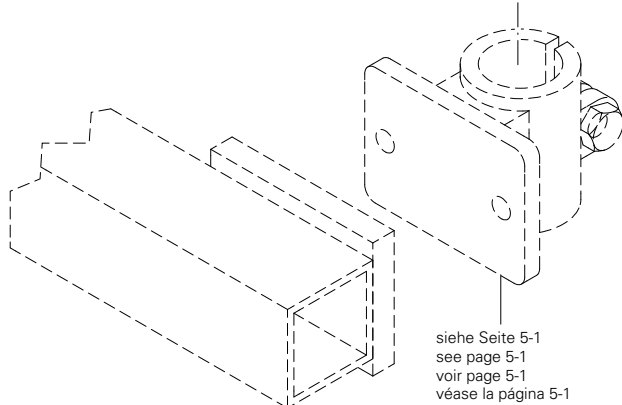
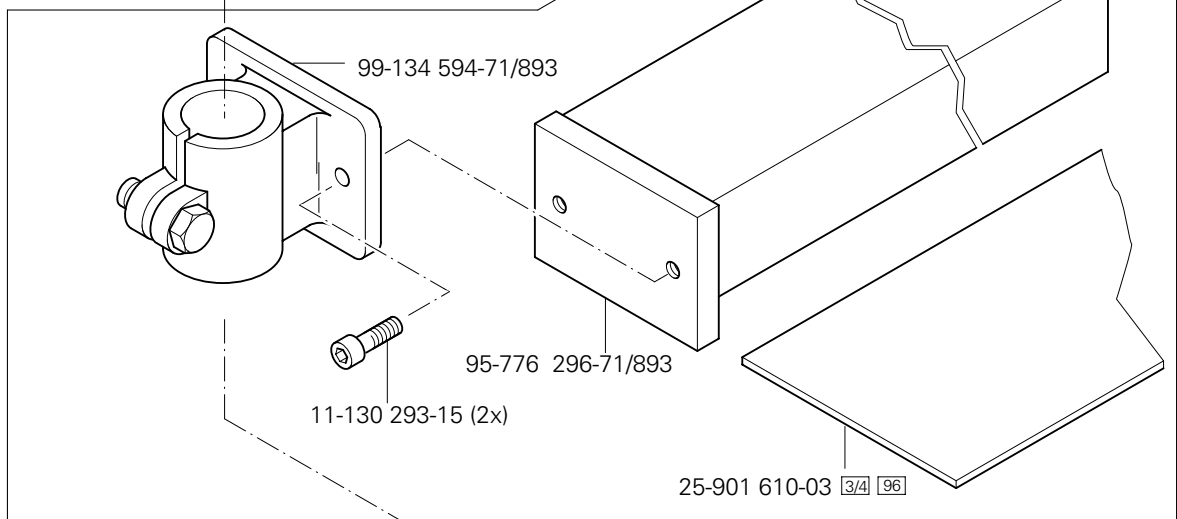
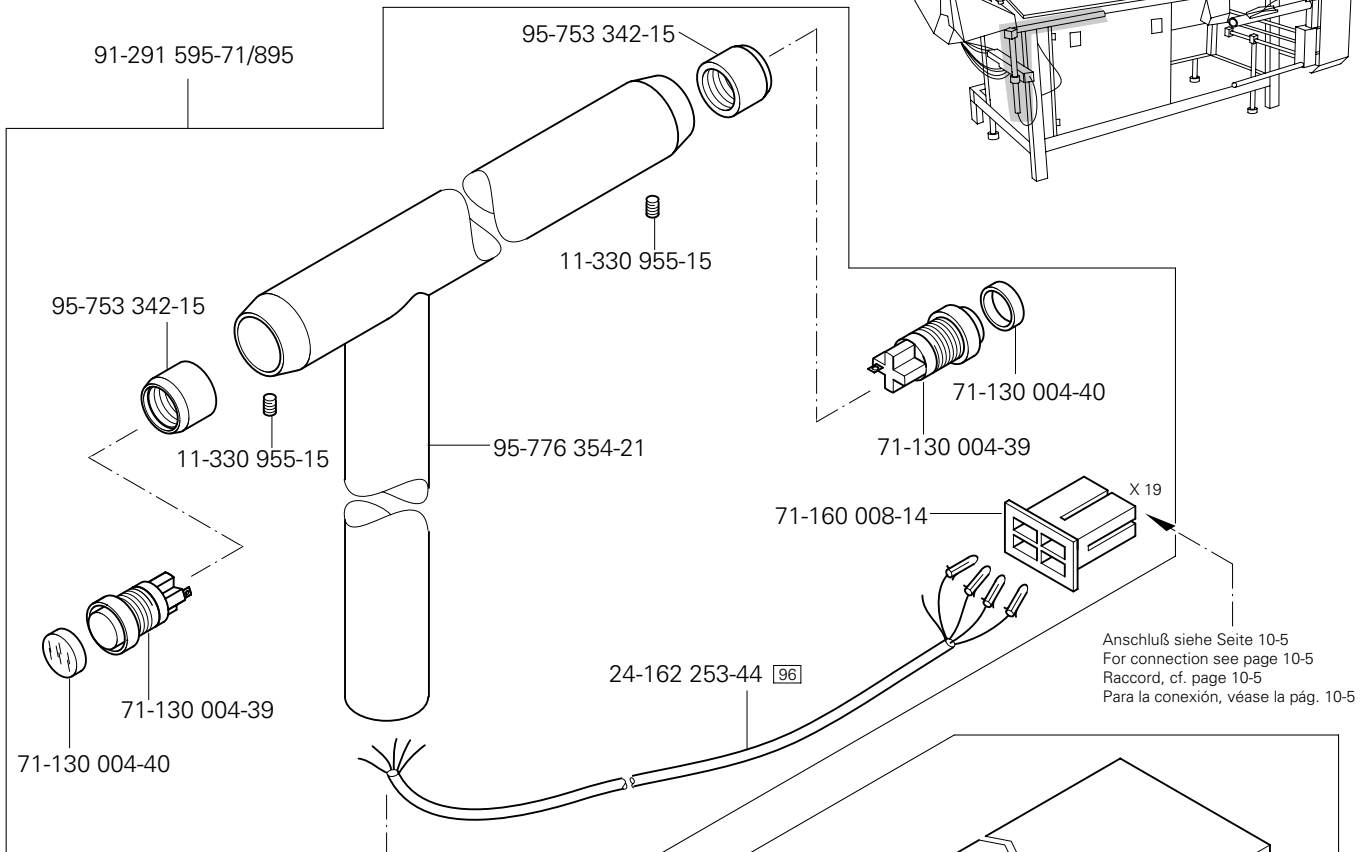
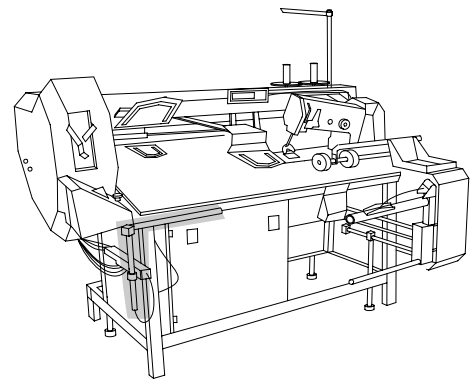

95-776 298-71/893

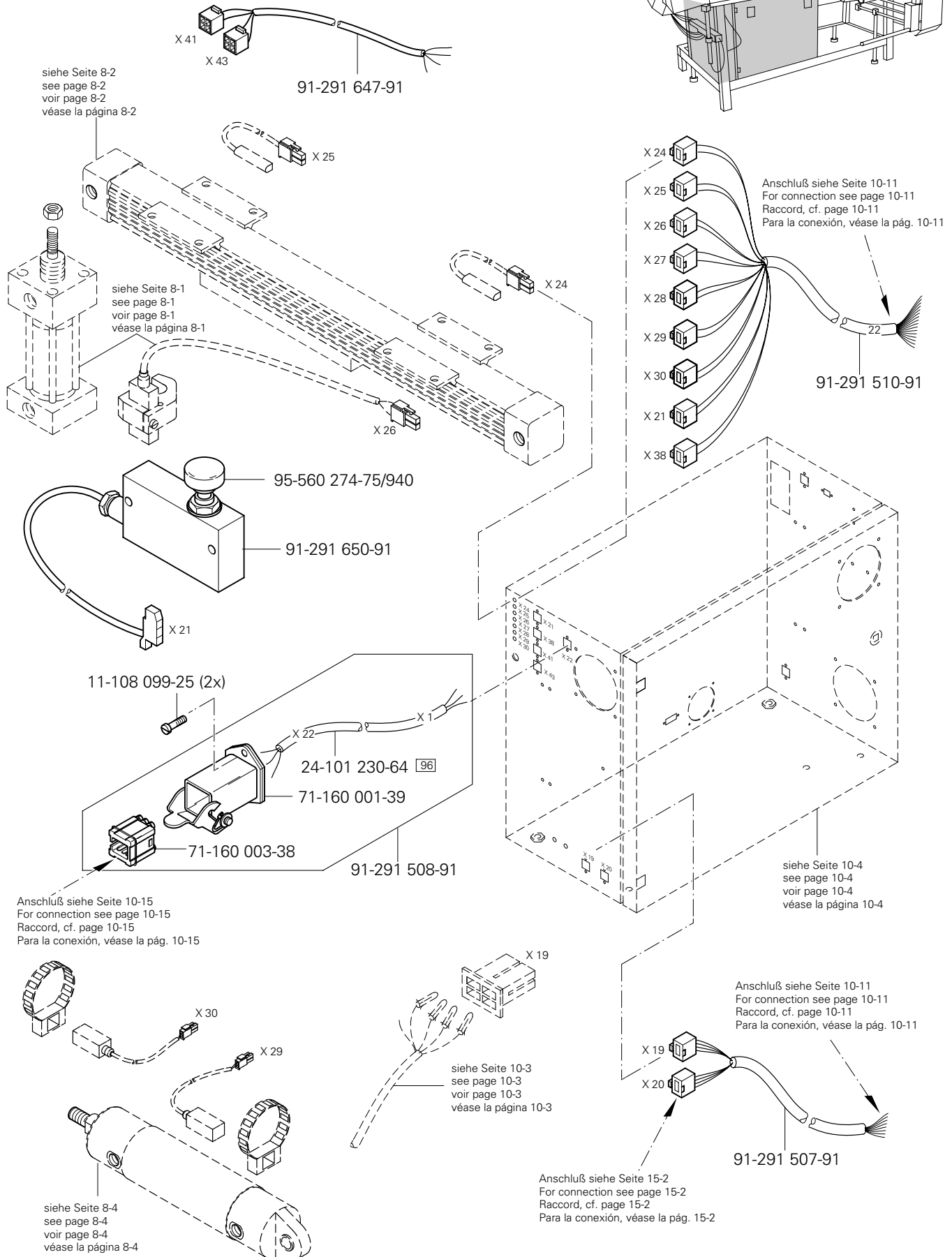
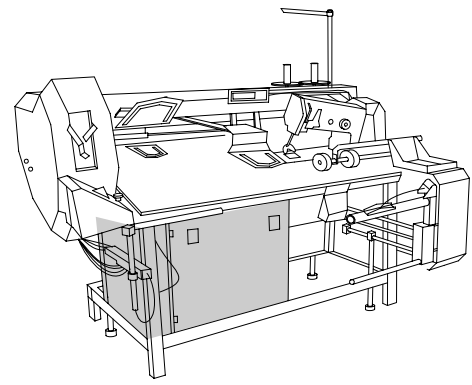

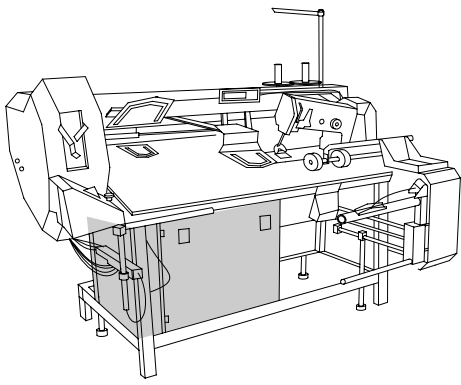

Steuergerät
Control device
Boîte de commande
Caja de mandos

PFAFF 3588-12/021

10.04

Anschluß siehe Seite 10-11
For connection see page 10-11
Raccord, cf. page 10-11
Para la conexión, véase la pág. 10-11

siehe Seite 10-2
see page 10-2
voir page 10-2
véase la página 10-2

Anschluß siehe Seite 10-11
For connection see page 10-11
Raccord, cf. page 10-11
Para la conexión, véase la pág. 10-11

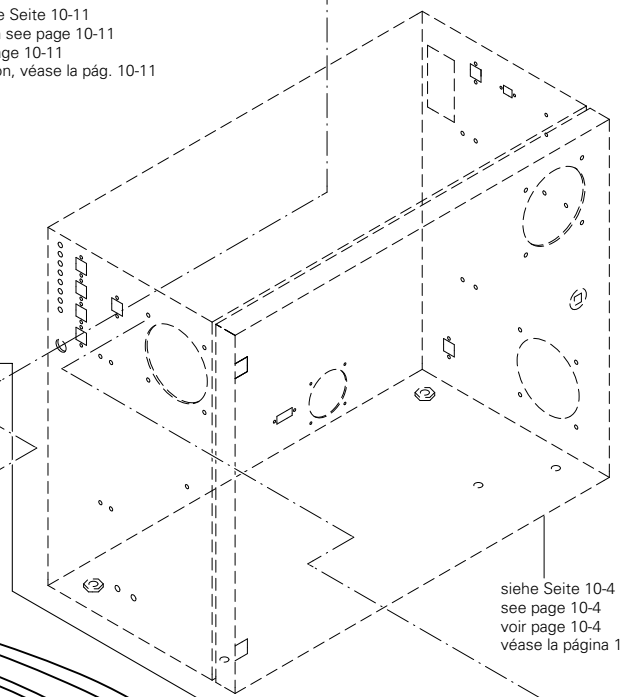
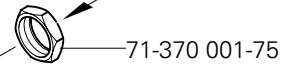
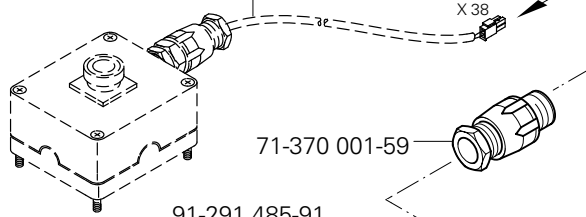

siehe Seite 10-4
see page 10-4
voir page 10-4
véase la página 10-4

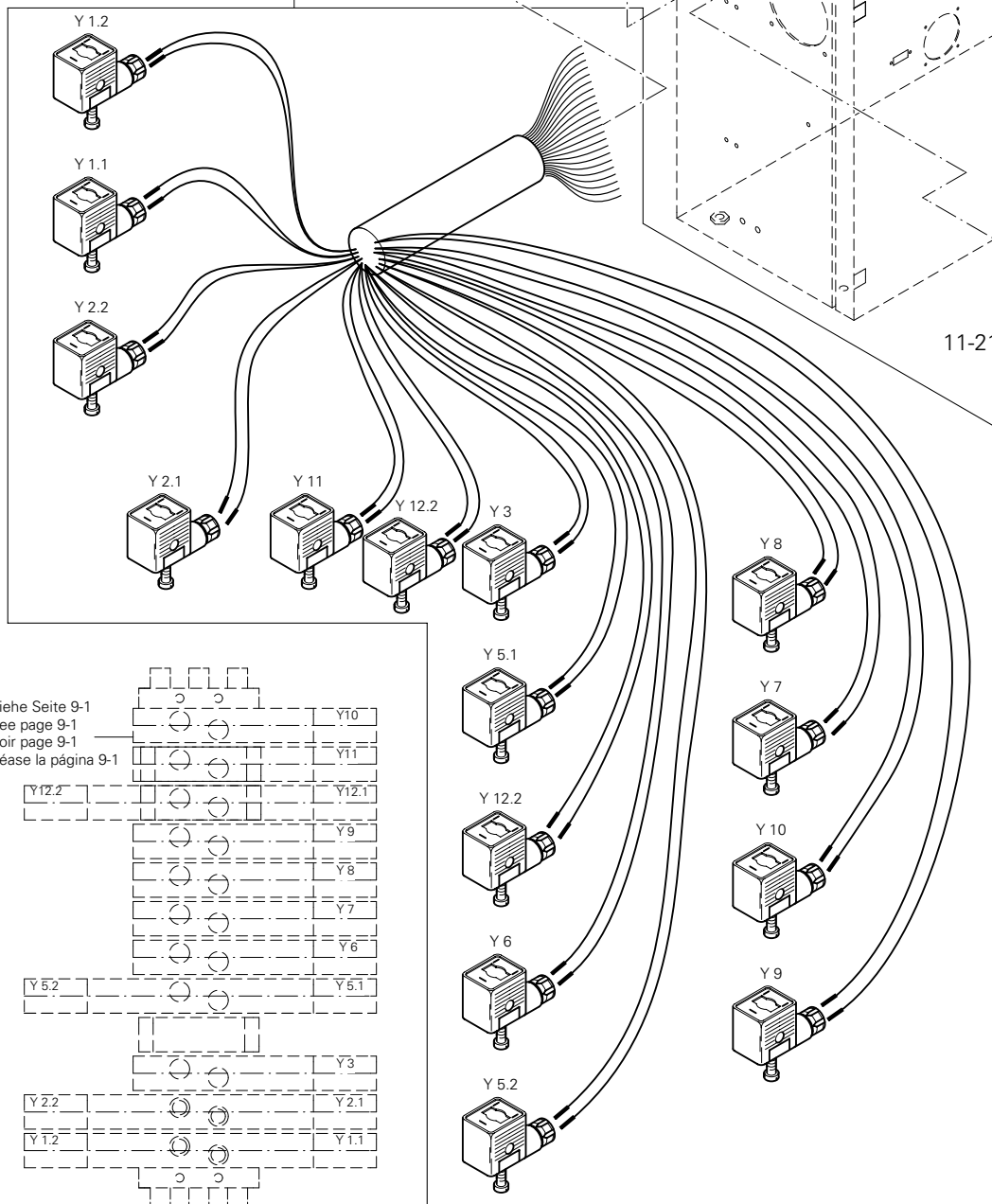

11-210 169-25 (4x)

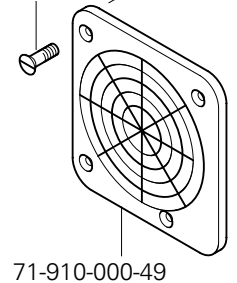

siehe Seite 9-1
see page 9-1
voir page 9-1
véase la página 9-1

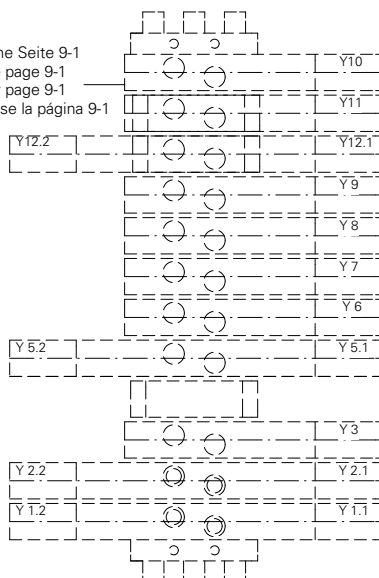

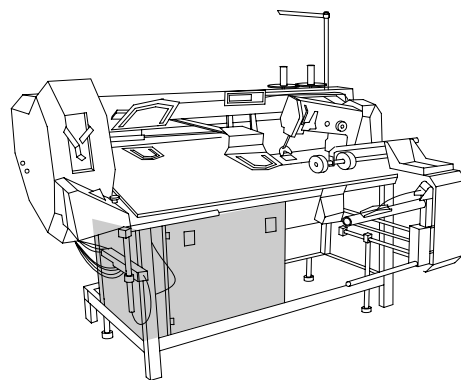

siehe Seite 10-4
see page 10-4
voir page 10-4
véase la página 10-4

Anschluß siehe Seite 10-8
For connection see page 10-8
Raccord, cf. page 10-8
Para la conexión, véase la pág. 10-8

Anschluß siehe Seite 10-9
For connection see page 10-9
Raccord, cf. page 10-9
Para la conexión, véase la pág. 10-9

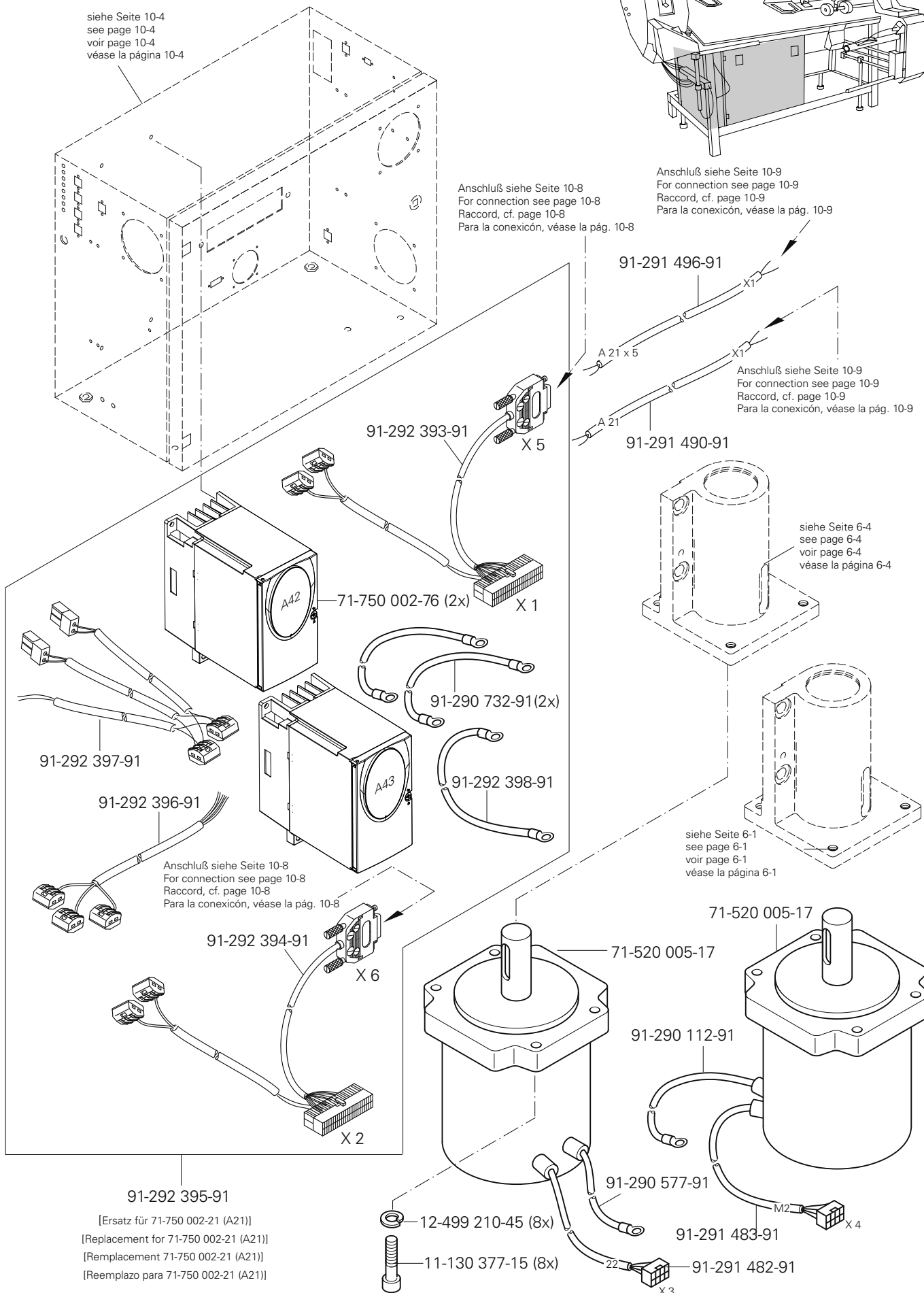

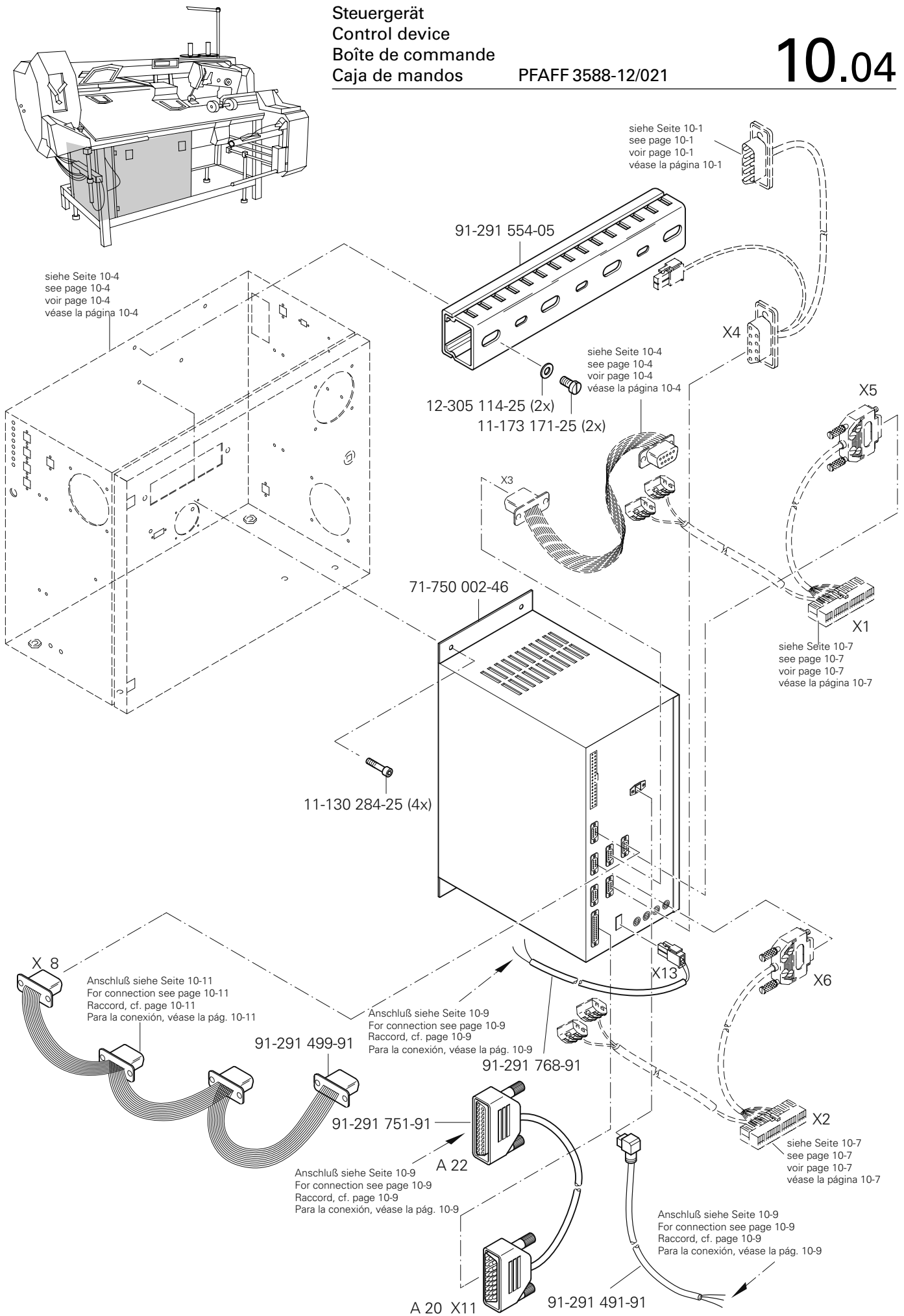

10.04

Steuergerät Control device Boîte de commande Caja de mandos

PFAFF 3588-12/021

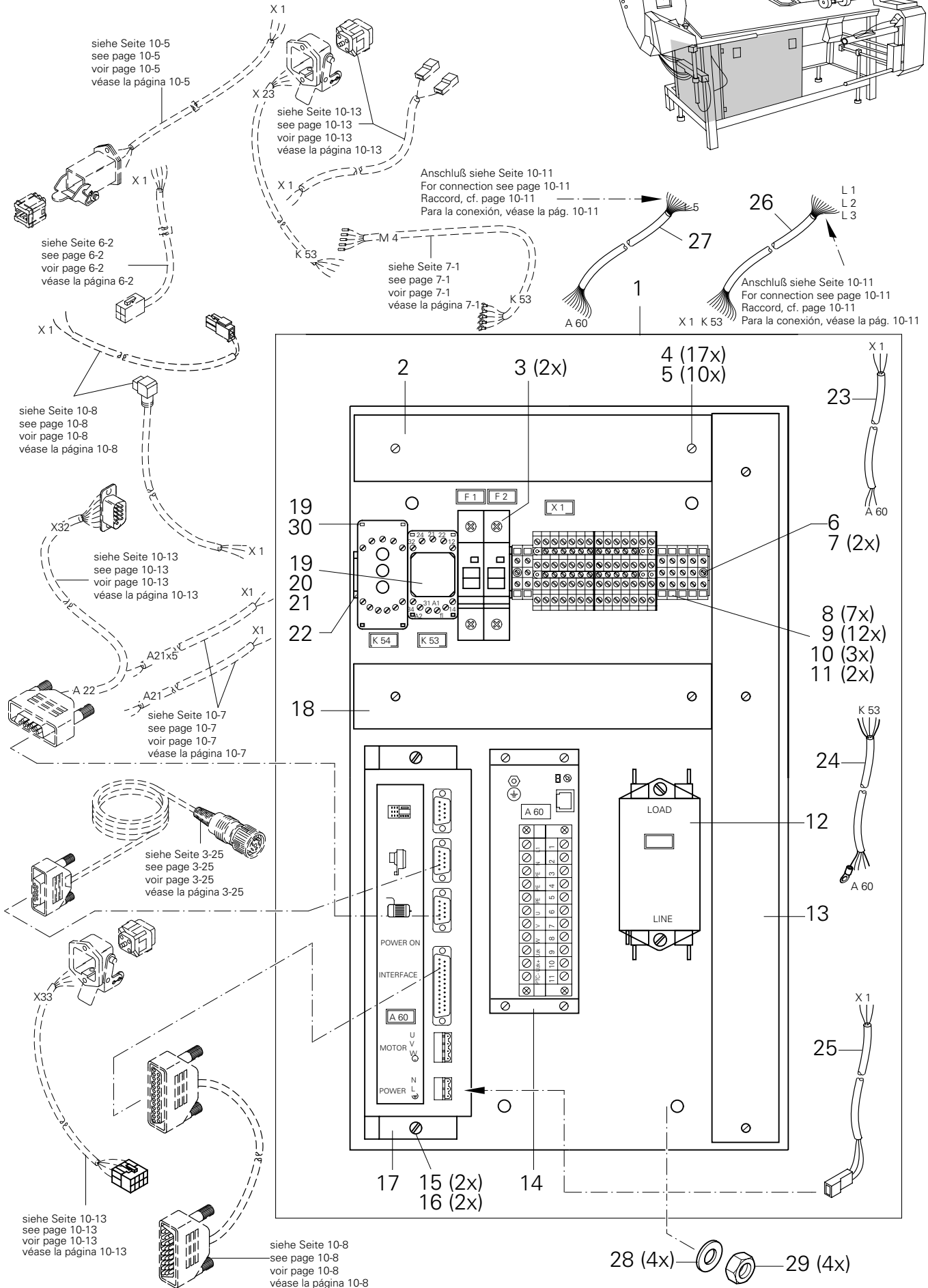
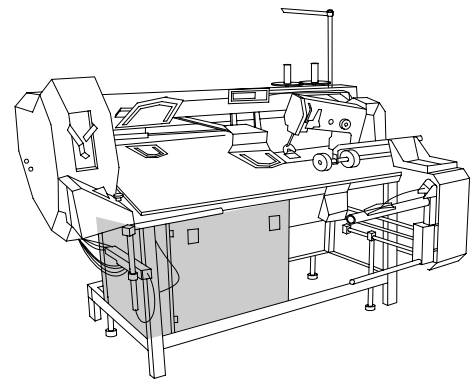

Pos.-Nr. Item No. N° pos. N° de pos.	Bestellnummer Part number N° de commande N° de pedido	Teile-Benennung Description Désignation Denominación	Pos.-Nr. Item No. N° pos. N° de pos.	Bestellnummer Part number N° de commande N° de pedido	Teile-Benennung Description Désignation Denominación
1	91-291 515-91	Montageplatte Mounting plate Plaque de montage Placa de montaje	17	71-590 007-11	Steuergerät P 200 Control unit Appareil de commande Aparato de mando
2	91-291 517-05	Kabelkanal Cable channel Canal de câbles Canal para cables	18	91-291 550-05	Kabelkanal Cable channel Canal de câbles Canal para cables
3	71-150 000-69	Sicherungsautomat 1 pol. 16 A Overload cutout, 1 -pole Couple-circuit 1 pôle Fusible automático 1 polo	19	71-190 001-18	Relaisfassung Relay holder Douille du relais Portarelés
4	11-173 171-25	Flachkopfschraube M4 x 6 Countersunk head screw Vis à tête plate Tornillo de cabeza plana	20	71-190 002-13	Haltebügel Retainer Etrier de maintien Estribo de sujecion
5	12-510 111-25	Scheibe A4,3 Washer Rondelle Arandela	21	71-190 000-60	Relais 24V Relay Relais Relé
6	91-291 674-45	Tragschiene Support rail Réglette de bornes Regleta portabornes	22	91-291 516-05	Trageschiene Support rail Réglette de bornes Regleta portabornes
7	11-210 165-15	Senkschraube M4 x 6 Countersunk screw Vis à tête noyée Tornillo avellanado	23	91-291 511-91	Leitung Tube Tuyau Tubo
8	71-210 002-21	Schutzleiterklemme Ground wire terminal Borne de terre Borne de puesta a tierra	24	91-291 489-91	Leitung Tube Tuyau Tubo
9	71-210 002-52	Anreihklemme Terminal strip Borne enfilable Borne	25	91-291 492-91	Leitung Tube Tuyau Tubo
10	71-210 002-50	Abschlußplatte Cover Plaque de fermeture Tapa	26	91-291 498-91	Leitung Tube Tuyau Tubo
11	71-210 002-40	Verbindungssteg Connector Barrette de jonction Clavija de unión	27	91-291 487-91	Leitung Tube Tuyau Tubo
12	71-480 000-12	Entstörfilter Suppressor Filtre antiparasites Filtro antiparásito	28	12-512 220-05	Scheibe A8,4 Washer Rondelle Arandela
13	91-291 549-05	Kabelkanal Cable channel Canal de câbles Canal para cables	29	12-005 215-15	Sechskantmutter M8 Hexagon nut Ecrou à six pans Tuerca hexagonal
14	91-291 586-93/0 01	Frequenzumrichter Frequency converter Changeur de fréquence Convertidor de frecuencias	30	71-710 000-82	Grenzwertmelder Limit indicator Indicateur de valeur Indicador valor lim.
15	11-130 299-25	Zylinderschraube M6 x 20 Pan-head screw Vis à tête cylindrique Tornillo cilíndrico			
16	12-512 170-25	Scheibe A6,4 Washer Rondelle Arandela			

10.04

Steuergerät Control device Boîte de commande Caja de mandos

PFAFF 3588-12/021

siehe Seite 3-20
see page 3-20
voir page 3-20
véase la página 3-20

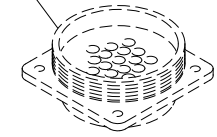

siehe Seite 6-6
see page 6-6
voir page 6-6
véase la página 6-6

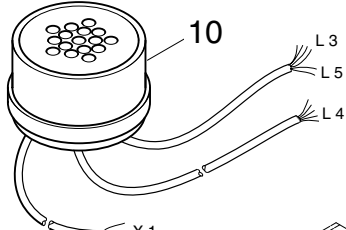
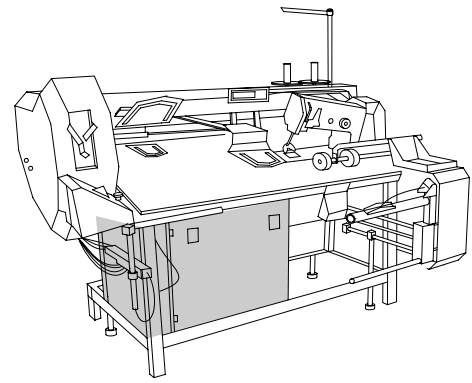
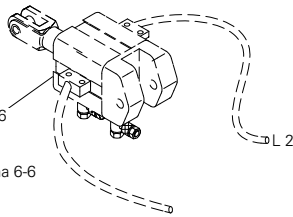

siehe Seite 9-6
see page 9-6
voir page 9-6
véase la página 9-6

siehe Seite 10-5
see page 10-5
voir page 10-5
véase la página 10-5

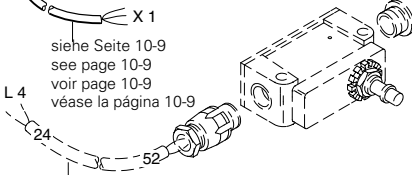

siehe Seite 10-9
see page 10-9
voir page 10-9
véase la página 10-9

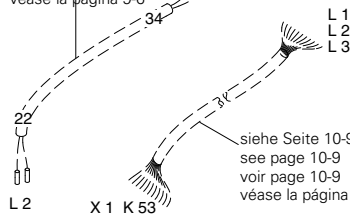

siehe Seite 10-9
see page 10-9
voir page 10-9
véase la página 10-9

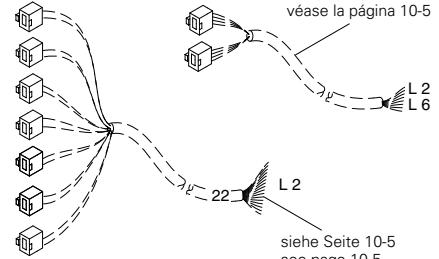

siehe Seite 10-5
see page 10-5
voir page 10-5
véase la página 10-5

siehe Seite 7-6
see page 7-6
voir page 7-6
véase la página 7-6

siehe Seite 10-9
see page 10-9
voir page 10-9
véase la página 10-9

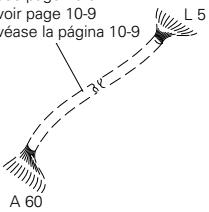

siehe Seite 10-8
see page 10-8
voir page 10-8
véase la página 10-8

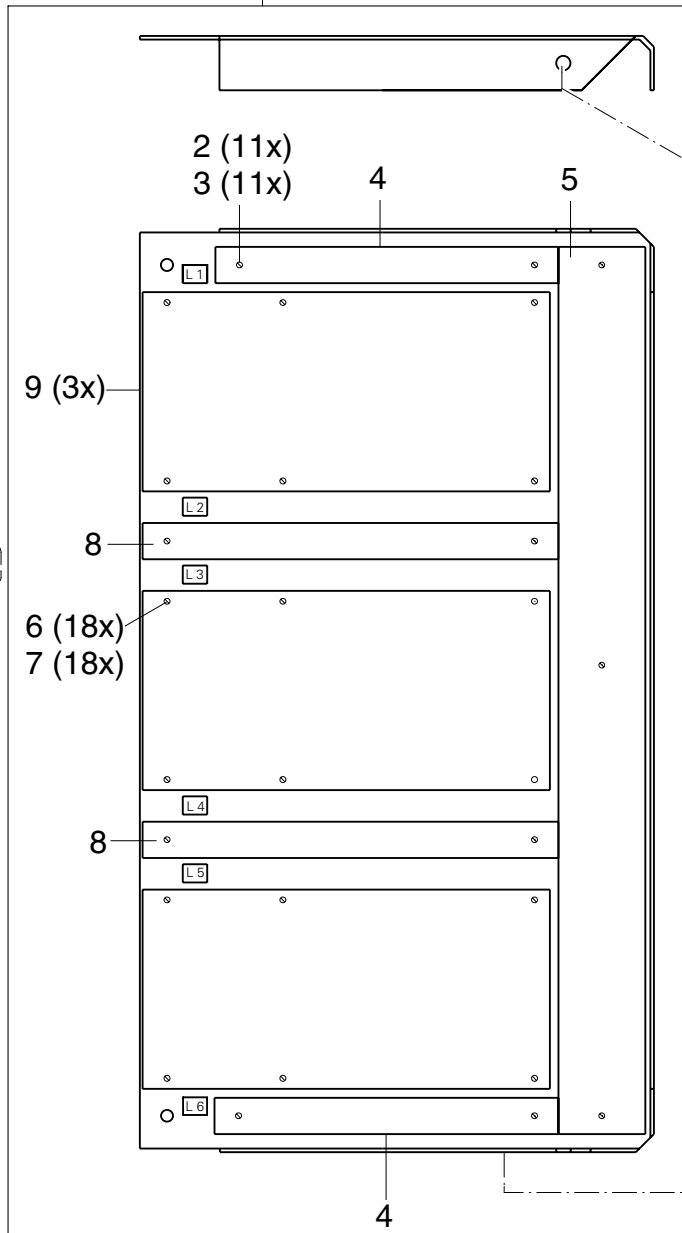
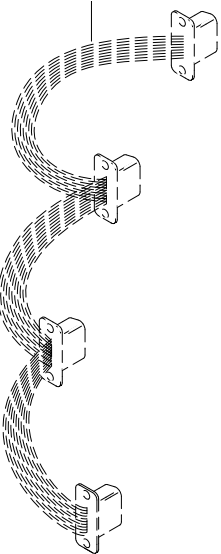

siehe Seite 10-6
see page 10-6
voir page 10-6
véase la página 10-6

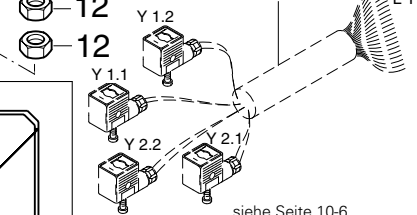

siehe Seite 10-6
see page 10-6
voir page 10-6
véase la página 10-6

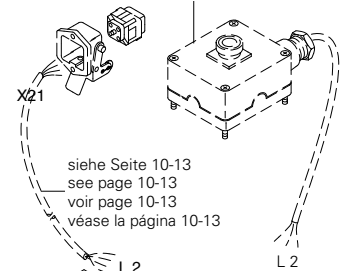

siehe Seite 10-13
see page 10-13
voir page 10-13
véase la página 10-13

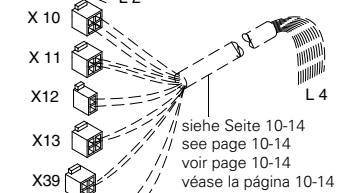

siehe Seite 10-14
see page 10-14
voir page 10-14
véase la página 10-14

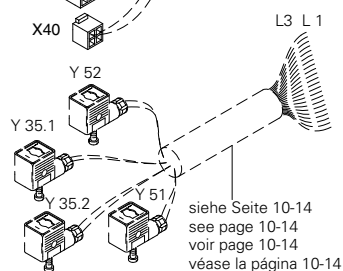

siehe Seite 10-14
see page 10-14
voir page 10-14
véase la página 10-14

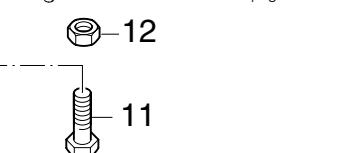

Pos.-Nr. Item No. N° pos. N° de pos.	Bestellnummer Part number N° de commande N° de pedido	Teile-Benennung Description Désignation Denominación	Pos.-Nr. Item No. N° pos. N° de pos.	Bestellnummer Part number N° de commande N° de pedido	Teile-Benennung Description Désignation Denominación
1	91-291 514-91	Montageplatte Mounting plate Plaque de montage Placa de montaje			
2	11-173 171-25	Flachkopfschraube M4 x 6 Countersunk head screw Vis à tête plate Tornillo de cabeza plana			
3	12-305 114-15	Scheibe A4,3 Washer Rondelle Arandela			
4	91-291 552-05	Kabelkanal Cable channel Canal de câbles Canal para cables			
5	91-291 551-05	Kabelkanal Cable channel Canal de câbles Canal para cables			
6	11-108 093-25	Zylinderschraube M3 x 6 Pan-head screw Vis à tête cylindrique Tornillo cilíndrico			
7	11-724 190-55	Abstandsbolzen M3 x 25 Spacing stud Boulon d'écartement Perno distanciador			
8	91-291 553-05	Kabelkanal Cable channel Canal de câbles Canal para cables			
9	91-291 362-93/0 01	Bestückte Leiterplatte DX 353 Solid state circuit board Carte imprimée équipée Placa de circuito impreso			
10	91-291 503-91	Leitung Tube Tuyau Tubo			
11	11-039 354-15	Sechskantschraube M8 x 12 Hexagon screw Vis à six pans Tornillo hexagonal			
12	12-005 215-15	Sechskantmutter M8 Hexagon nut Ecrou à six pans Tuerca hexagonal			

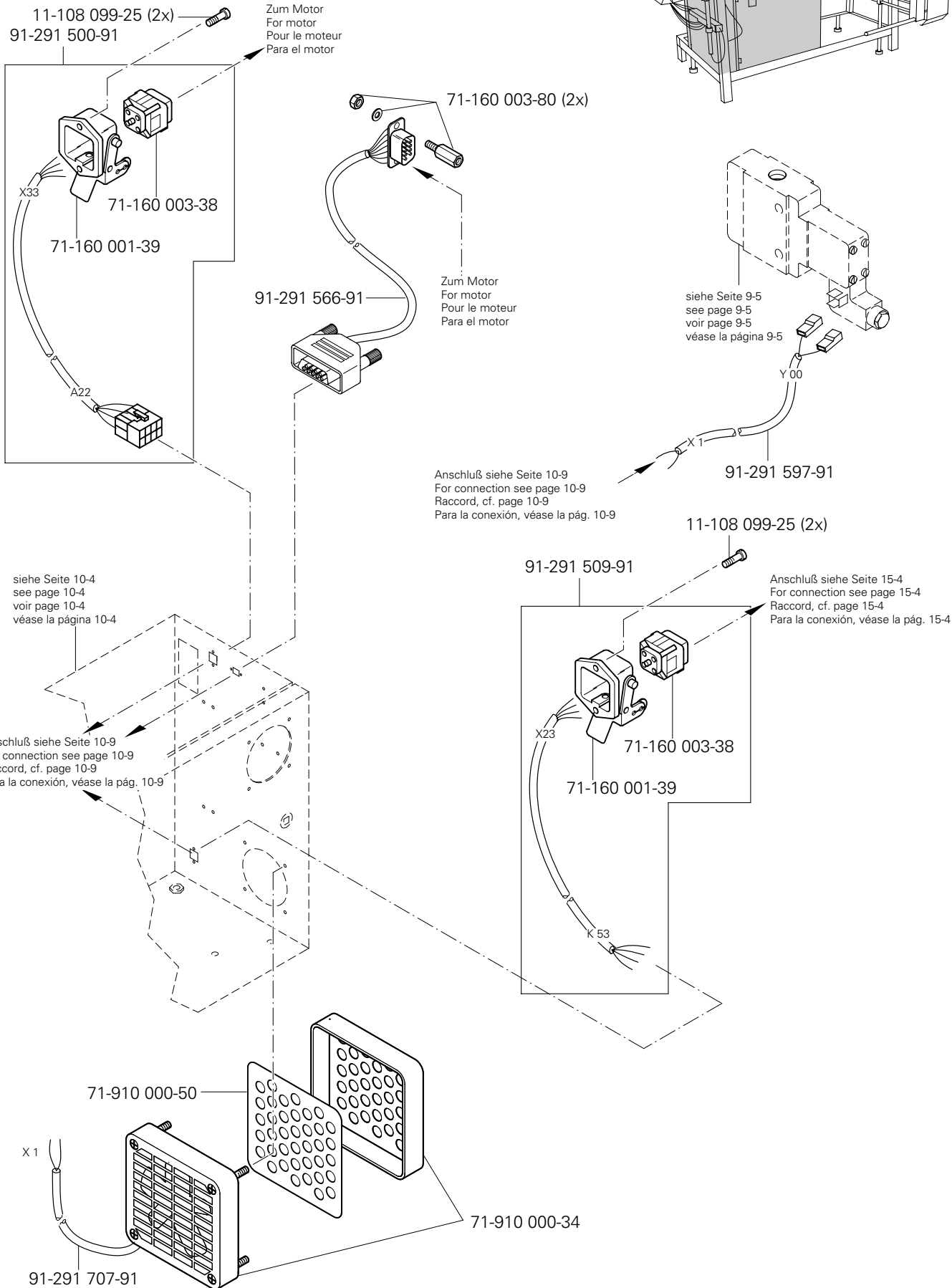
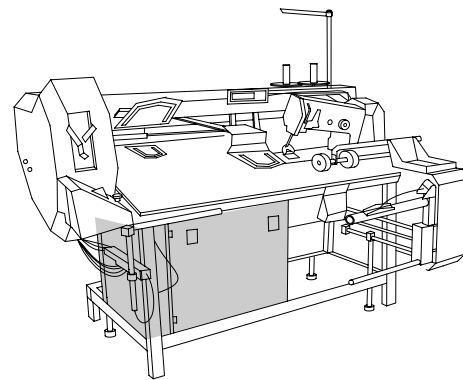

Steuergerät
Control device
Boîte de commande
Caja de mandos

PFAFF 3588-12/021

10.04

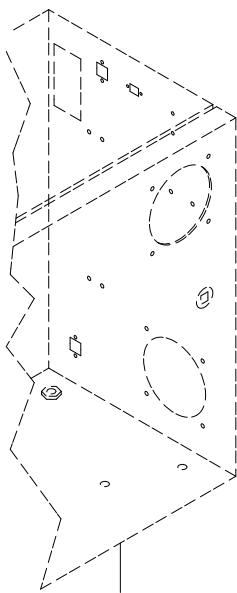
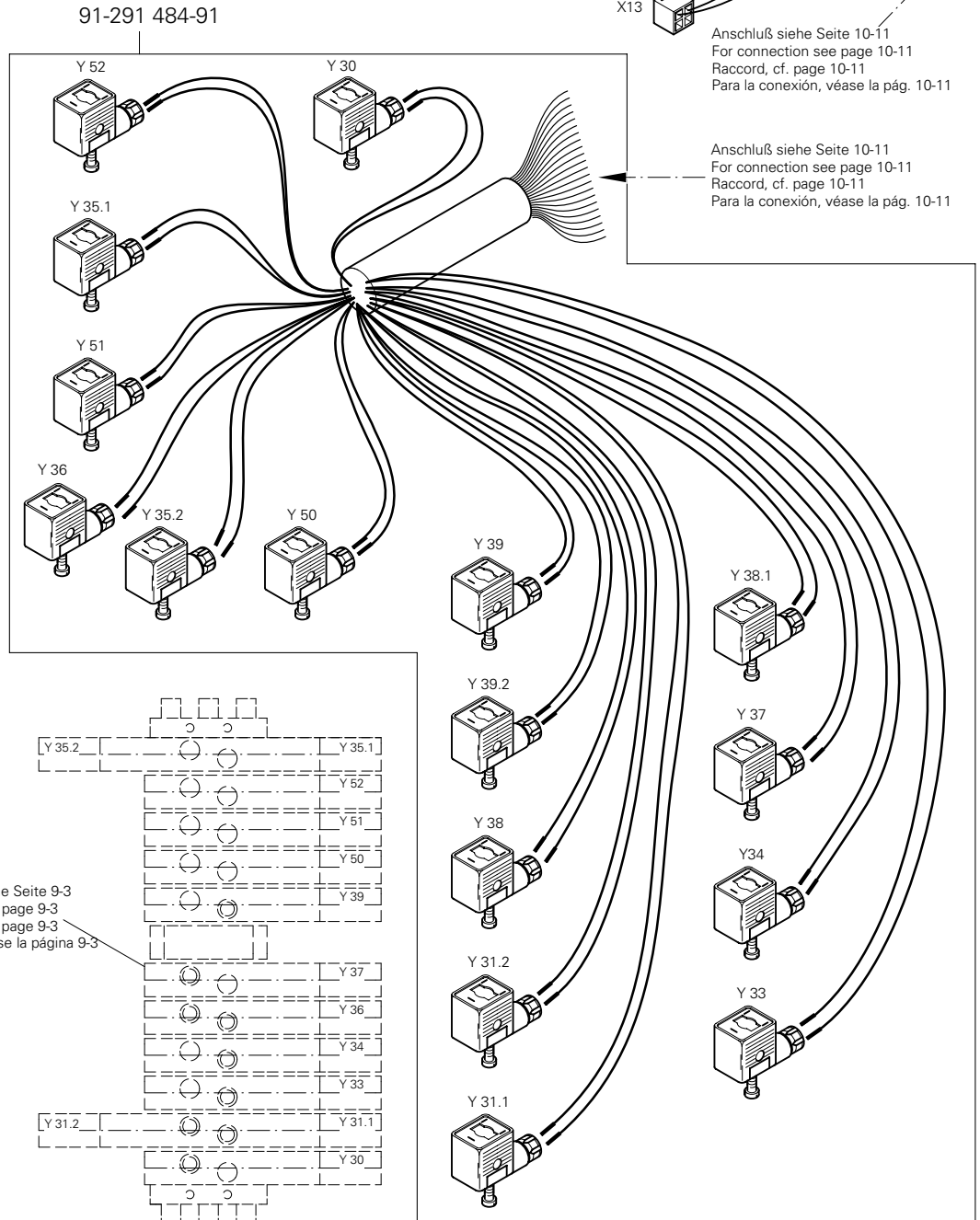
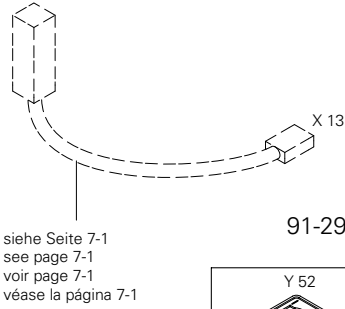
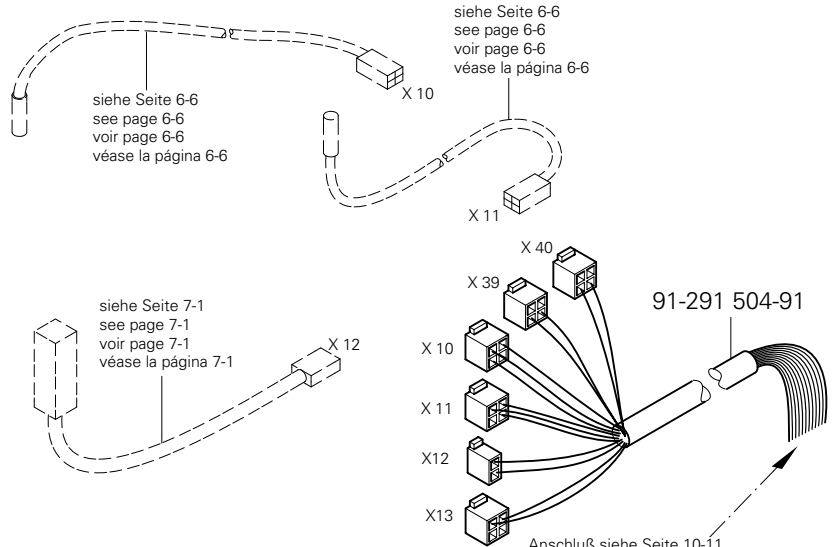
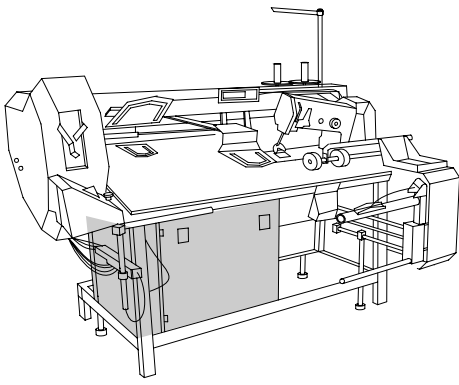

siehe Seite 9-3
see page 9-3
voir page 9-3
véase la página 9-3

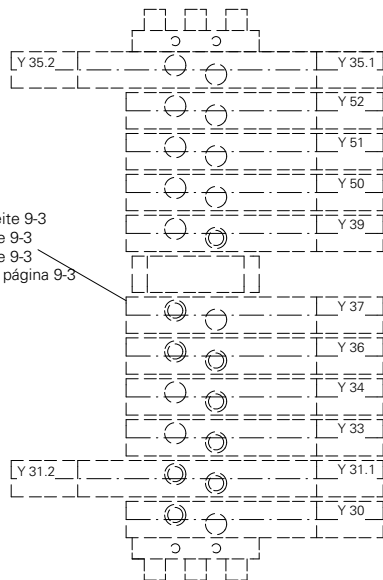

siehe Seite 10-4
see page 10-4
voir page 10-4
véase la página 10-4

10.05

Saugereinrichtung
 Vacuum system
 Dispositif d'aspiration
 Dispositivo de aspiración PFAFF 3588-12/021

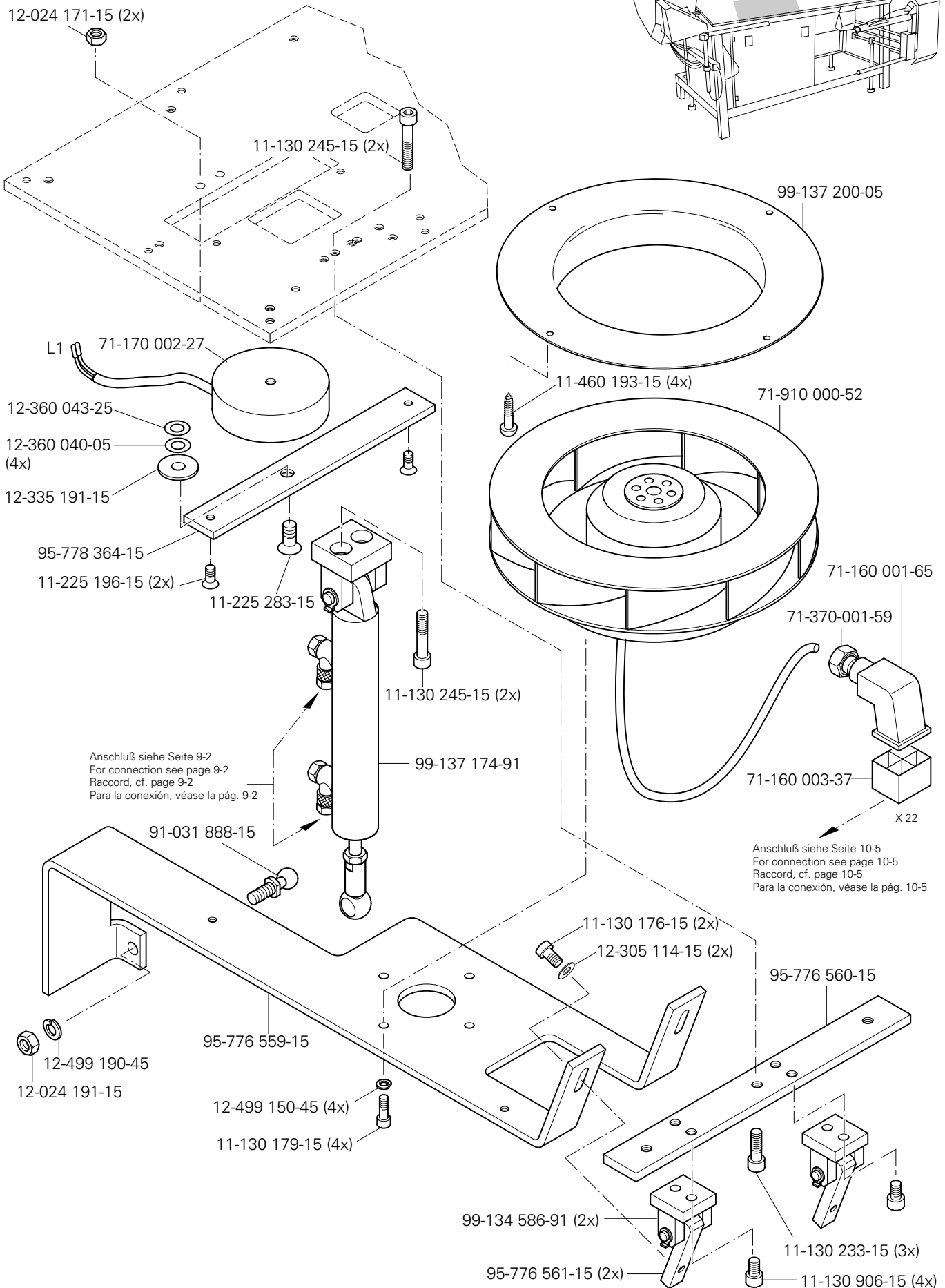
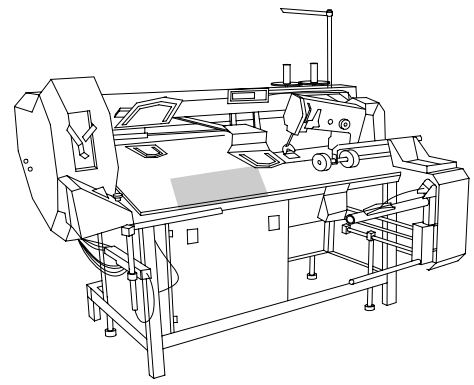

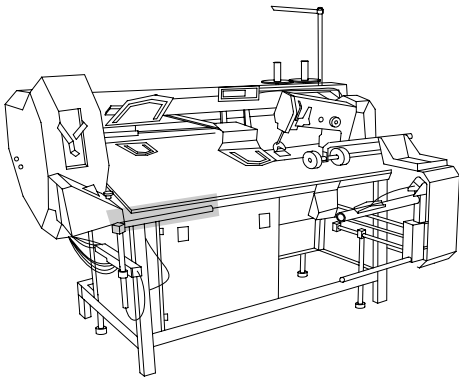

Stoffrückhaltevorrichtung

Workpiece retainer

Dispositif de rétention du tissu

Dispositivo de retención del material PFAFF 3588-12/021

10.06

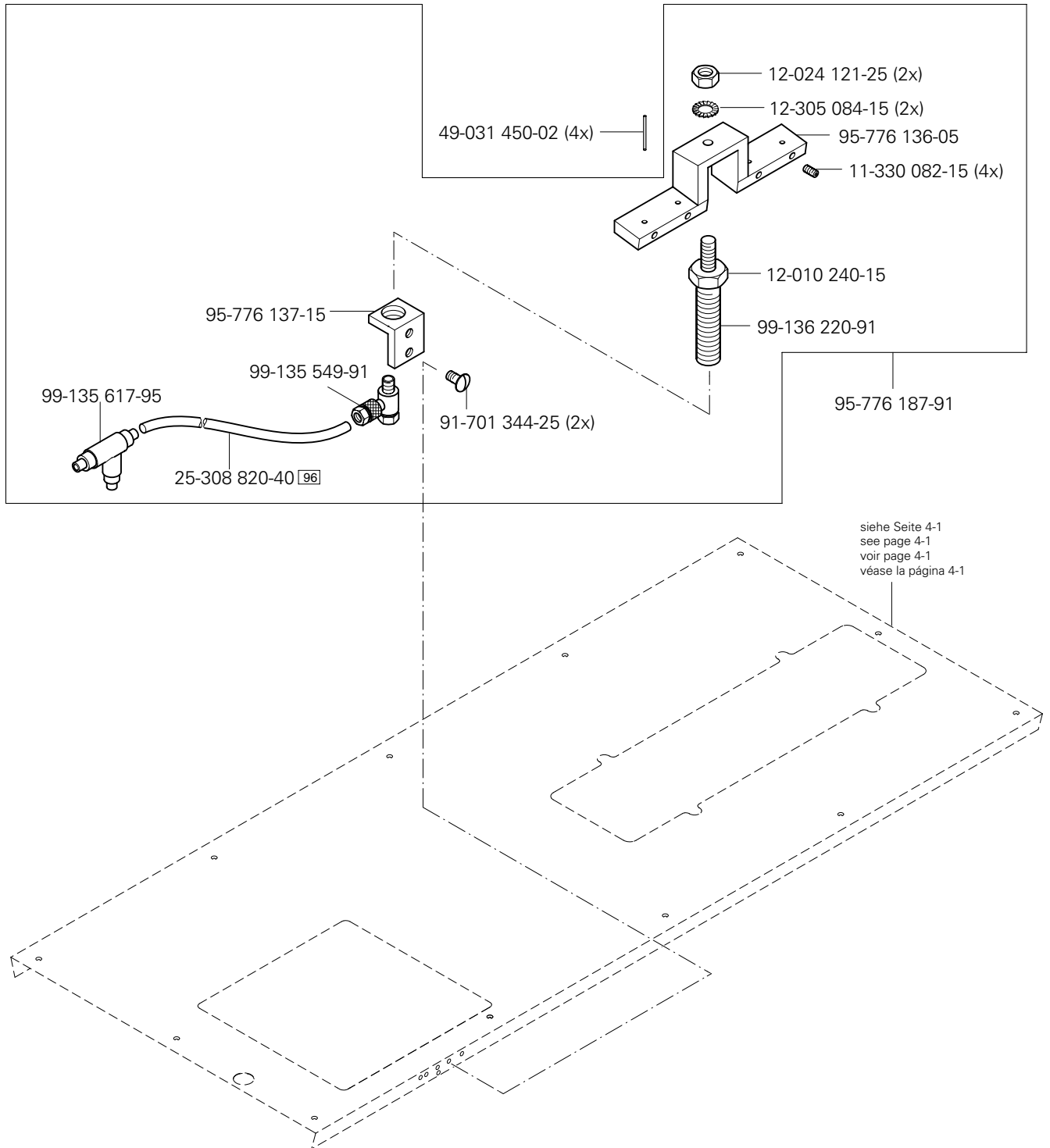

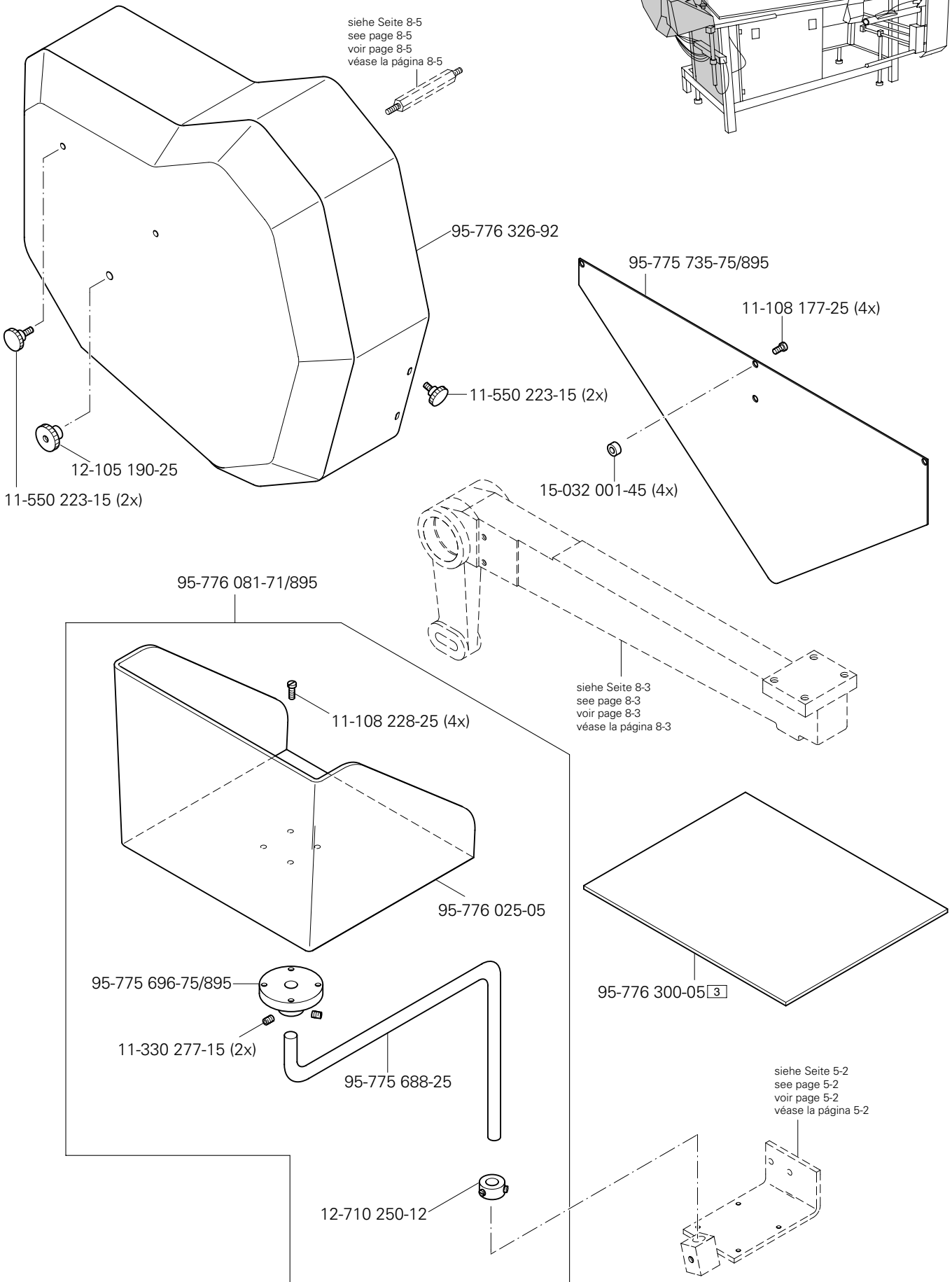
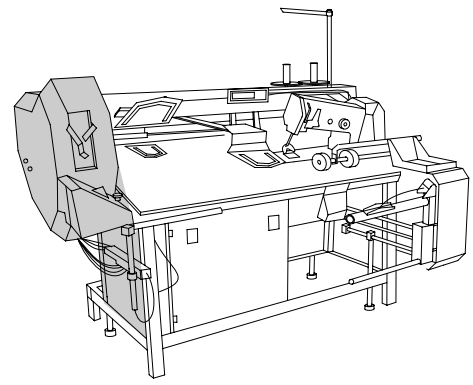

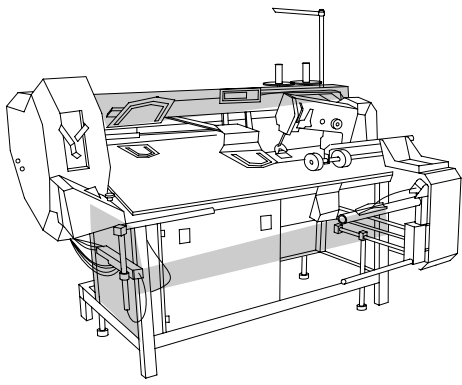

Verkleidung
 Cover panel
 Carters
 Revestimiento PFAFF 3588-12/021

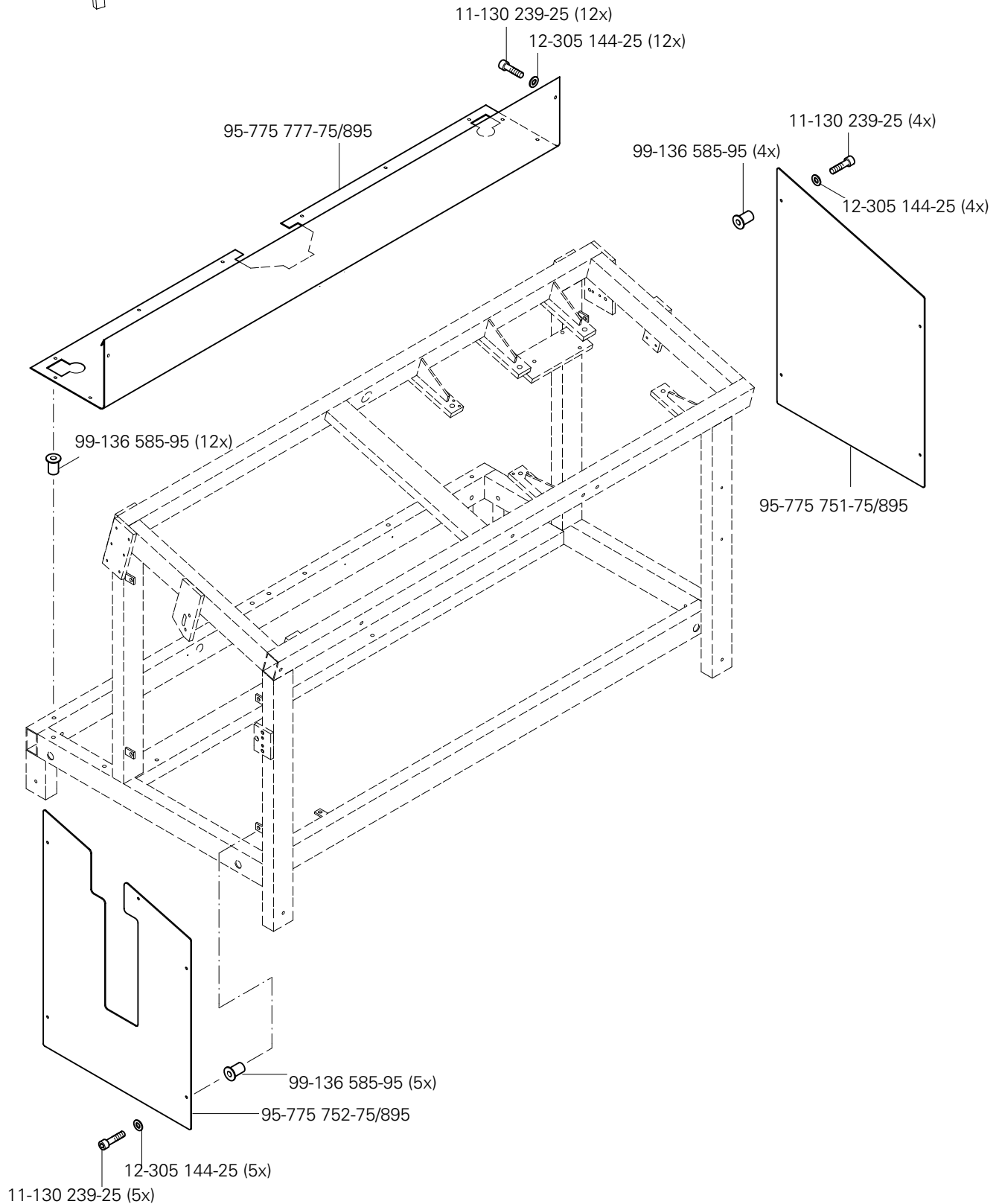

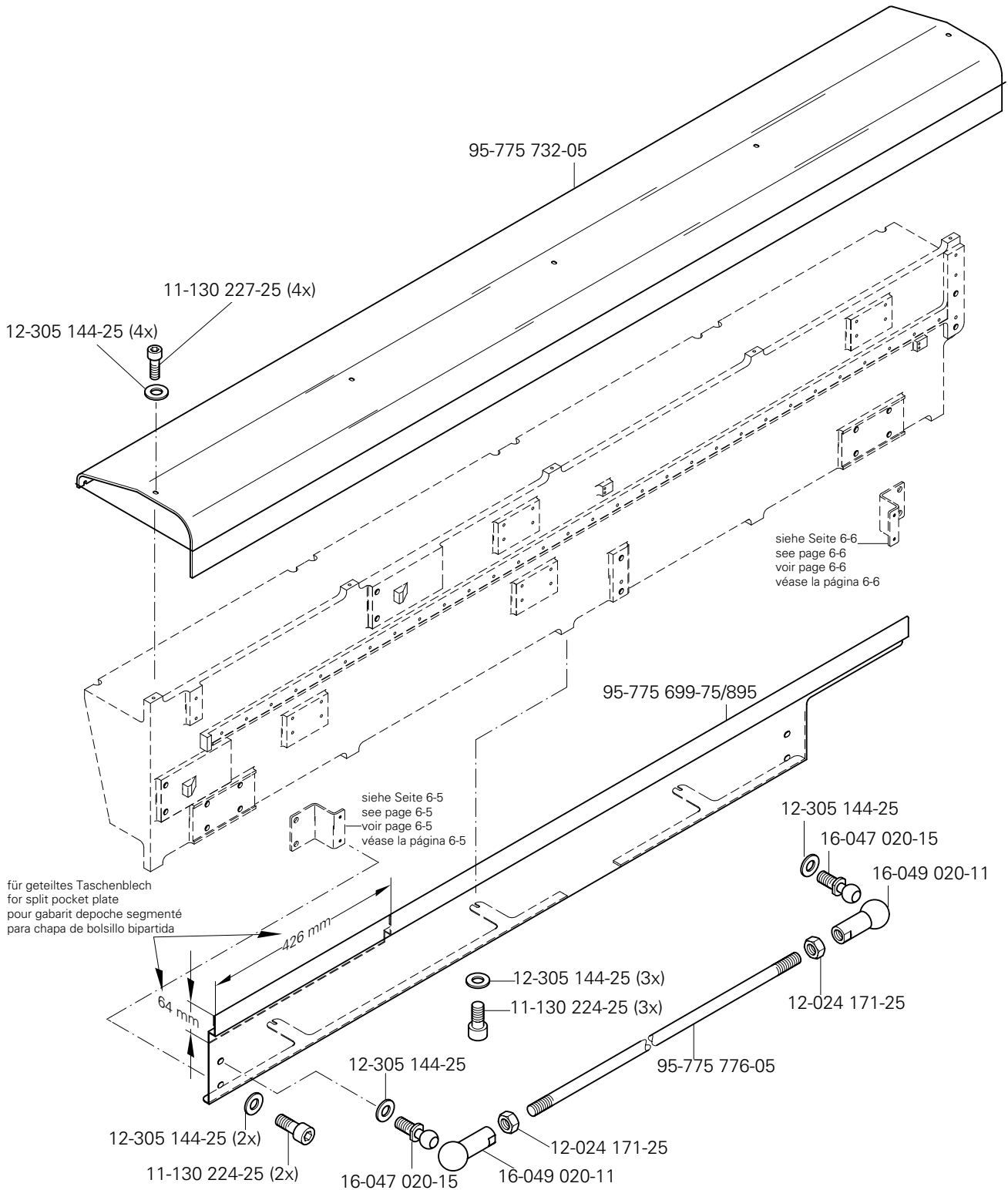
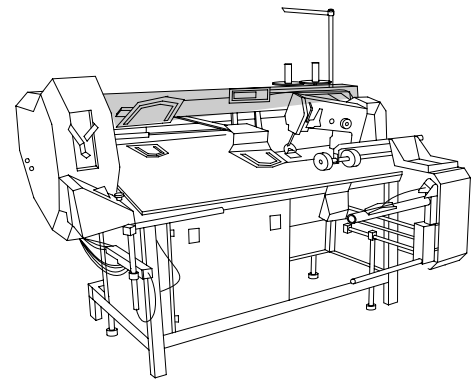

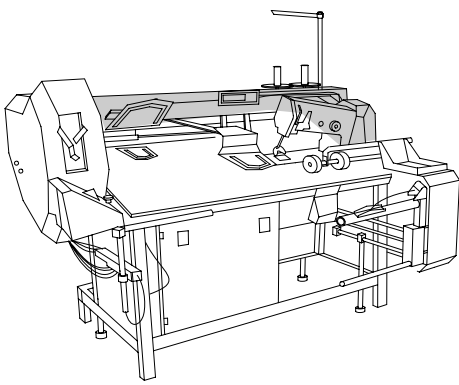

siehe Seite 11-3
 see page 11-3
 voir page 11-3
 véase la página 11-3

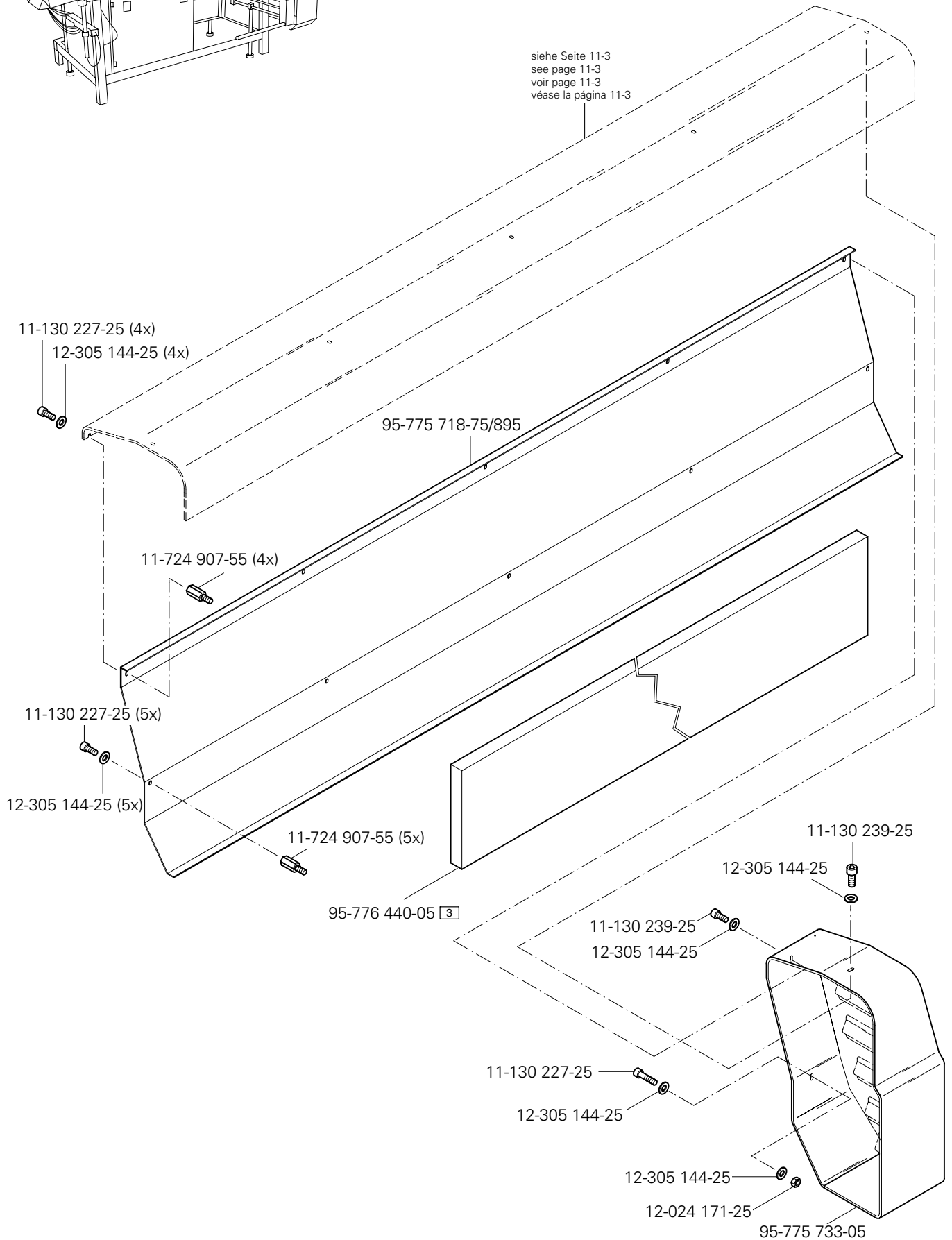

siehe Kapitel 2 Erläuterung der Schlüsselzeichen
 see chapter 2 Explanation of key markings
 voir le chap. 2 Explication des symboles
 véase el Cap. 2 Explicaciones de los signos clave

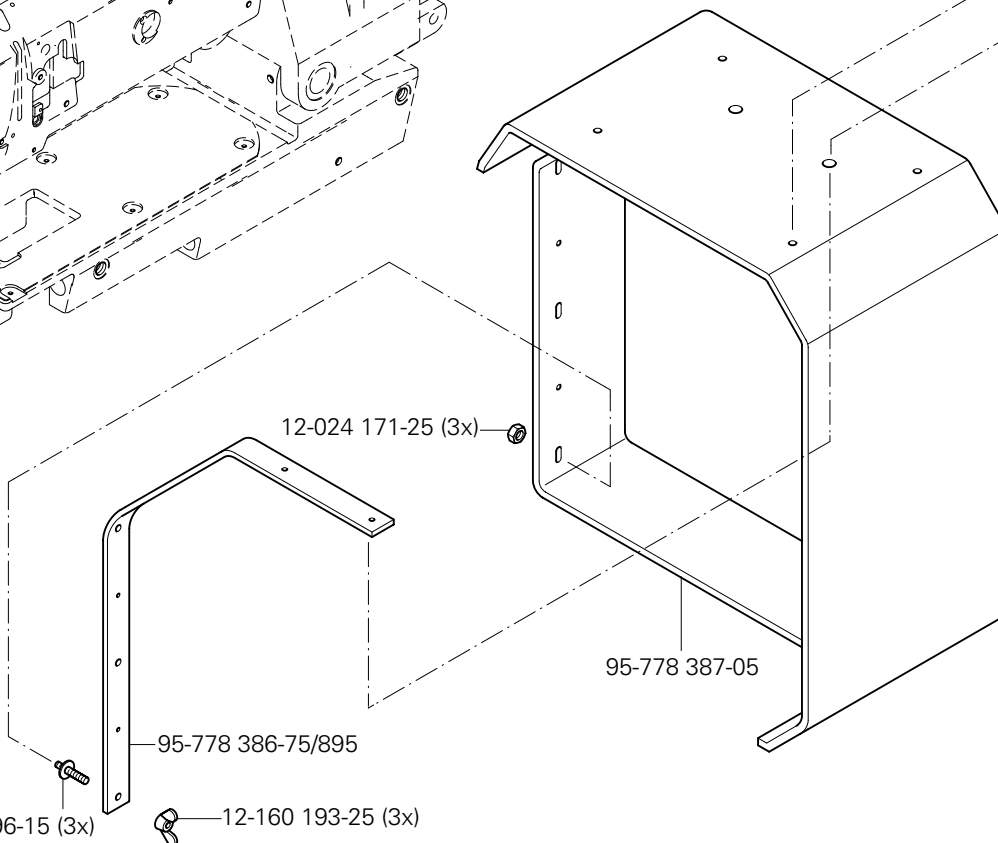
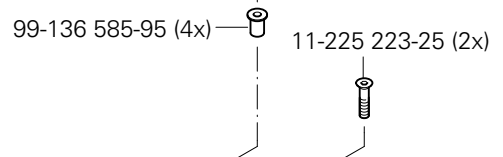
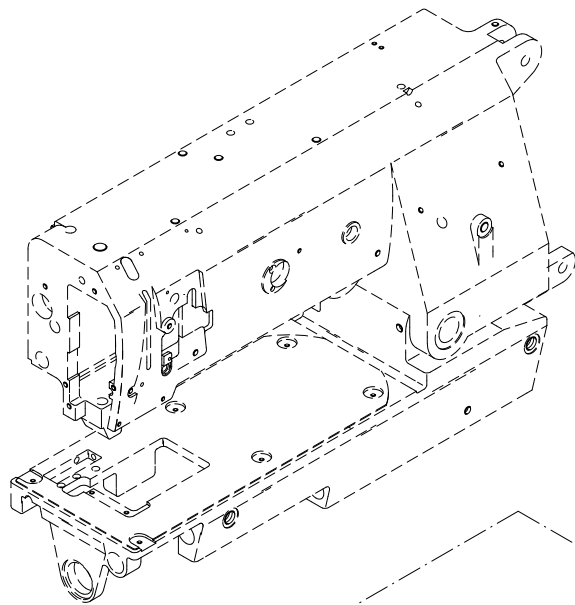
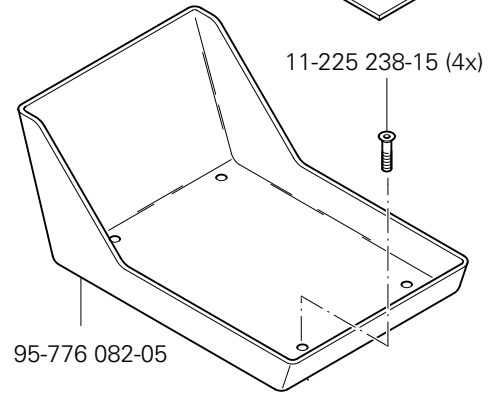
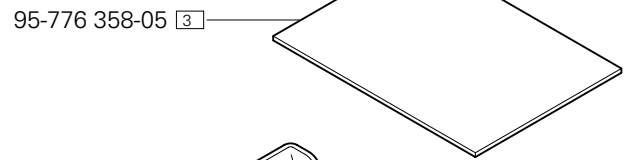
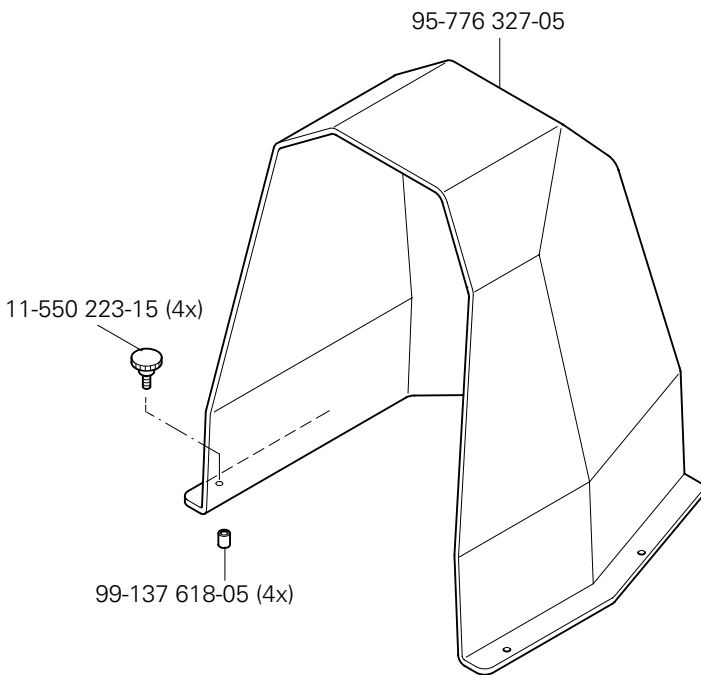
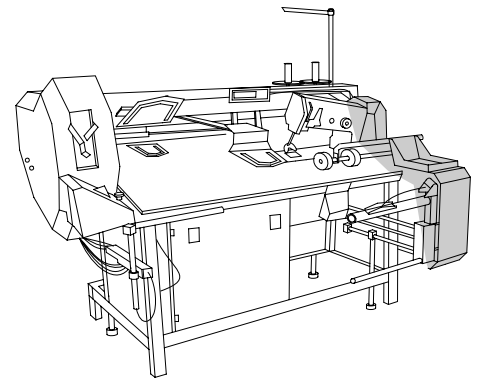

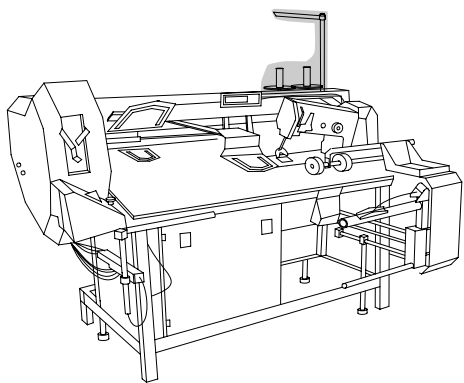

Garnrollenständer
 Reel stands
 Porte-bobines
 Portacarretes

PFAFF 3588-12/021

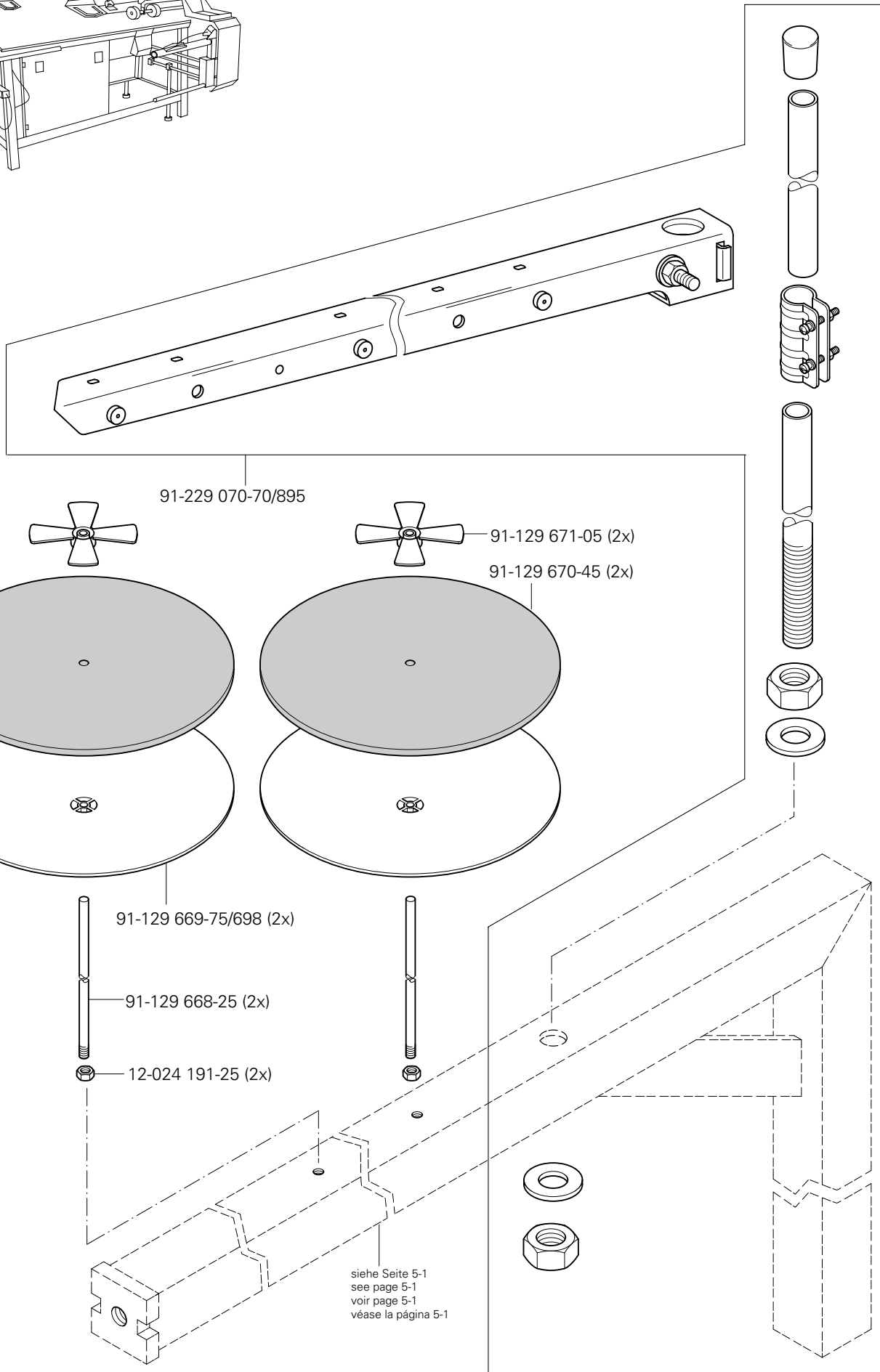

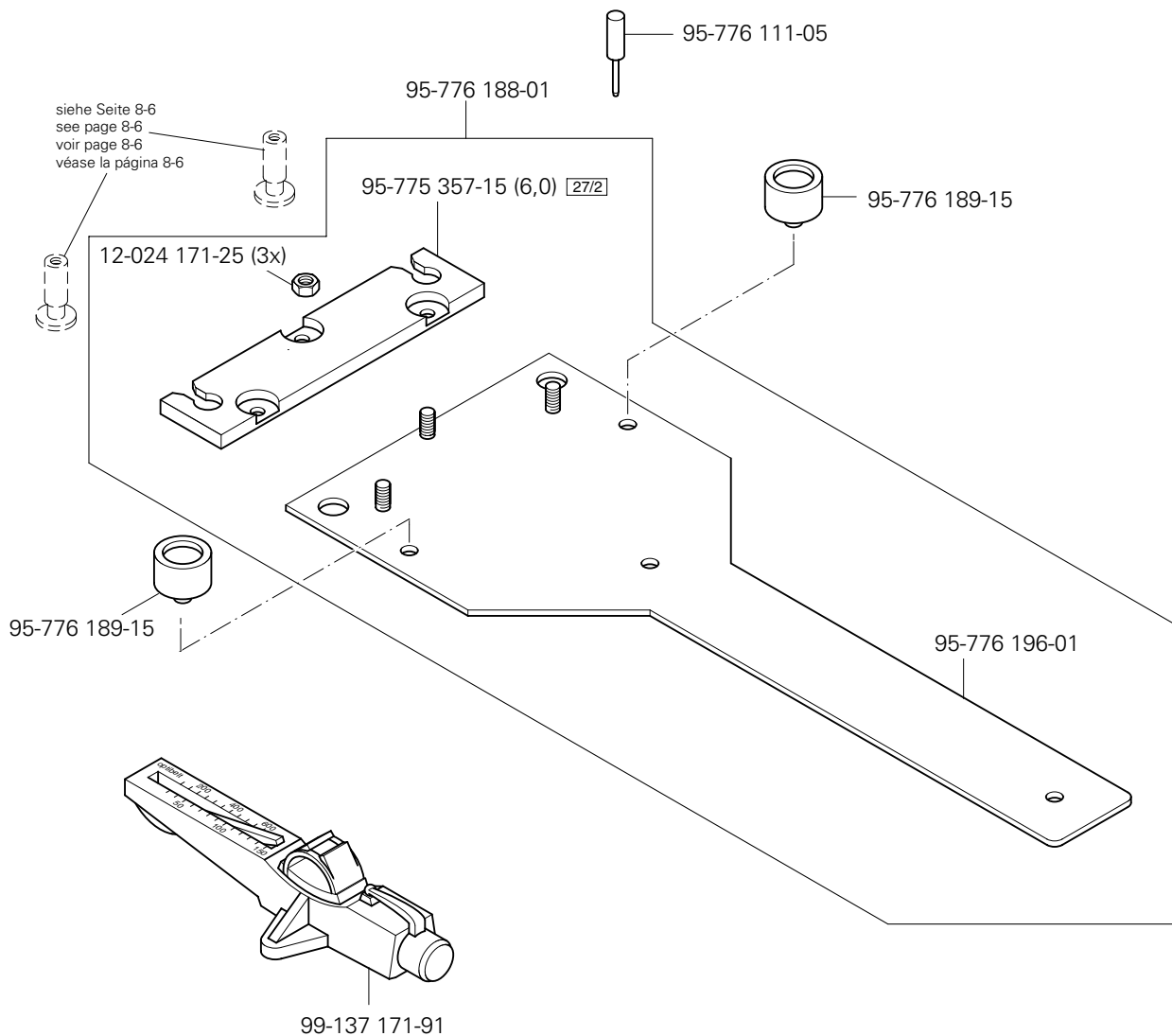
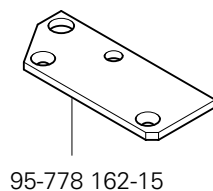
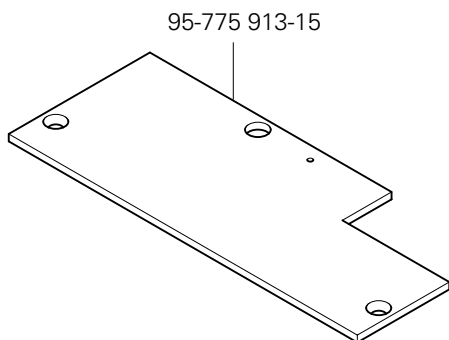
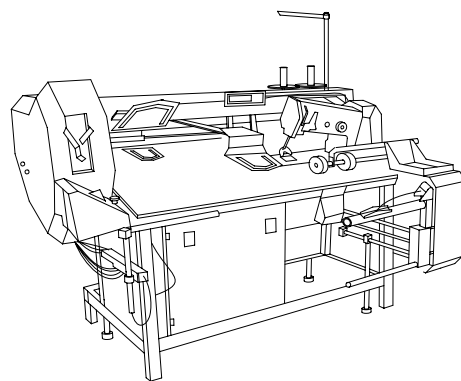

Öl Oil Huile Aceite	Mittelpunkts-Viskosität bei: Mean viscosity at: Viscosité moyenne à: Viscosidad media a:		Dichte bei: Density of: Densité à: Densidad a:		Bestellnummer für Behälter mit: Part number for can with: Numéro de commande pour récipients avec: Número de pedido para recipientes con:		
	°C	mm ² /s	°C	g/cm ³ (g/ml)	1 Liter 1 Litre 1 Litro		
28-011 201-44	40	22,0	15	0,865	91-129 917-91		

Fett Grease Graisse Grasa	Penetration Penetration Pénétration Penetración	Tropfpunkt Drip-point Point de suintement Punto de goteo	Bestellnummer für Behälter mit: Part number for can with: Numéro de commande pour récipients avec: Número de pedido para recipientes con:		
			mm/10	°C	0,25 kg 0,5 kg 1 kg
28-011 202-05					28-011 202-05
28-011 202-10		185			28-011 202-10
28-011 202-43	375-405	150		28-011 202-43	
28-011 202-47	220-250	185			28-011 202-47

Reinigungsmittel Cleansing agent Agents de nettoyage Limpiadores	Bestellnummer für Behälter mit: Part number for can with: Numéro de commande pour récipients avec: Número de pedido para recipientes con:		
	240 ml		
Isoprophyl-Alkohol	95-665 735-91		

15.01

Höhenverstellung für Gestell PFAFF 3588-12/021
 Vertical adjustment for frame
 Réglage de la hauteur du bâti
 Regulación de la altura del bastidor

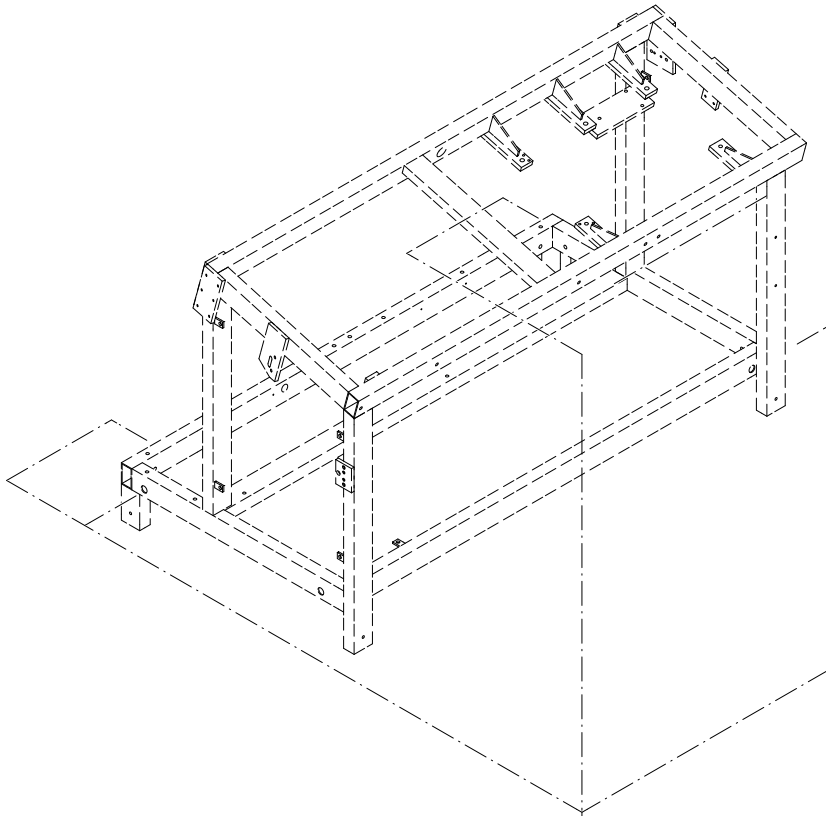
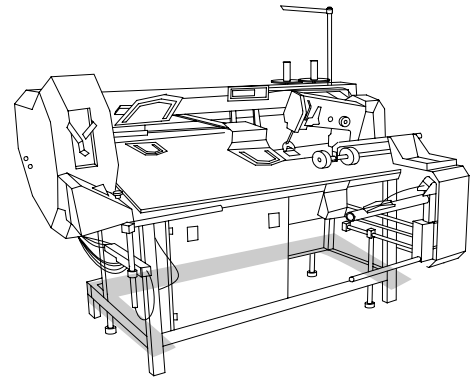

95-775 520-91 (3x)

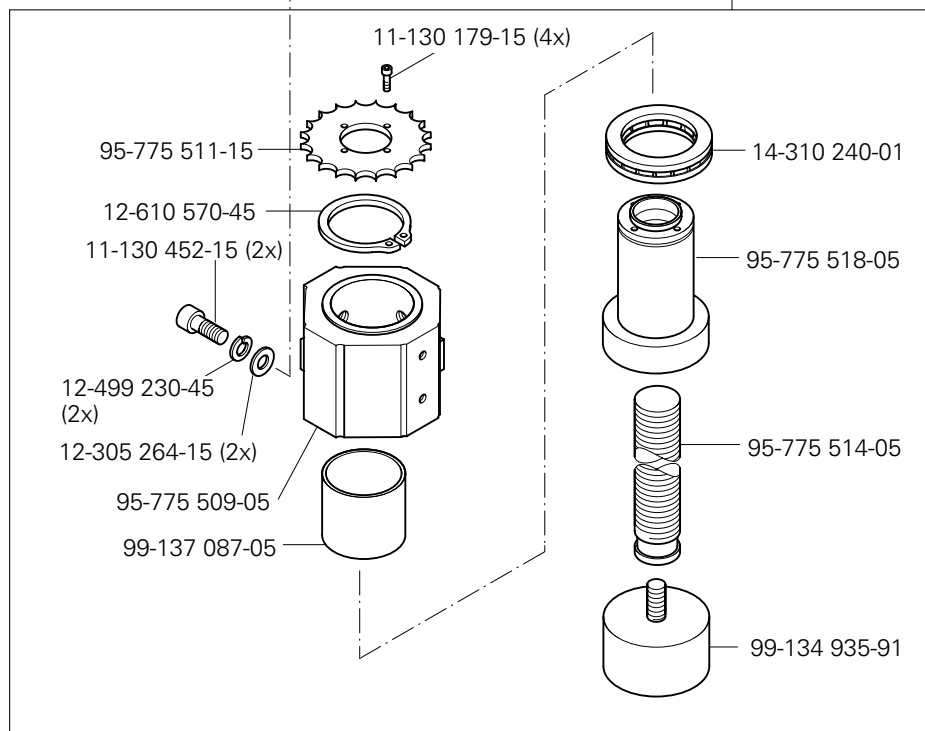

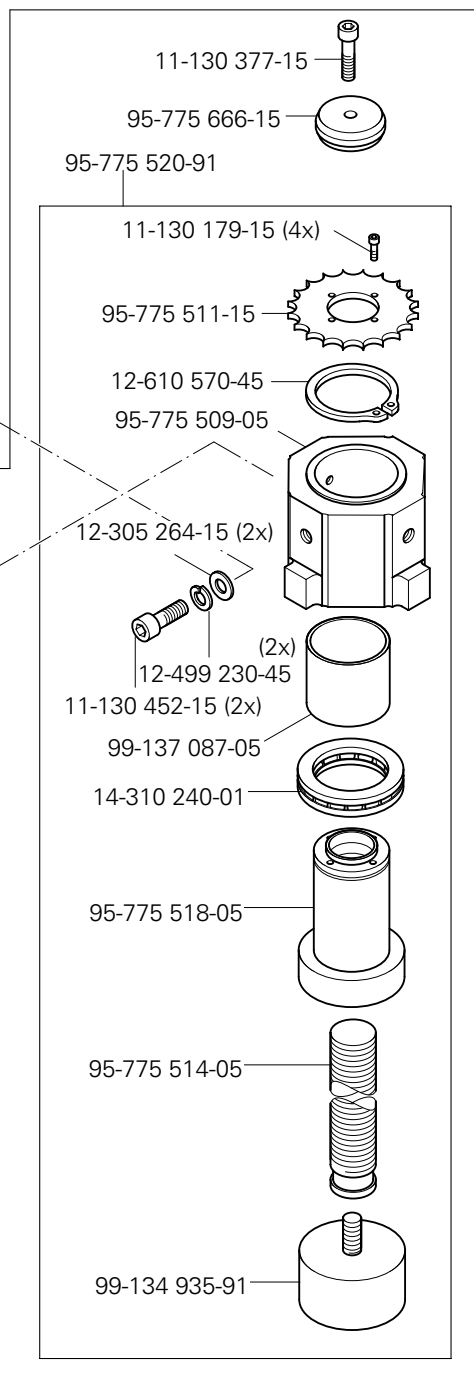
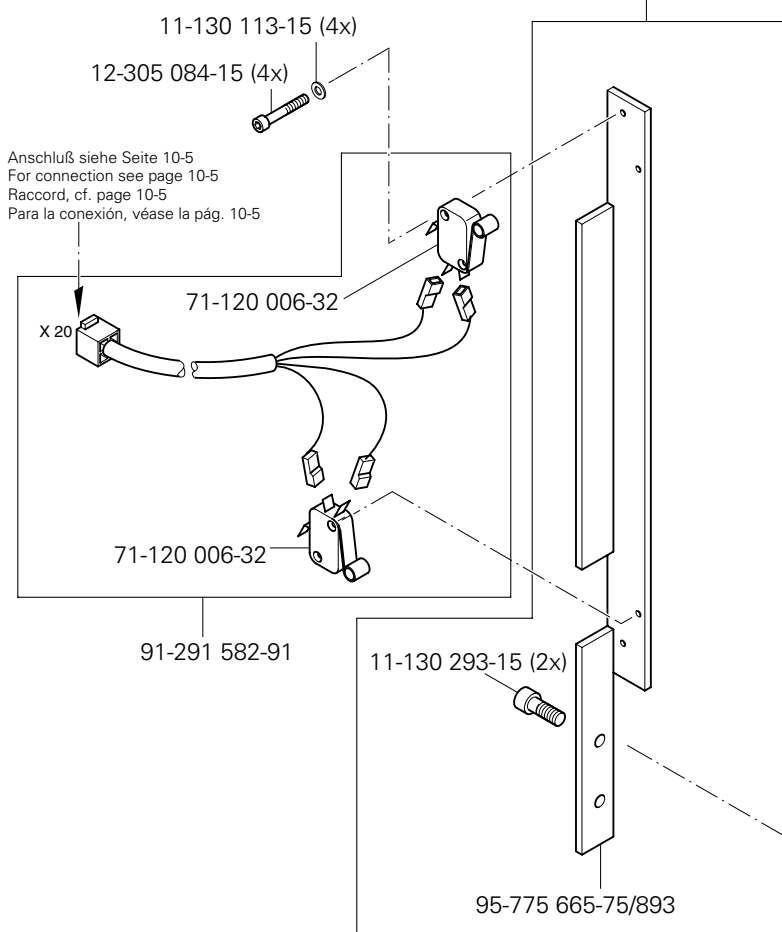
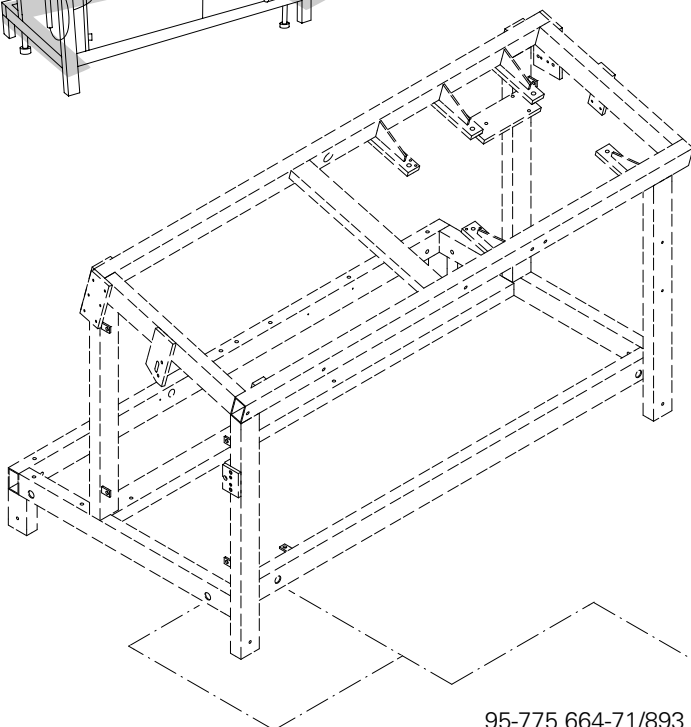
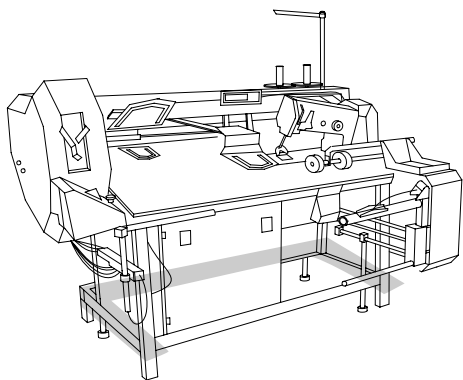

15.01

Höhenverstellung für Gestell PFAFF 3588-12/021
 Vertical adjustment for frame
 Réglage de la hauteur du bâti
 Regulación de la altura del bastidor

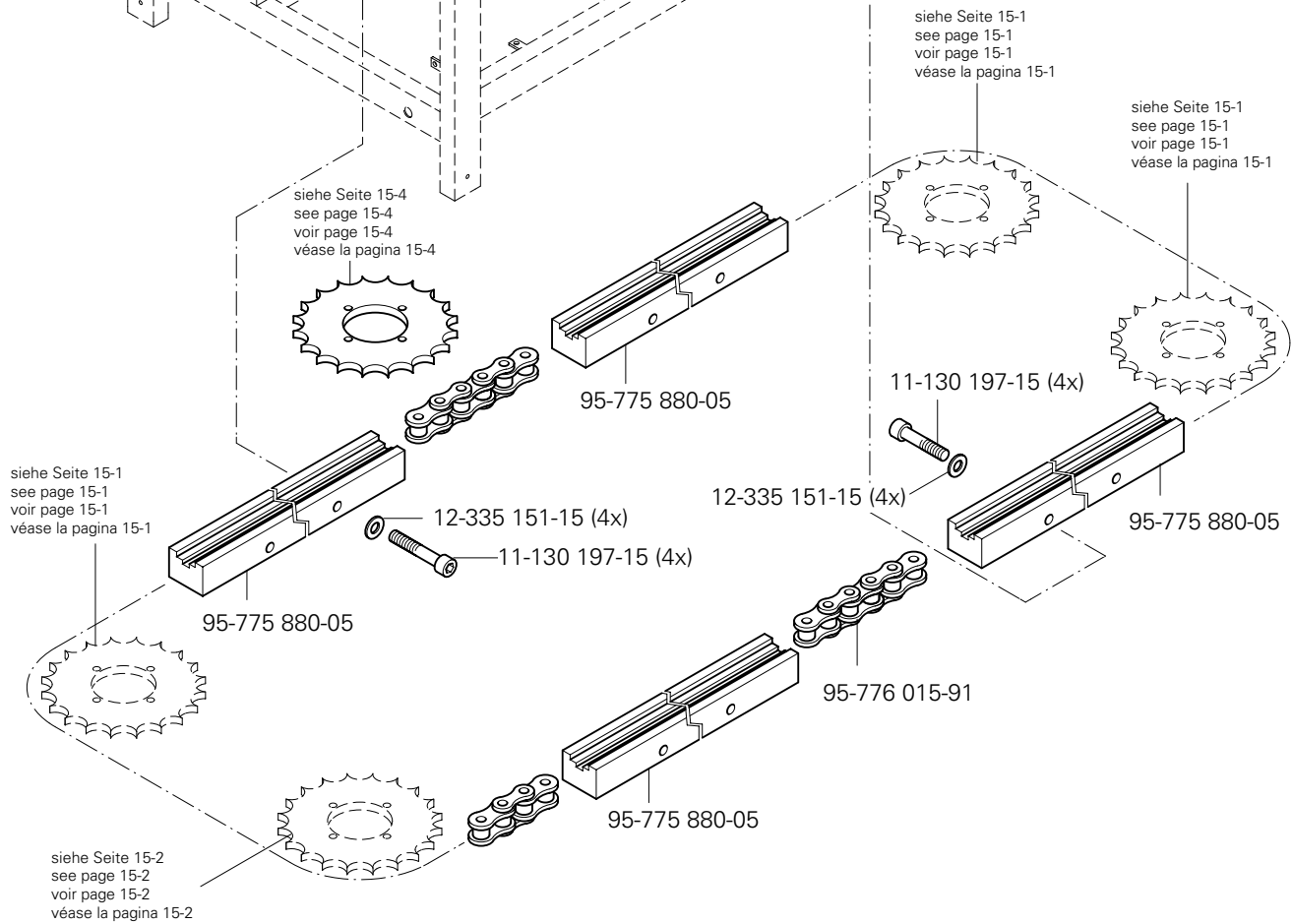
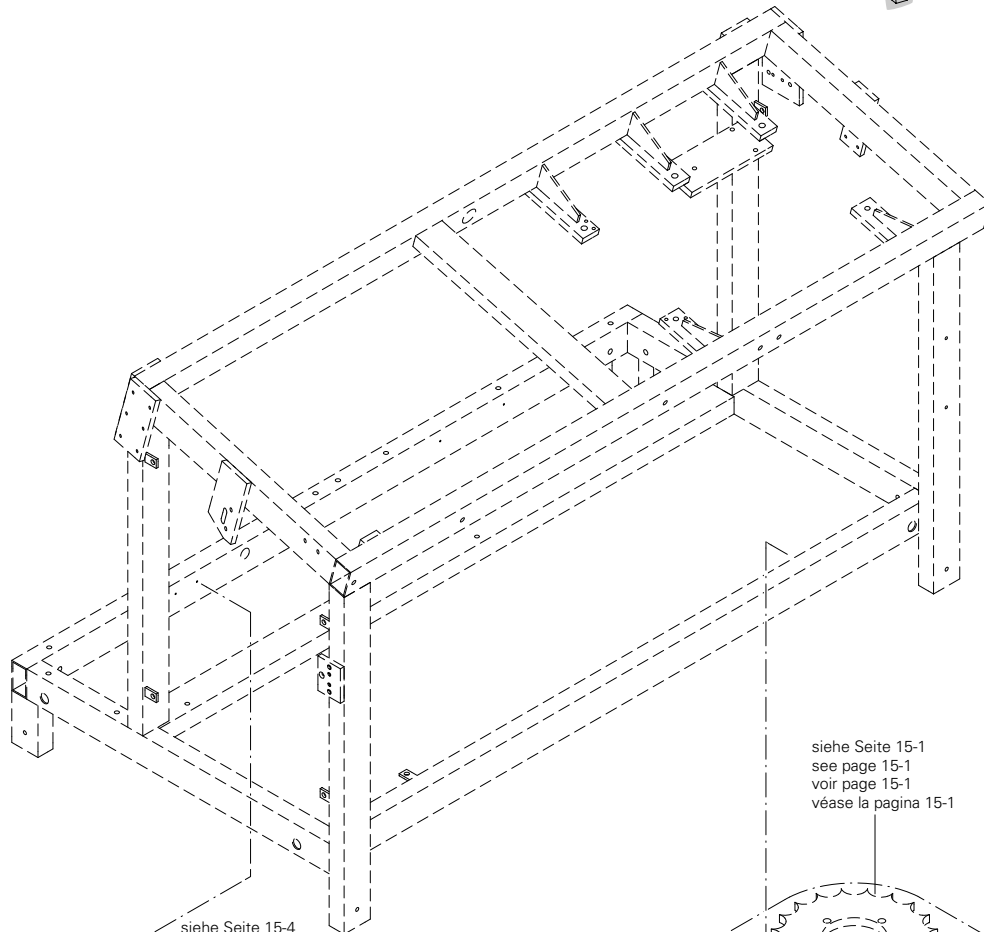
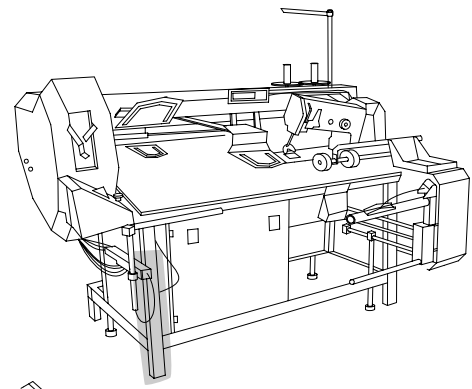

Höhenverstellung für Gestell
 Vertical adjustment for frame
 Réglage de la hauteur du bâti
 Regulación de la altura del bastidor

PFAFF 3588-12/021

15.01

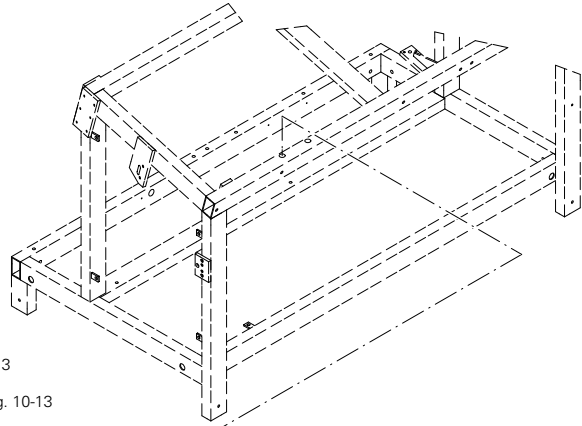
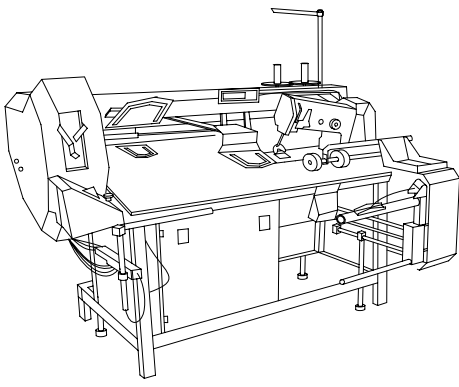

Anschluß siehe Seite 10-13
 For connection see page 10-13
 Raccord, cf. page 10-13
 Para la conexión, véase la pág. 10-13

91-291 583-91

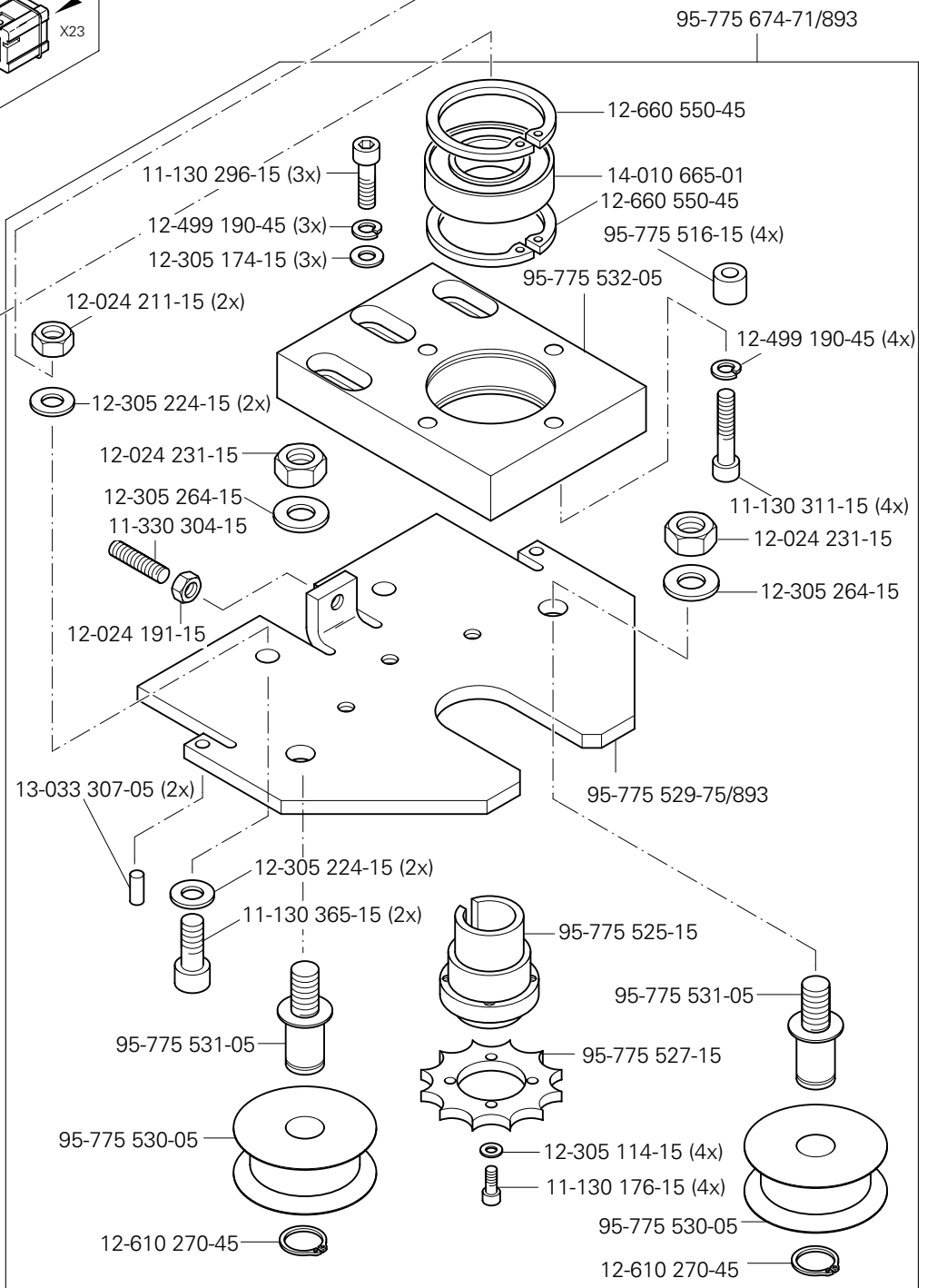
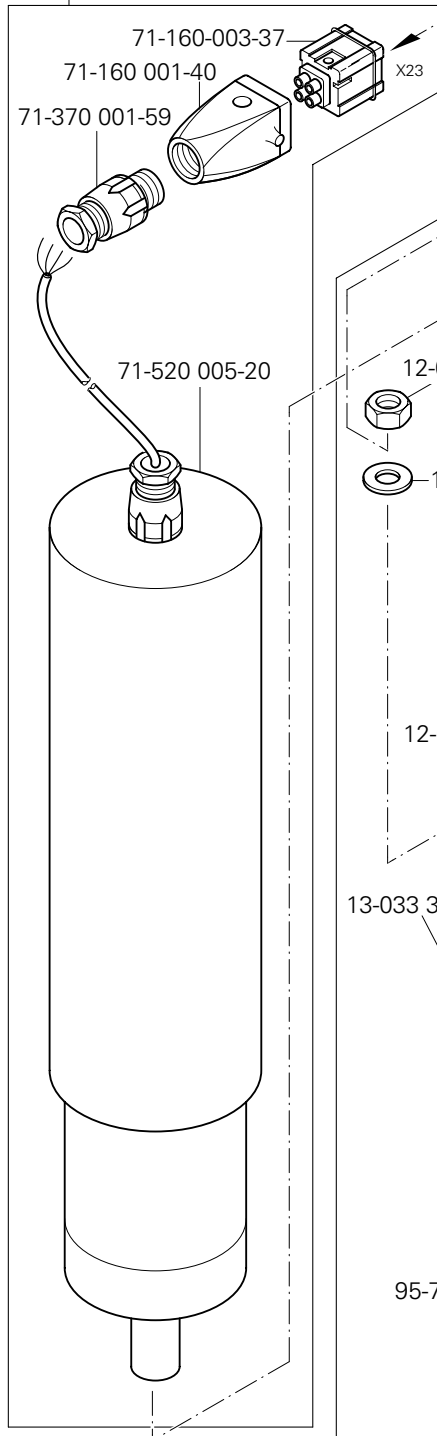

15.01

Höhenverstellung für Gestell PFAFF 3588-12/021
 Vertical adjustment for frame
 Réglage de la hauteur du bâti
 Regulación de la altura del bastidor

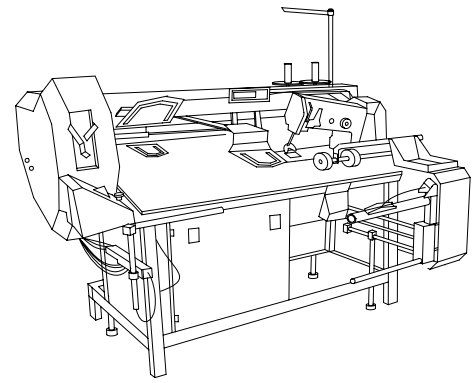

95-775 851-75/893

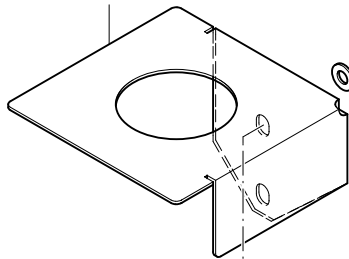

11-130 293-15 (2x)
 12-305 174-15 (2x)

95-775 851-75/893

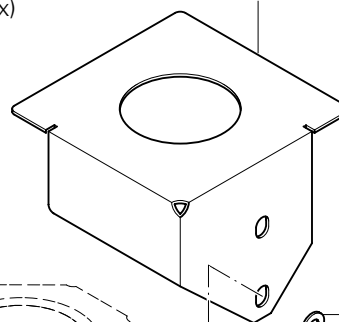

12-305 174-15 (2x)

11-130 293-15 (2x)

siehe Seite 15-1
 see page 15-1
 voir page 15-1
 véase la página 15-1

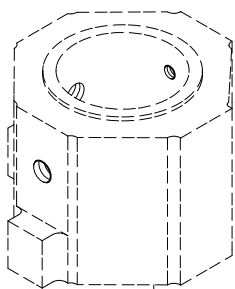

siehe Seite 15-1
 see page 15-1
 voir page 15-1
 véase la página 15-1

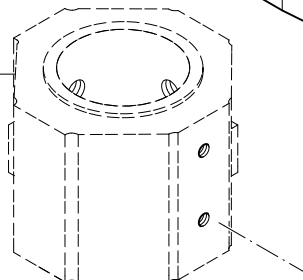

11-130 293-15 (2x)

12-305 174-15 (2x)

95-775 851-75/893

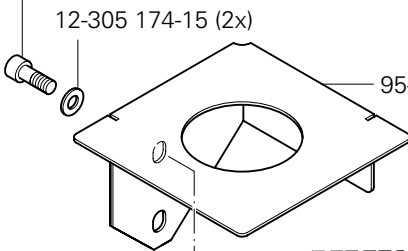

siehe Seite 15-2
 see page 15-2
 voir page 15-2
 véase la página 15-2

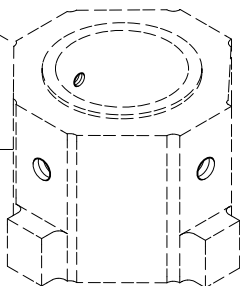

95-775 851-75/893

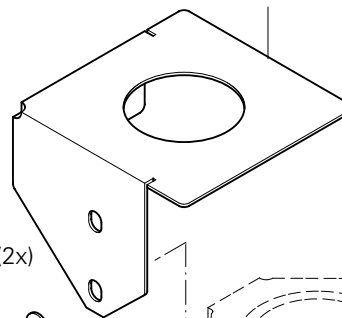

siehe Seite 15-1
 see page 15-1
 voir page 15-1
 véase la página 15-1

11-130 293-15 (2x)

12-305 174-15 (2x)

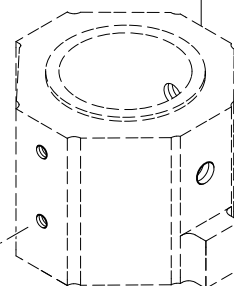

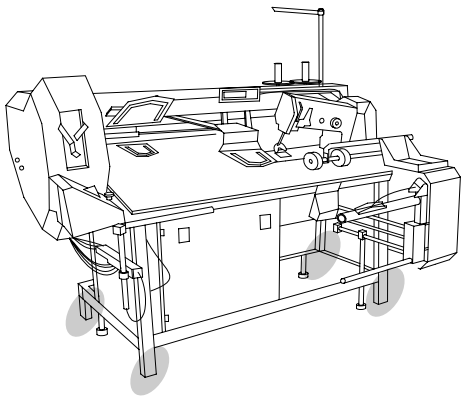

Transportrolle
 Feed roller
 Galet d'entraînement
 Rodillo el transporte

PFAFF 3588-12/021

15.02

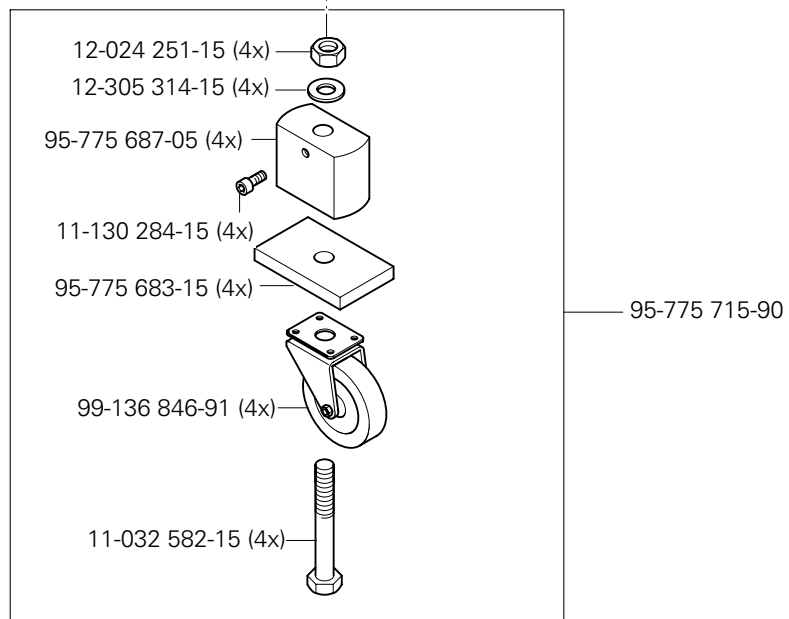
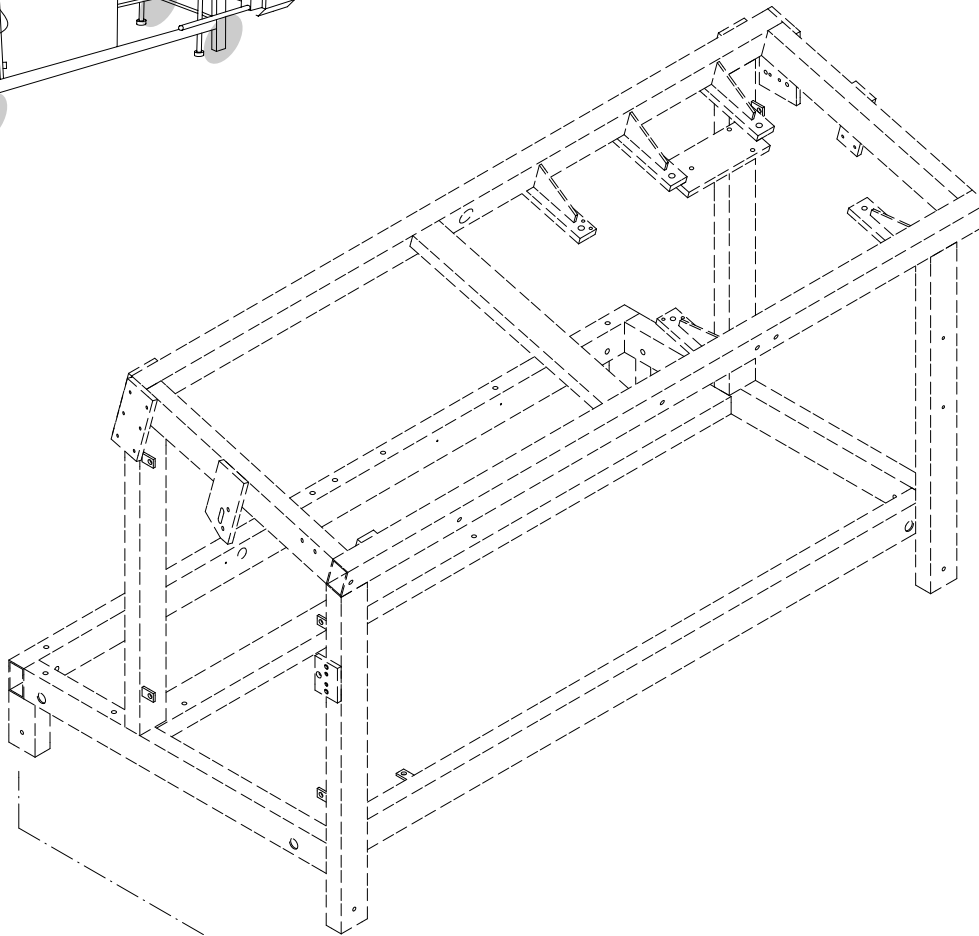

15.03

Anbausatz für Programmerkennung
 Add-on kit for program identification
 Kit pour reconnaissance de programme
 Kit para identificación del programa PFAFF 3588-12/021

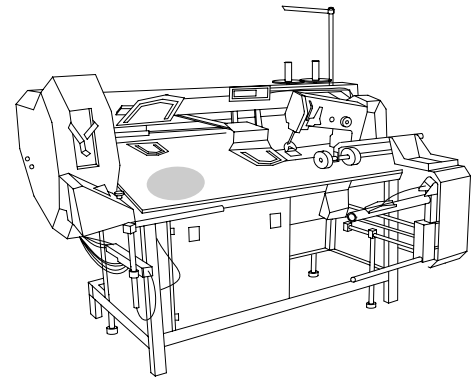

siehe Seite 15-14
 see page 15-14
 voir page 15-14
 véase la página 15-14

siehe Seite 4-1
 see page 4-1
 voir page 4-1
 véase la página 4-1

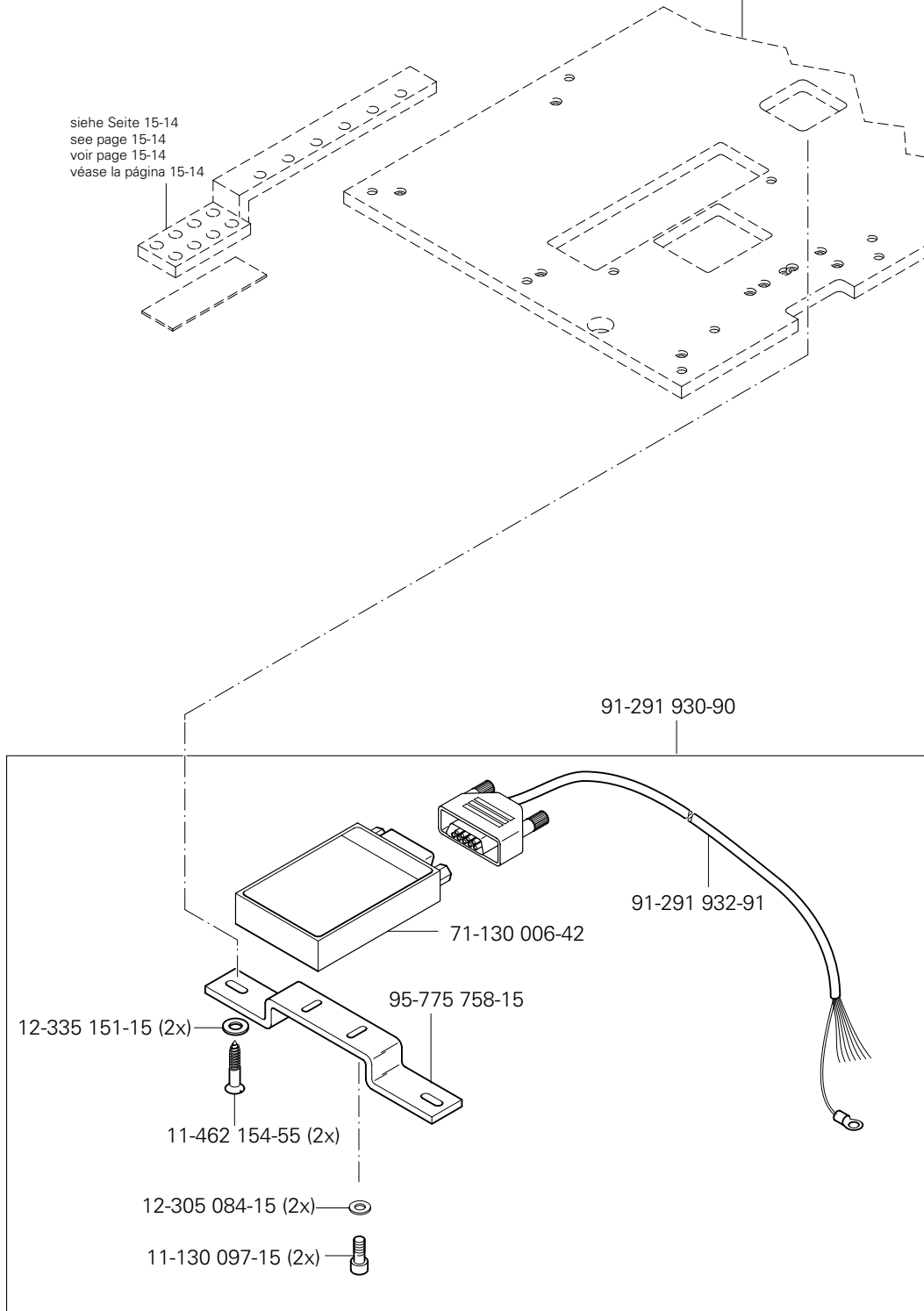

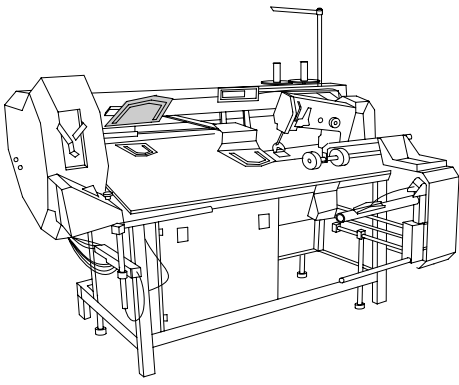

Anbausatz für Magnet
 Add-on kit for solenoid
 Jeu de pièces adaptables pour electro-aimant
 Juego de piezas acoplables para Electroimán

PFAFF 3588-12/021 **15.04**

91-291-920-90

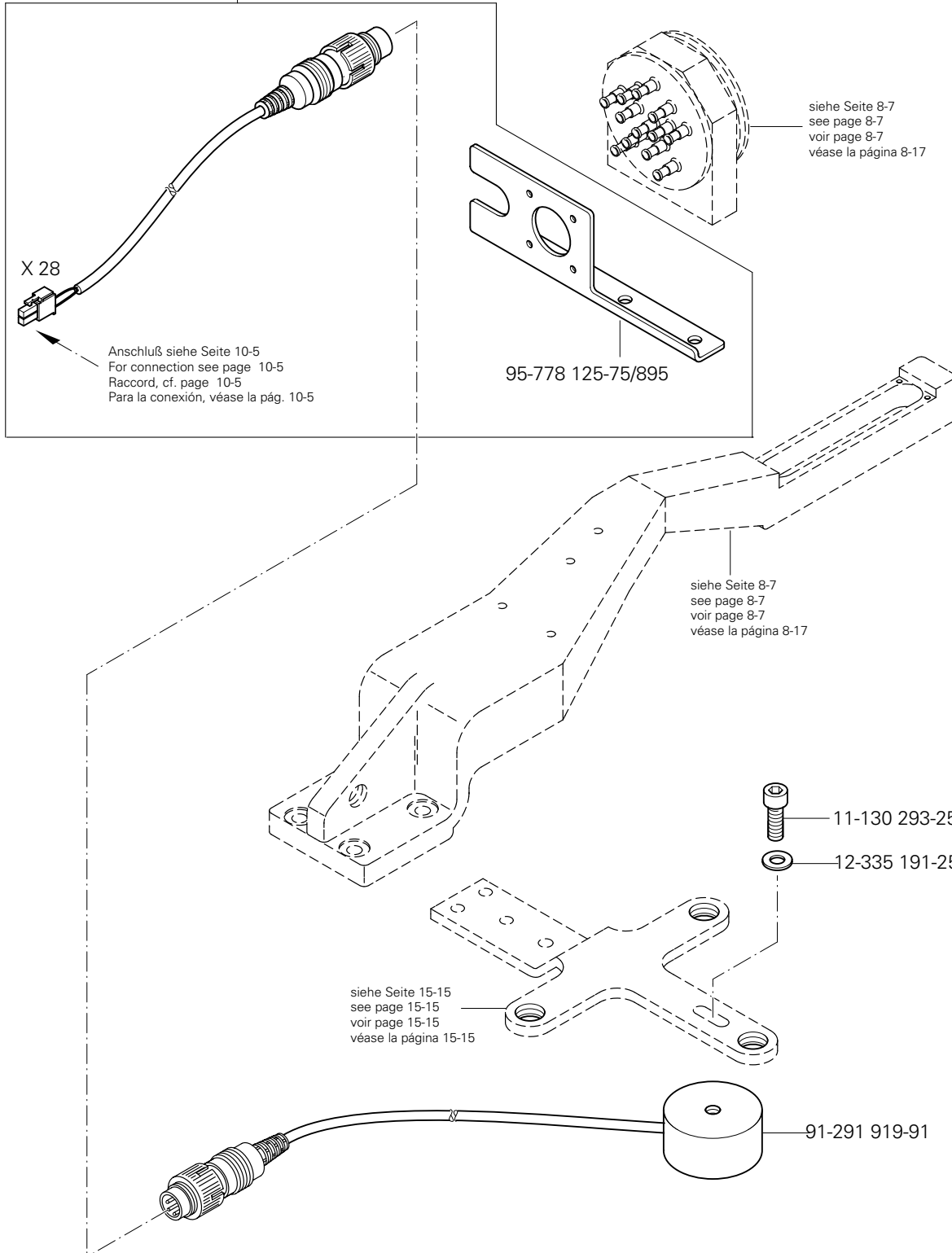

15.05

Bausatz für breiten Saum
 Kit for wide hem
 Kit pour ourlet large
 Juego de montaje para dobladillo ancho PFAFF 3588-12/021

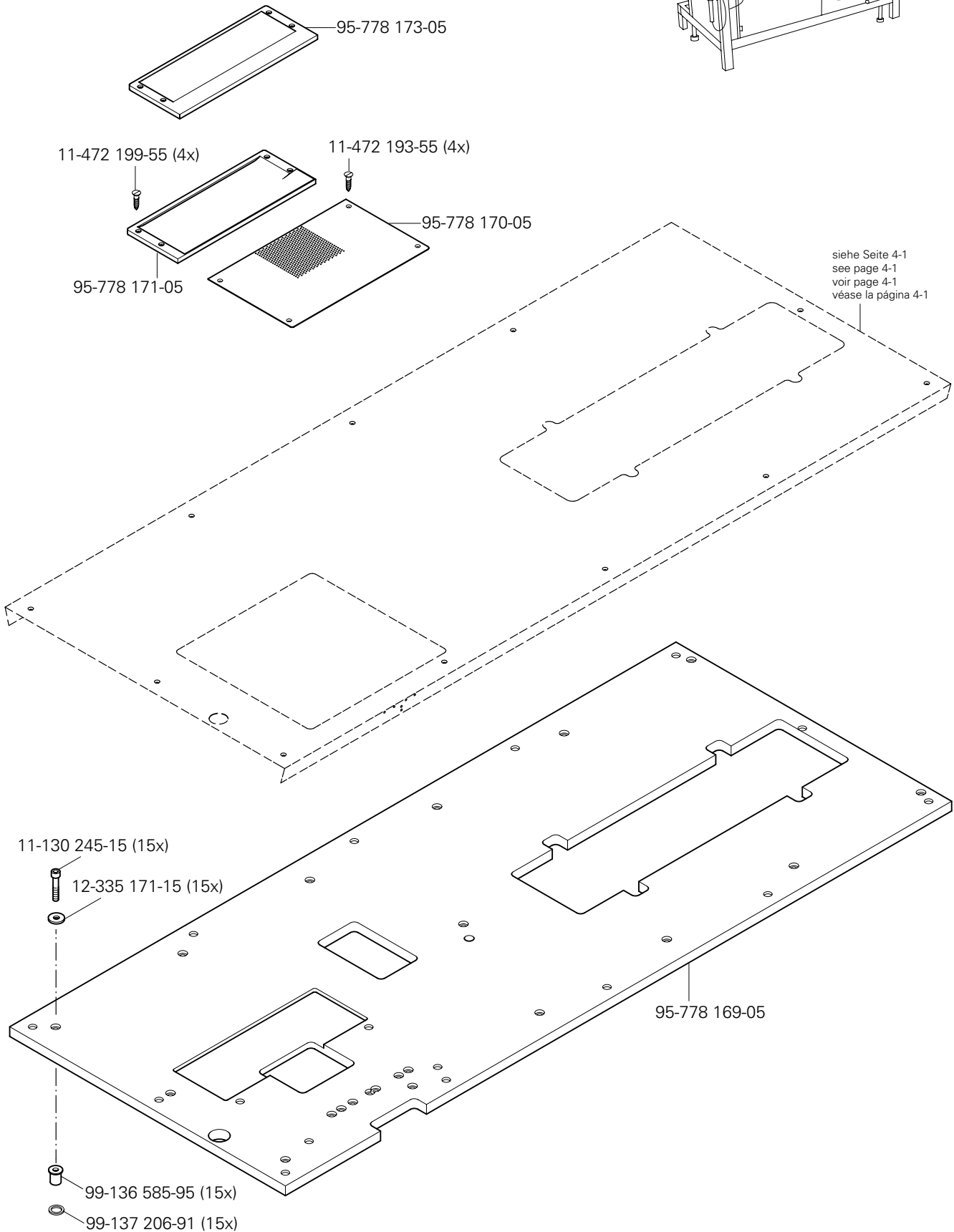
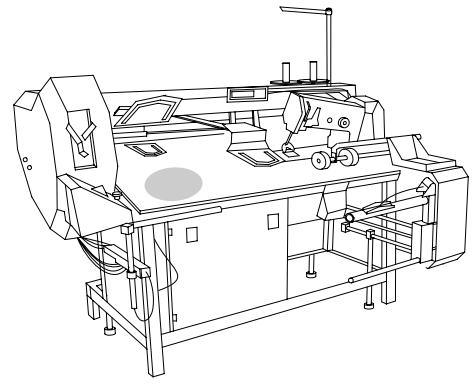

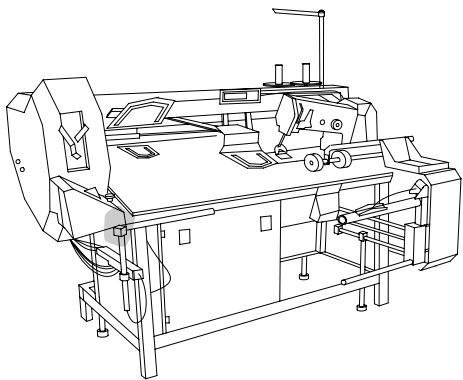

Anlagebox
Collection box
Boîte prince
Caja de apilado

PFAFF 3588-12/021

15.06

95-778 481-91

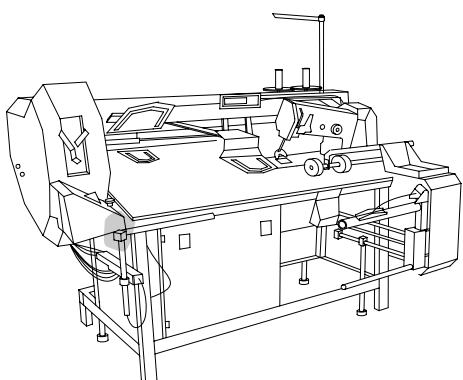
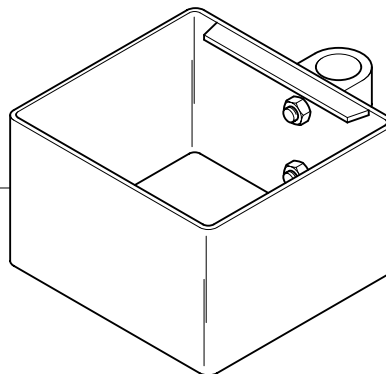

Halter für Laser
Laser part set holder
Support à laser
Sujeción de laser

PFAFF 3588-12/021

15.07



95-778 475-05

95-778 470-71/893

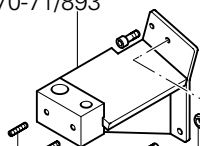

11-330 280-15 (2x)

11-130 341-15

12-024 191-25

11-130 224-15 (2x)

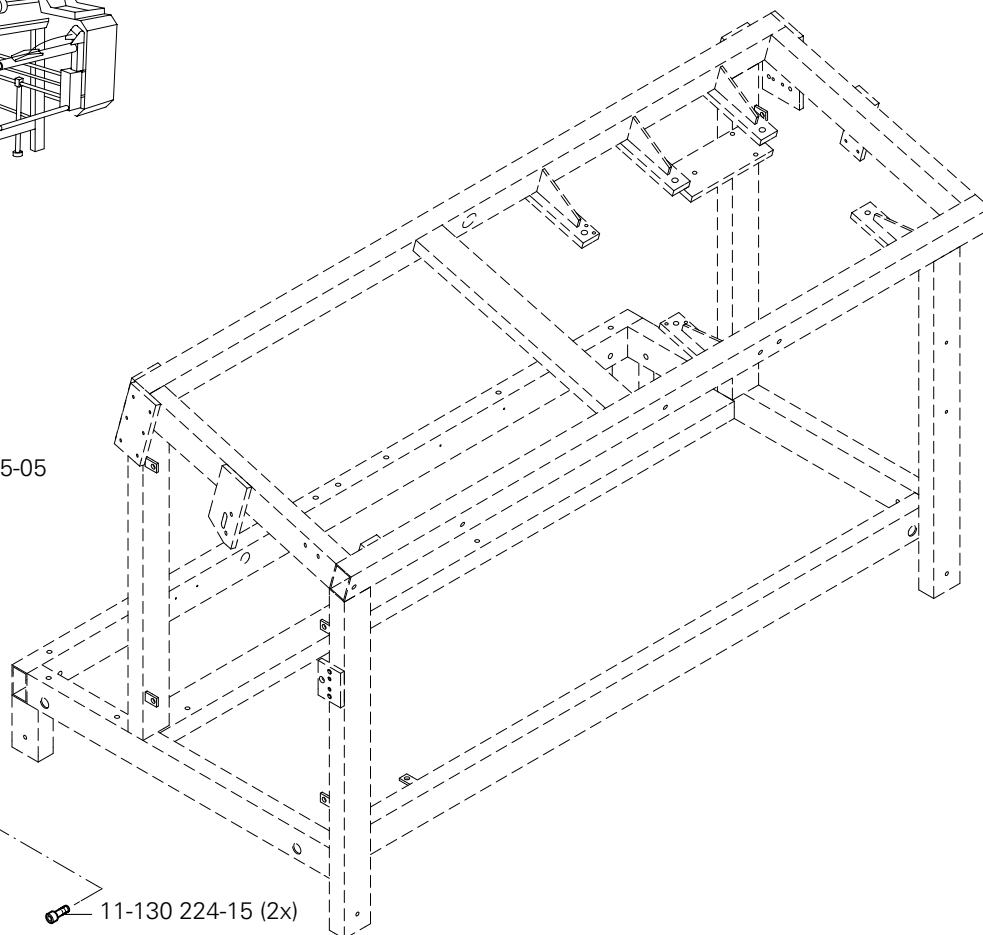

15.08

Fußtaster mit Leitung
Foot control with cord
Interrupteur au pied, avec câble
Interruptor de pie, con cabbe PFAFF 3588-12/021

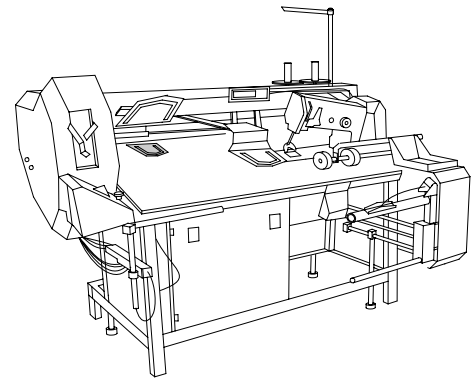

95-776 304-71/893

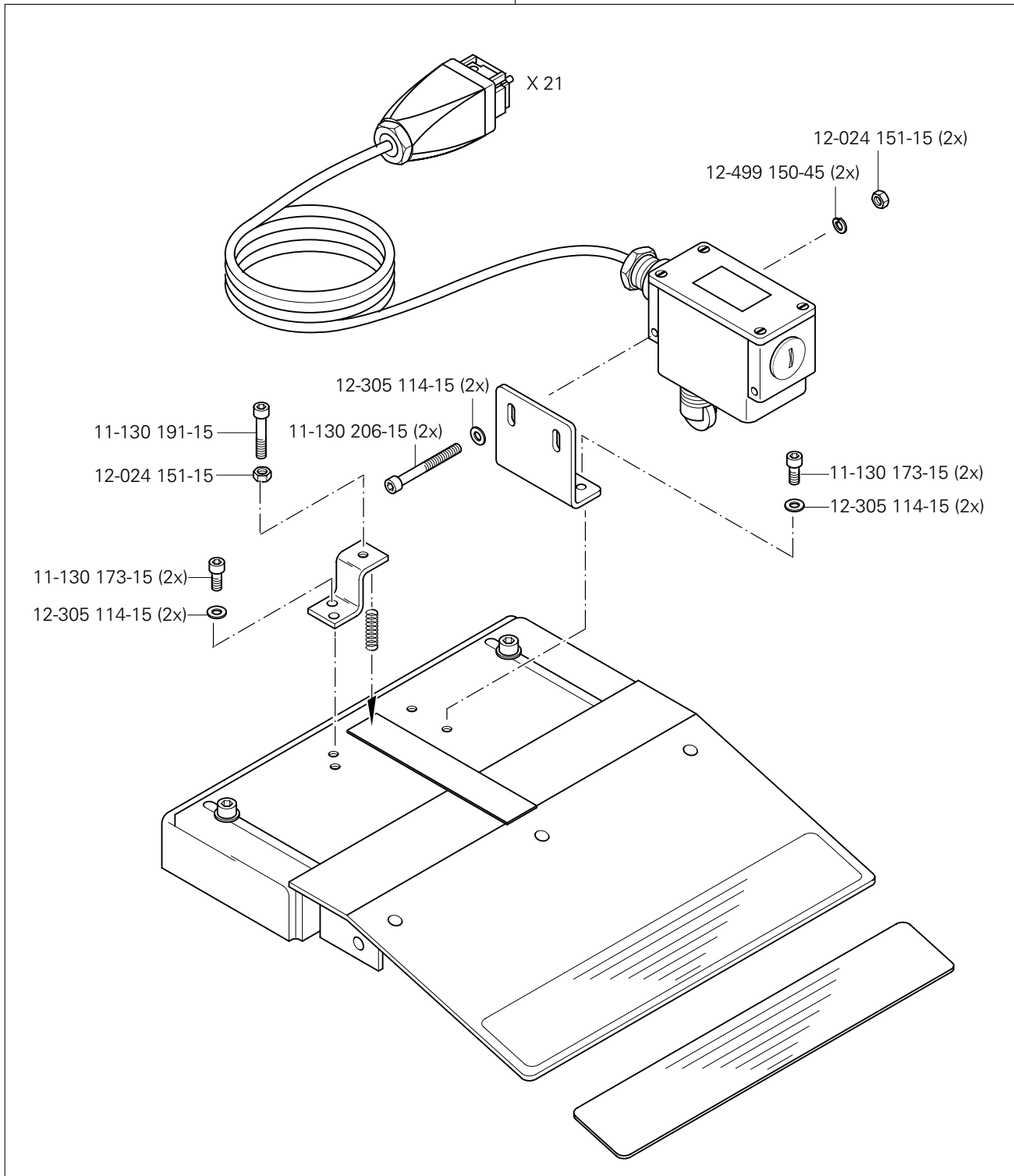

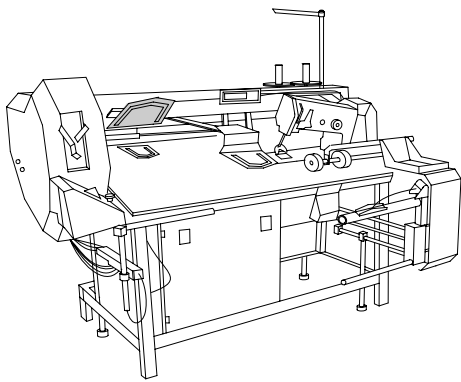

Teilesatz vollst.(Standardausführung)
 Part set assy (Standard version)
 Jeu de pièces comp. (version standard)
 Juego de piezas compl. (Tpo estándar)

PFAFF 3588-12/021 **15.09**

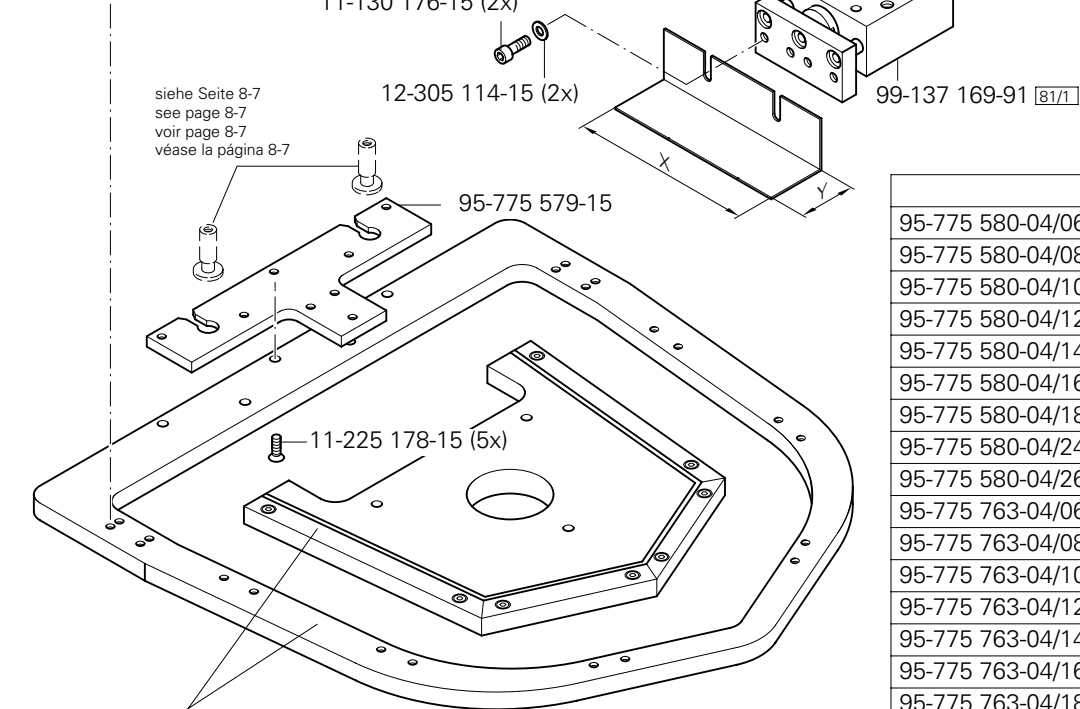
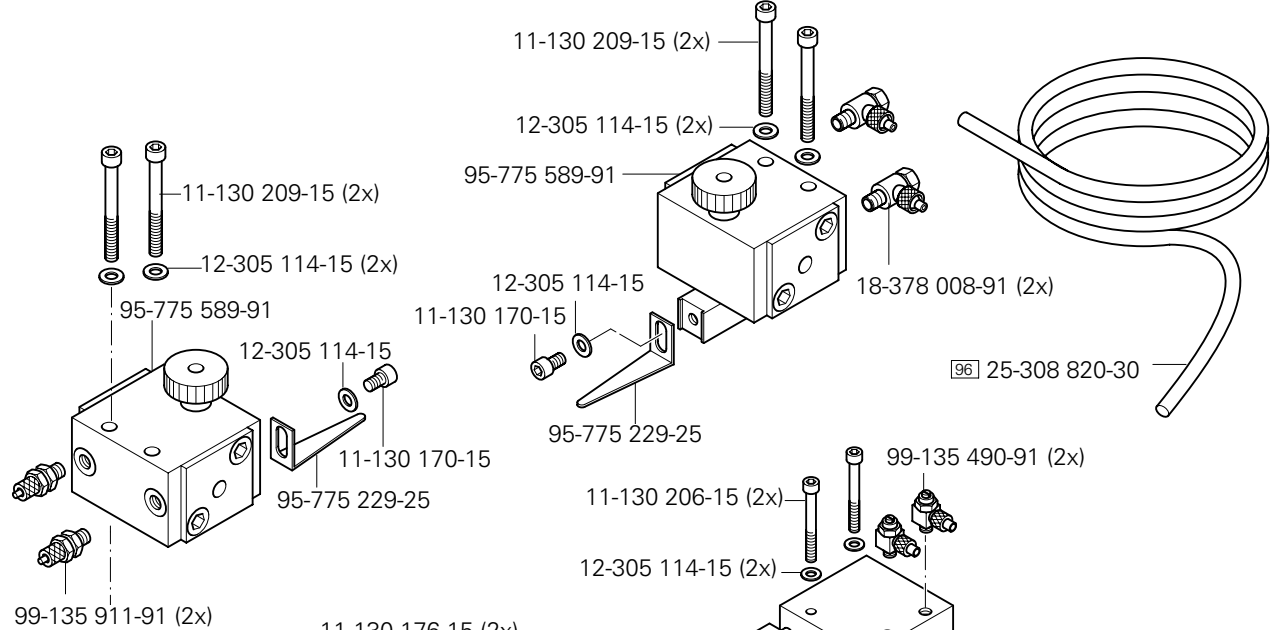
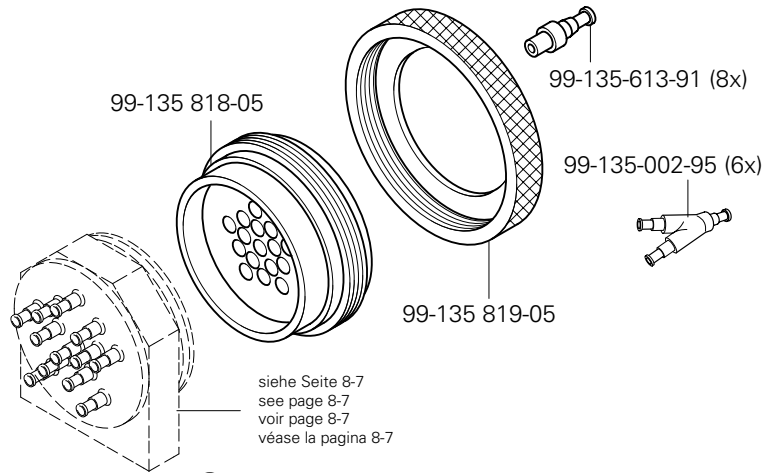

Bei Bestellung bitte die Nummer auf dem Stempel angeben
 In your order please quote the number on the die
 Prière d'indiquer à la commande le numéro sur le tampon
 En el pedido, se ruega indicar el número en el sello.

	X	Y
95-775 580-04/060	60mm	29 mm
95-775 580-04/080	80mm	29 mm
95-775 580-04/100	100mm	29 mm
95-775 580-04/120	120mm	29 mm
95-775 580-04/140	140mm	29 mm
95-775 580-04/160	160mm	29 mm
95-775 580-04/180	180mm	29 mm
95-775 580-04/240	240mm	29 mm
95-775 580-04/260	260mm	29 mm
95-775 763-04/060	60mm	45 mm
95-775 763-04/080	80mm	45 mm
95-775 763-04/100	100mm	45 mm
95-775 763-04/120	120mm	45 mm
95-775 763-04/140	140mm	45 mm
95-775 763-04/160	160mm	45 mm
95-775 763-04/180	180mm	45 mm
95-775 763-04/240	240mm	45 mm
95-775 763-04/260	260mm	45 mm

☐ siehe Kapitel 2 Erläuterung der Schlüsselzeichen
 see chapter 2 Explanation of key markings
 voir le chap. 2 Explication des symboles
 véase el Cap. 2 Explicaciones de los signos clave

15.09

Teilesatz vollst. (Standardausführung)

Part set assy. (Standard version)

Jeu de pièces comp. (Version standard)

Juego de piezas compl. (Tipo estándar) PFAFF 3588-12/021

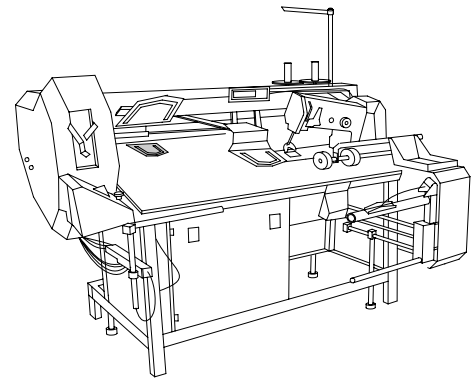

Bei Bestellung bitte die Nummer auf dem Taschenblech angeben
 In your order please quote the number on the pocket plate
 Prière d'indiquer à la commande le numéro sur la plaque métallique de poche
 En el pedido, se ruega indicar el número en la chapa de bolsillo.

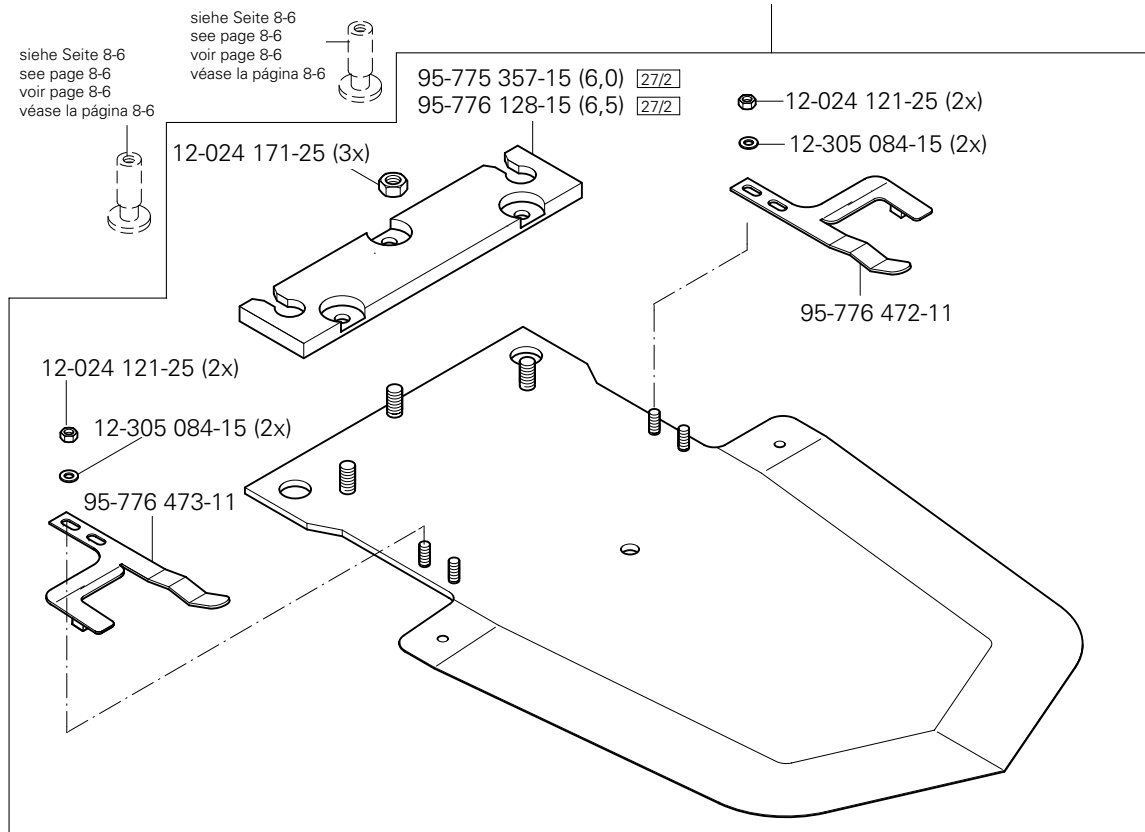

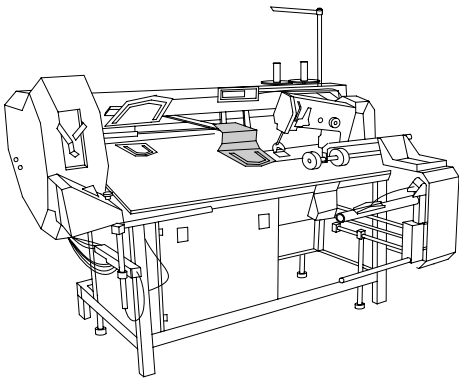

Teilesatz vollst.(Standardausführung)

Part set Assy (Standard version)

Jeu de pièces comp. (version standard)

Juego de piezas compl. (Tipo estándar) PFAFF 3588-12/021

15.09

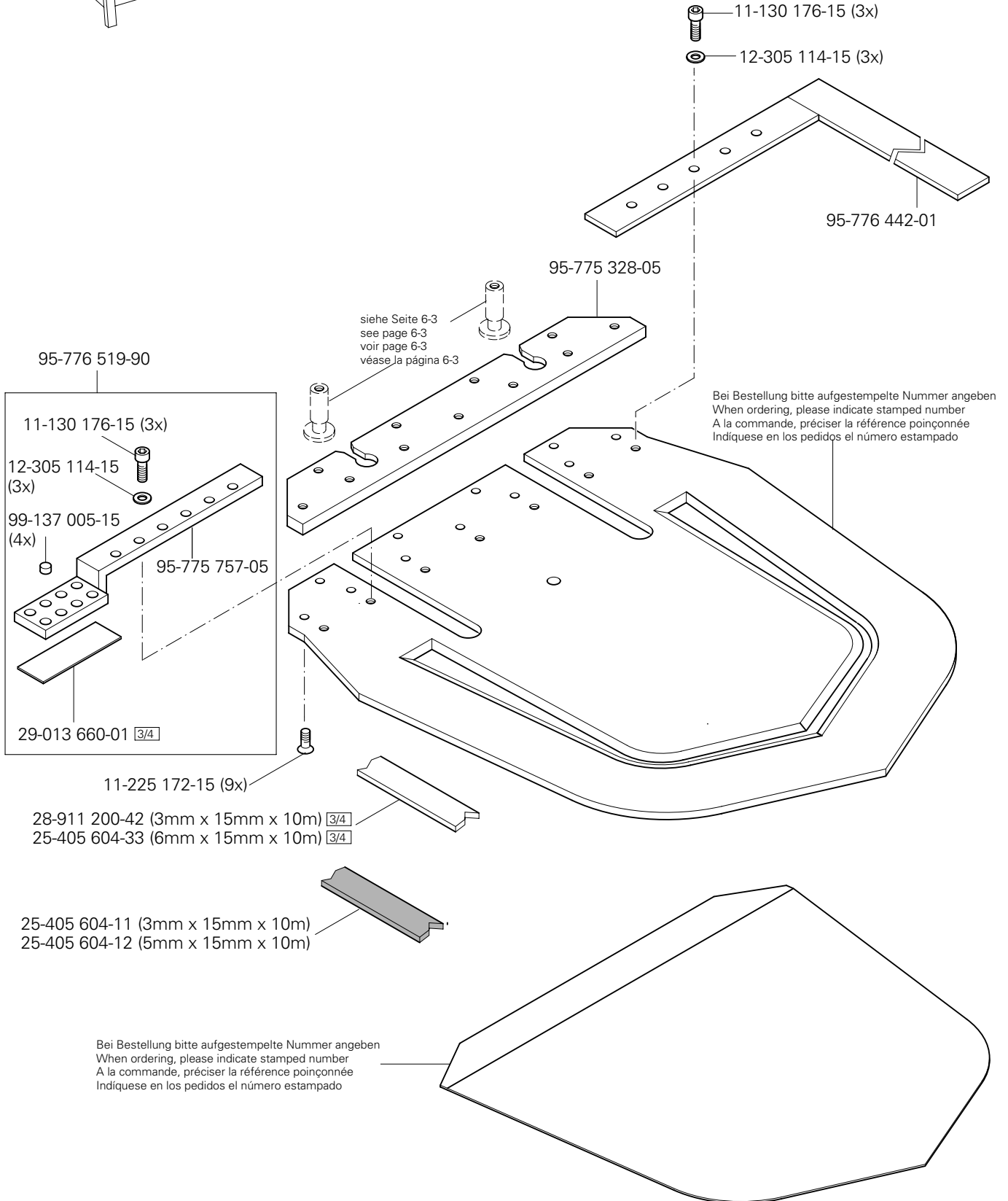

15.09

Teilesatz vollst. (Standardausführung)
 Part set assy. (Standard version)
 Jeu de pièces comp. (Version standard)
 Juego de piezas compl. (Tipo estándar) PF AFF 3588-12/021

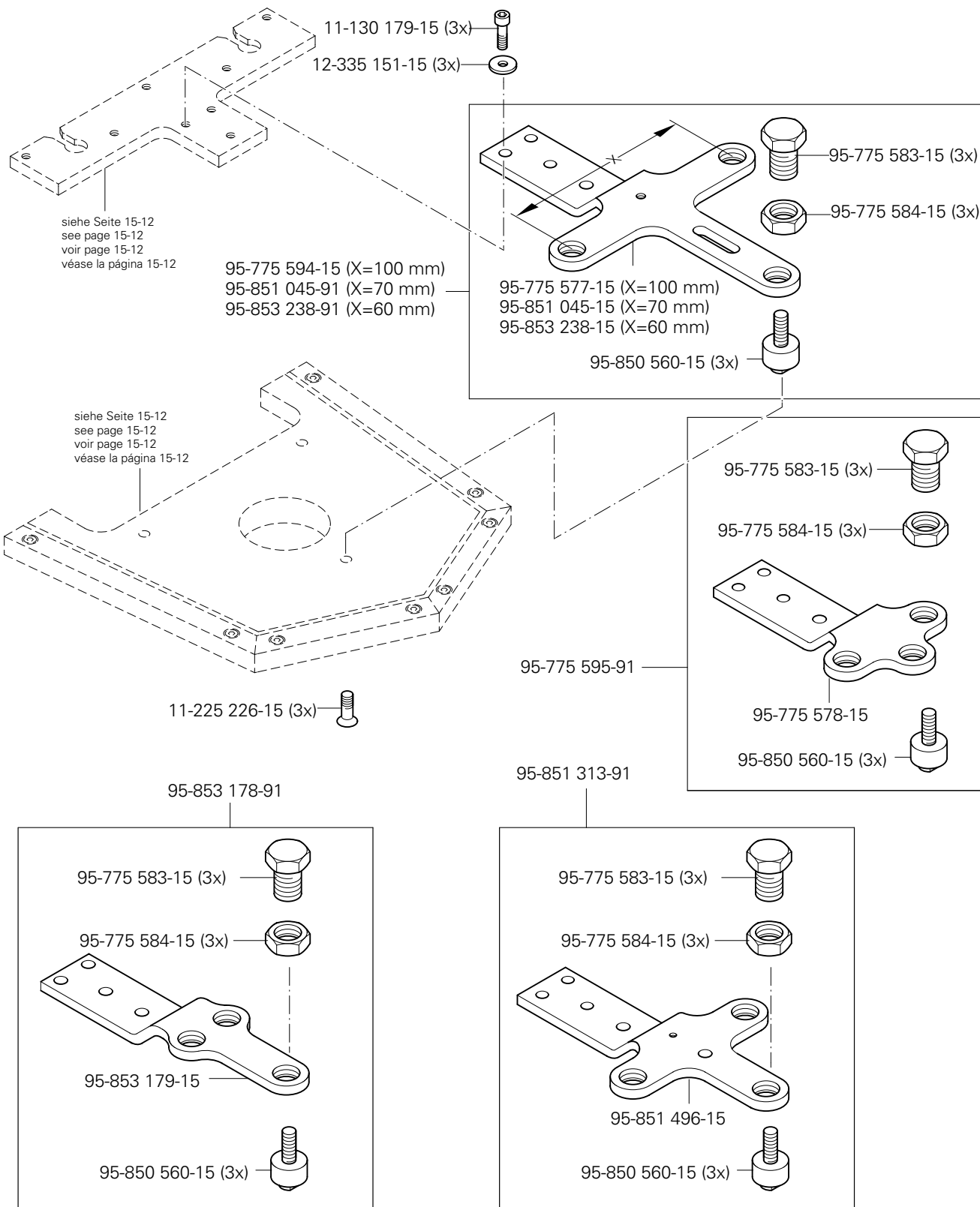
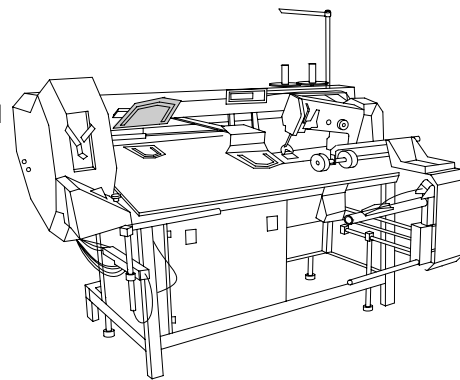

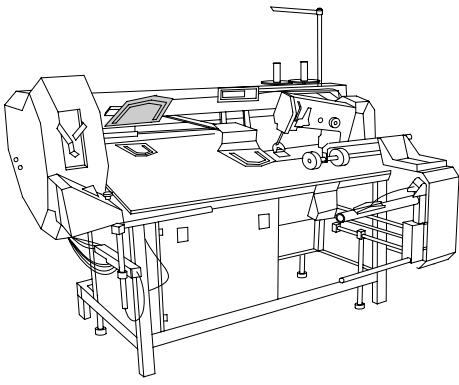

Teilesatz für Etiketten
 Part set for labels
 Jeu de pièces pour les étiquettes
 Juego de piezas para etiquetas

PFAFF 3588-12/021

15.10

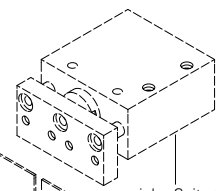
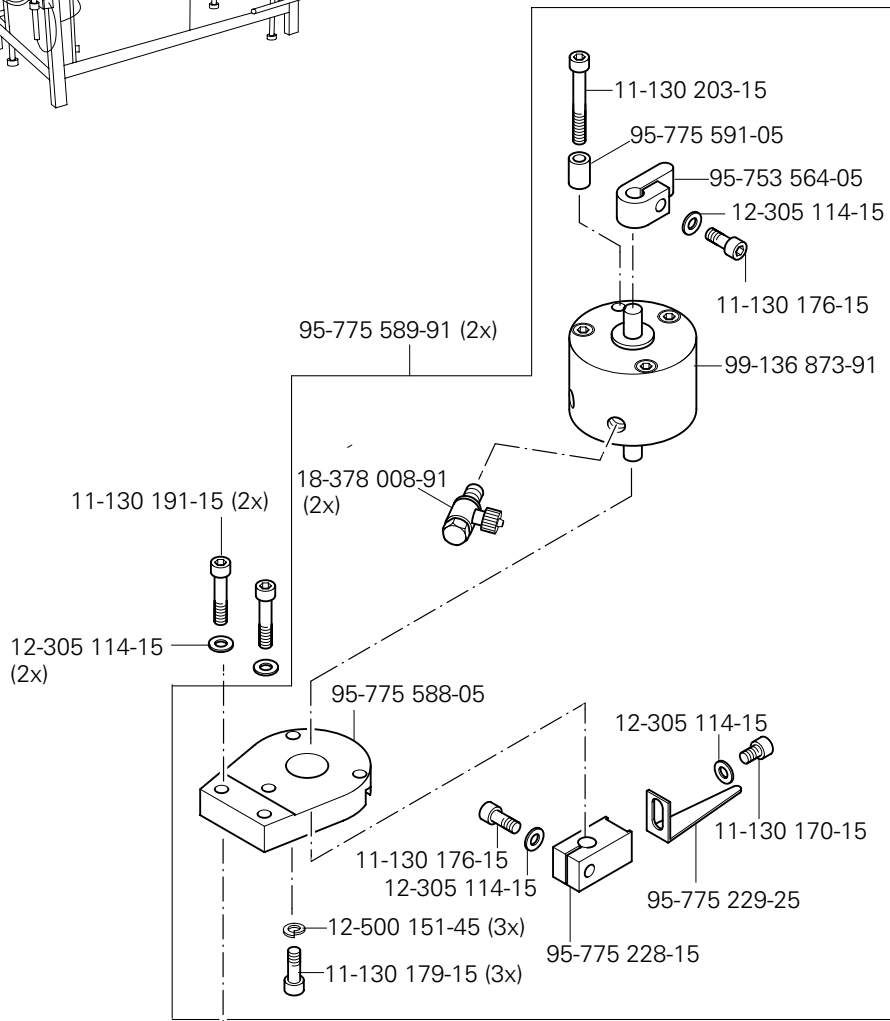

siehe Seite 15-12
 see page 15-12
 voir page 15-12
 véase la página 15-12

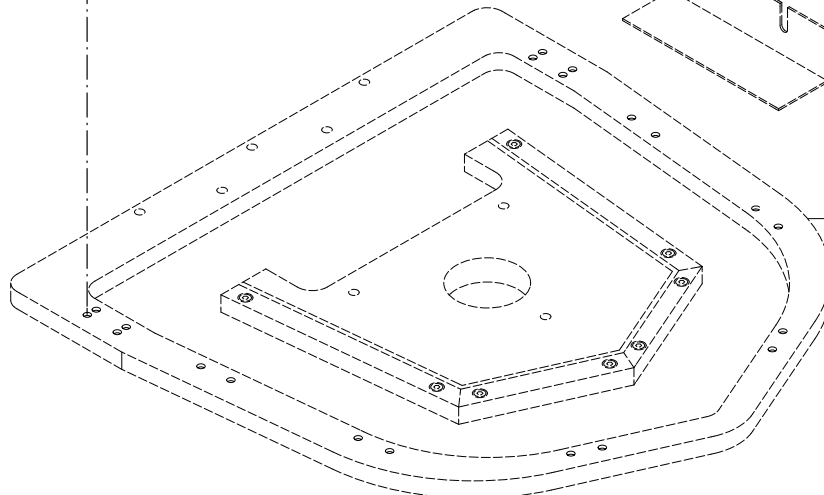

siehe Seite 15-12
 see page 15-12
 voir page 15-12
 véase la página 15-12

15.10

Teilesatz für Etiketten
Part set for labels
Jeu de pièces pour les étiquettes
Juego de piezas para etiquetas

PFAFF 3588-12/021

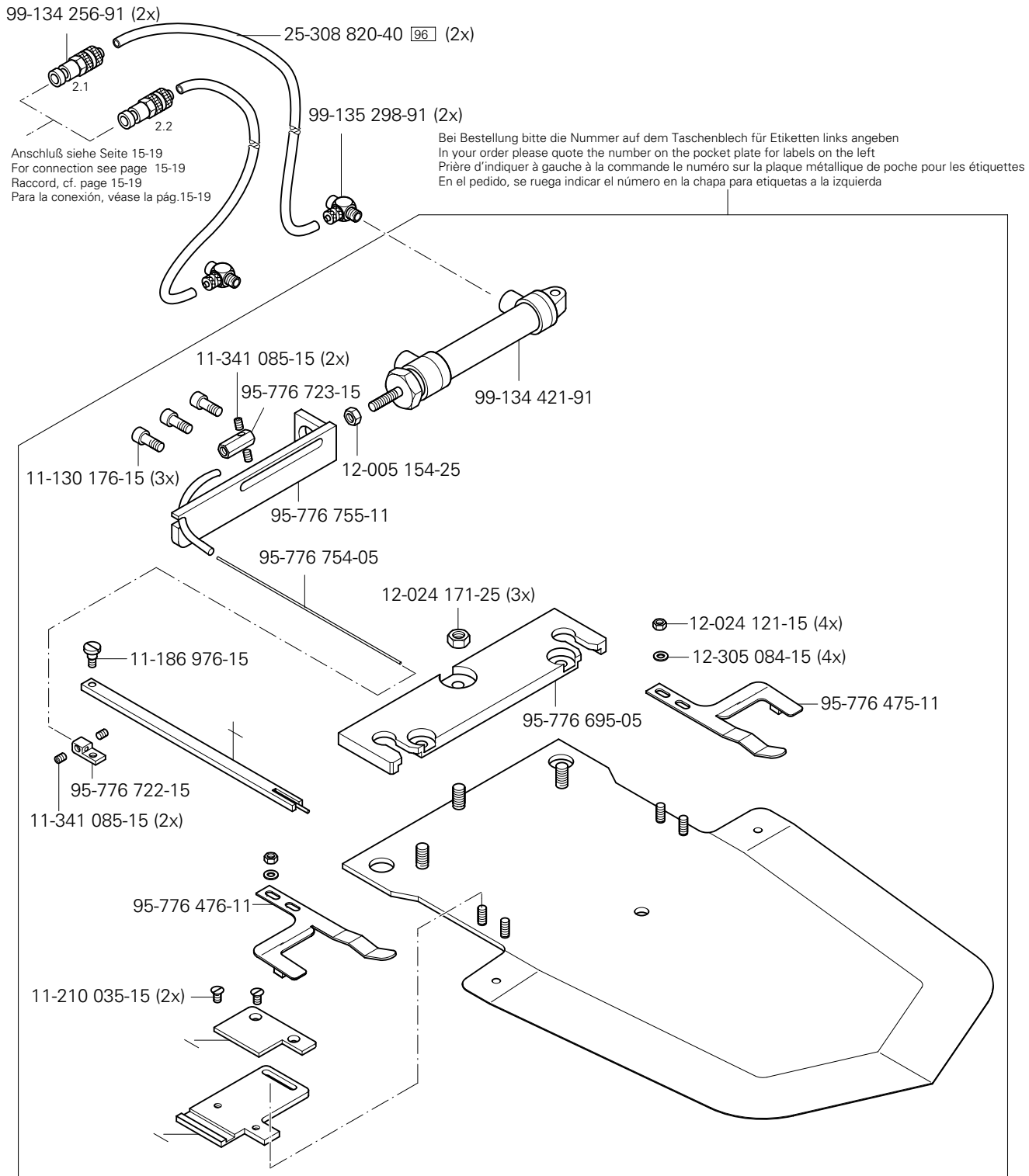
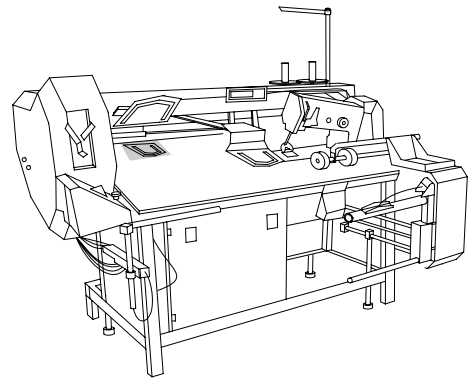

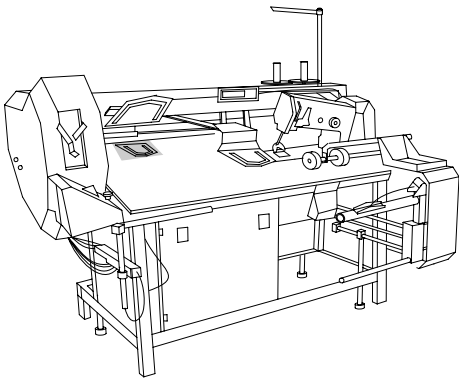

Teilesatz für Etiketten
 Part set for labels
 Jeu de pièces pour les étiquettes
 Juego de piezas para etiquetas

PFAFF 3588-12/021

15.10

99-134 256-91 (2x)

25-308 820-40 96 (2x)



Anschluß siehe Seite 15-19
 For connection see page 15-19
 Raccord, cf. page 15-19
 Para la conexión, véase la pág. 15-19

99-135 298-91 (2x)

Bei Bestellung bitte die Nummer auf dem Taschenblech für Etiketten rechts angeben
 In your order please quote the number on the pocket plate for labels on the right
 Prière d'indiquer à droite à la commande le numéro sur la plaque métallique de poche pour les étiquettes
 En el pedido, se ruega indicar el número en la chapa para etiquetas a la derecha

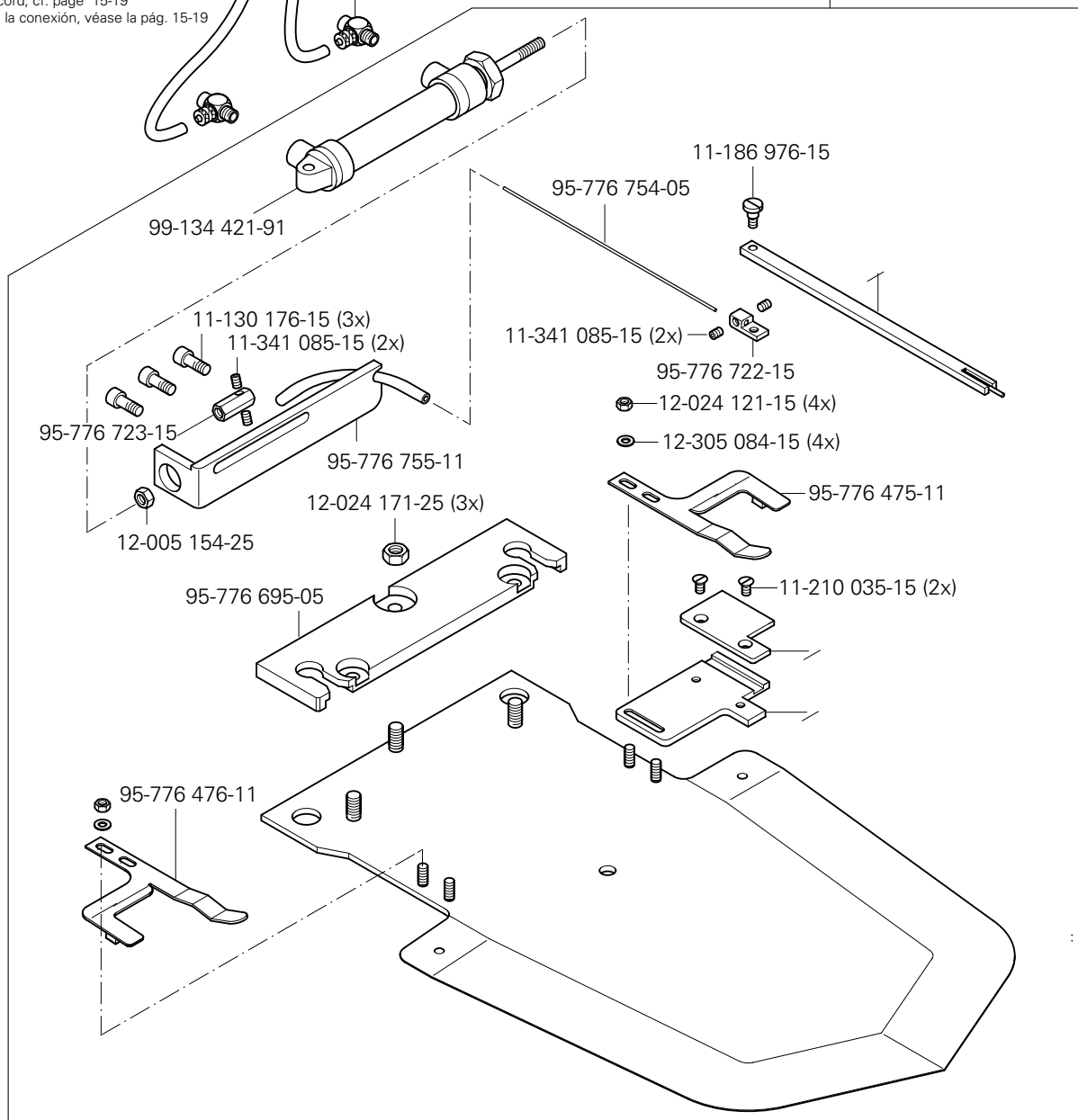

96 siehe Kapitel 2 Erläuterung der Schlüsselzeichen
 see chapter 2 Explanation of key markings
 voir le chap. 2 Explication des symboles
 véase el Cap. 2 Explicaciones de los signos clave

▲ bei Bestellung bitte die Nummer auf dem Taschenblech angeben
 In your order please quote the number on the pocket plate
 Prière d'indiquer à la commande le numéro sur la plaque métallique de poche
 En el pedido, se ruega indicar el número en la chapa de bolsillo

15.10

Teilesatz für Etiketten
 Part set for labels
 Jeu de pièces pour les étiquettes
 Juego de piezas para etiquetas

PFAFF 3588-12/021

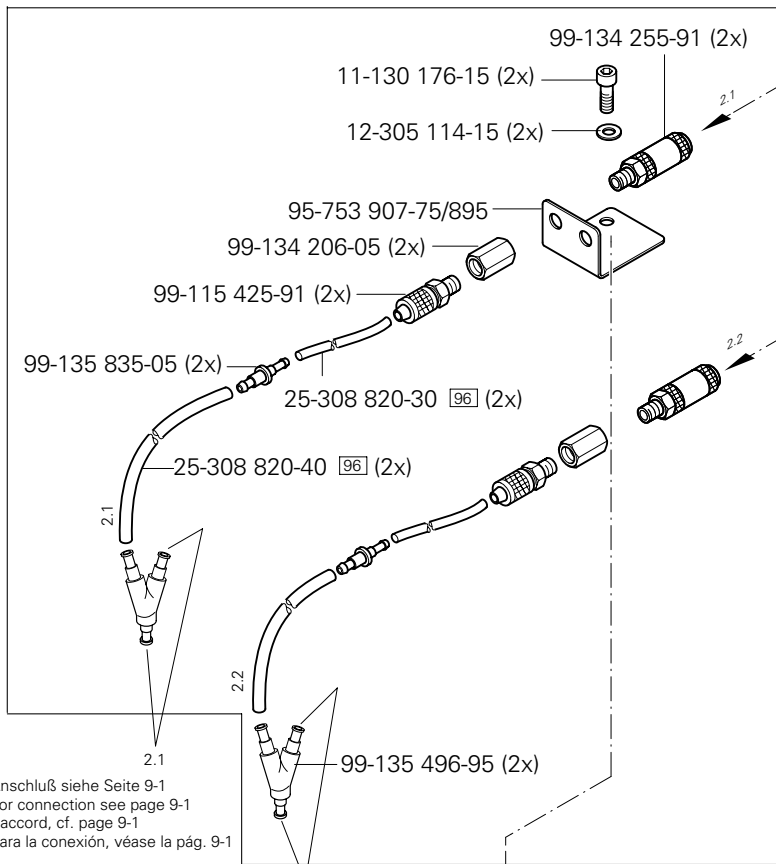
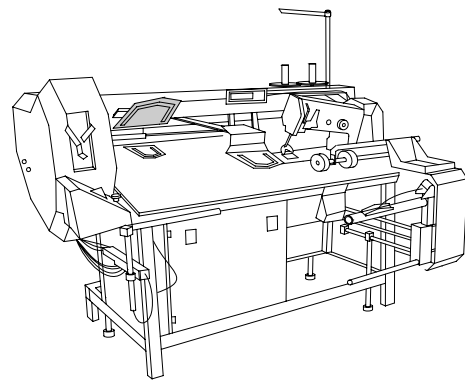

Anschluß siehe Seite 15-17 und 15-18
 For connection see page 15-17 and 15-18
 Raccord, cf. page 15-17 et 15-18
 Para la conexión, véase la pág. 15-17 y 15-18

2.1
 Anschluß siehe Seite 9-1
 For connection see page 9-1
 Raccord, cf. page 9-1
 Para la conexión, véase la pág. 9-1

2.2
 Anschluß siehe Seite 9-1
 For connection see page 9-1
 Raccord, cf. page 9-1
 Para la conexión, véase la pág. 9-1

95-776 566-90

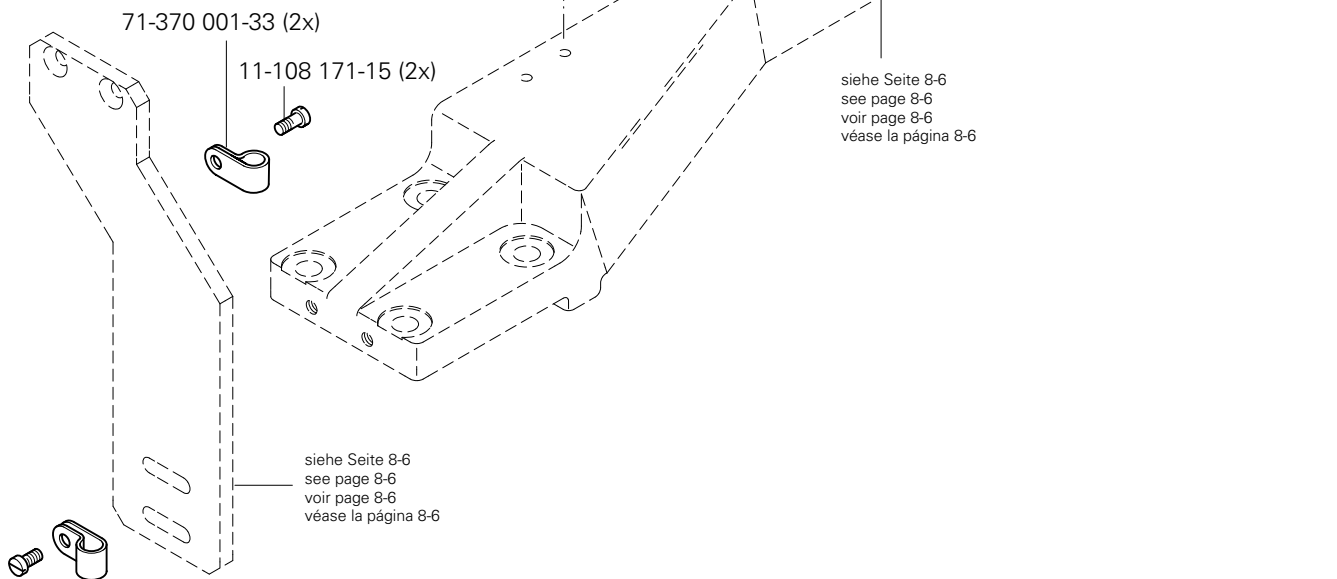

siehe Seite 8-6
 see page 8-6
 voir page 8-6
 véase la página 8-6

siehe Seite 8-6
 see page 8-6
 voir page 8-6
 véase la página 8-6

Teilesatz für Multisize
 Multi-size part set
 Jeu de pièces pour multi-taille
 Juego de piezas para tallas múltiples PFA FF 3588-12/021

15.11

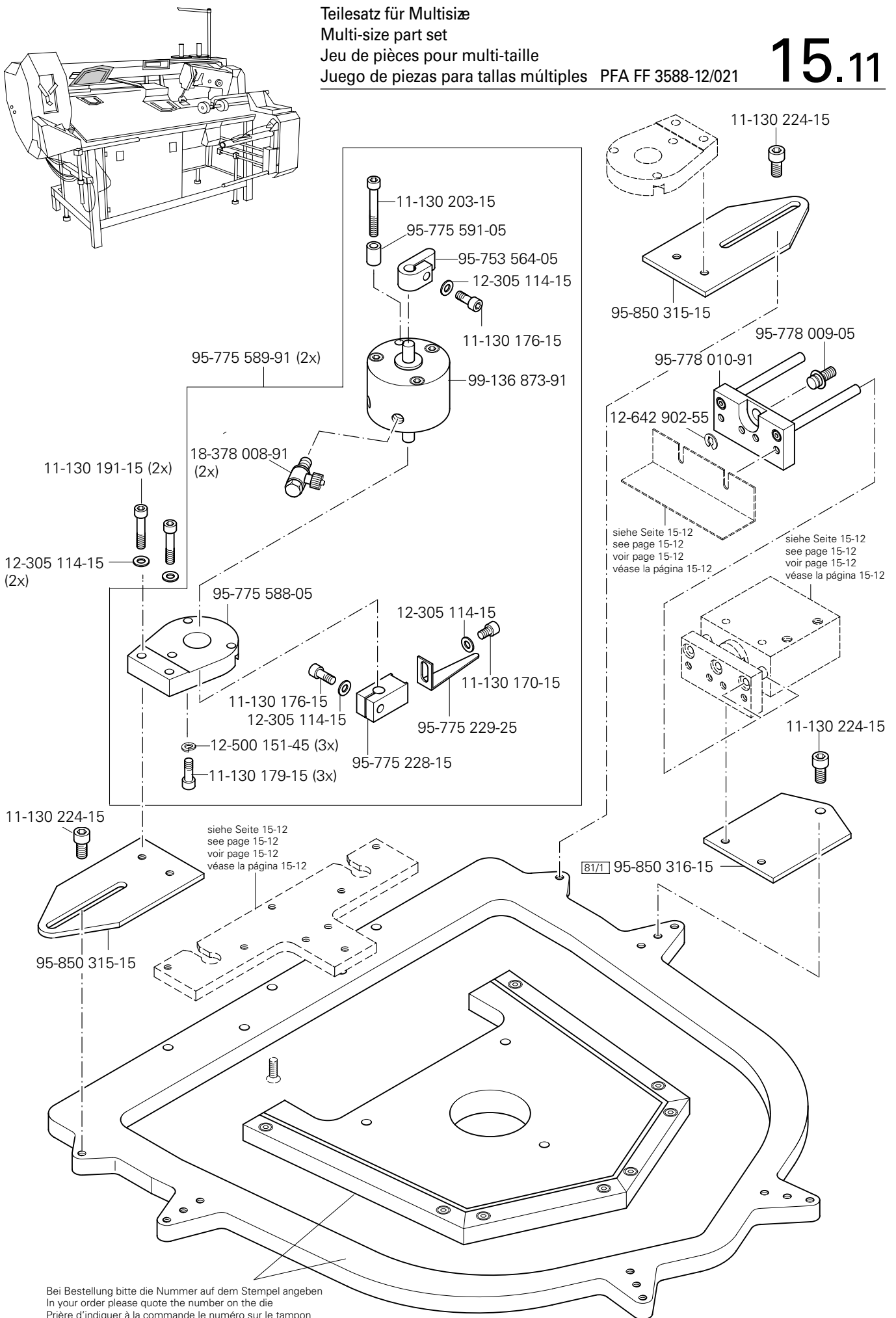

Bei Bestellung bitte die Nummer auf dem Stempel angeben
 In your order please quote the number on the die
 Prière d'indiquer à la commande le numéro sur le tampon
 En el pedido, se ruega indicar el número en el sello.

☐ siehe Kapitel 2 Erläuterung der Schlüsselzeichen
 see chapter 2 Explanation of key markings
 voir le chap. 2 Explication des symboles
 véase el Cap. 2 Explicaciones de los signos clave

15.11

Teilesatz für Multisize
 Multi-size part set
 Jeu de pièces pour multi-taille
 Juego de piezas para tallas múltiples PFAFF 3588-12/021

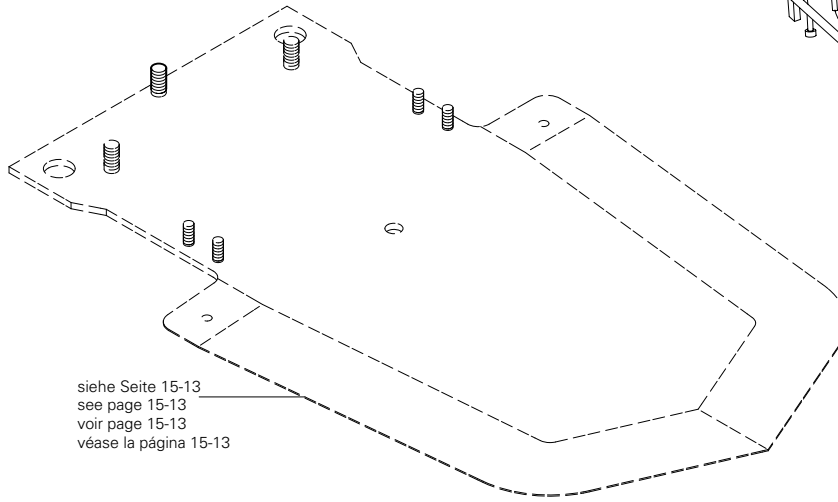
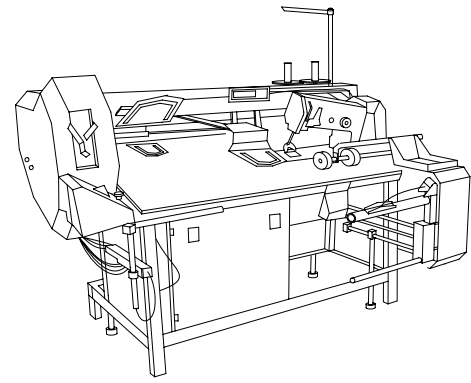

siehe Seite 15-13
 see page 15-13
 voir page 15-13
 véase la página 15-13

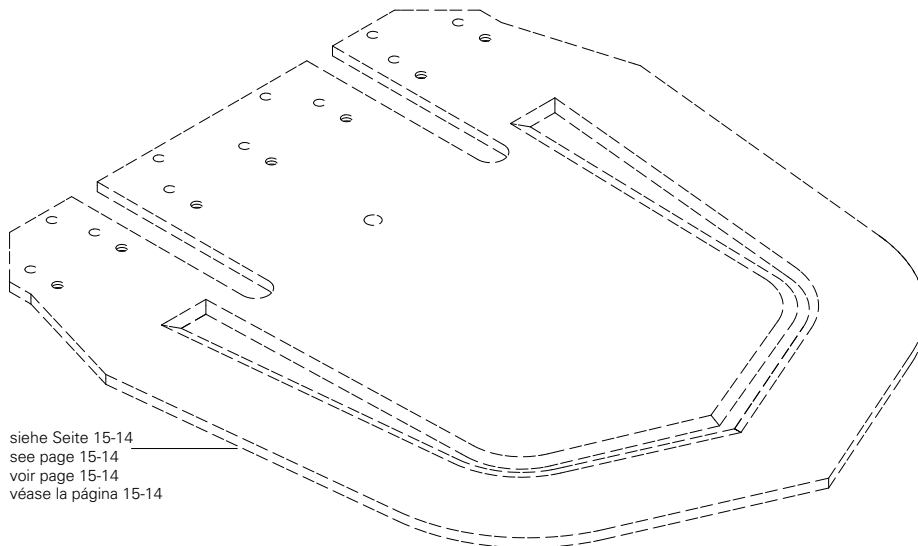

siehe Seite 15-14
 see page 15-14
 voir page 15-14
 véase la página 15-14

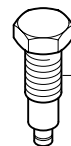

95-852 436-15



95-775 584-15

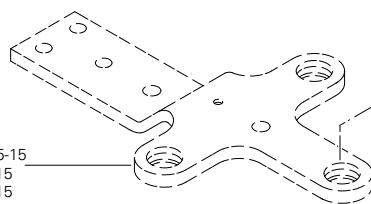

siehe Seite 15-15
 see page 15-15
 voir page 15-15
 véase la página 15-15



95-851 084-15



12-642 901-55

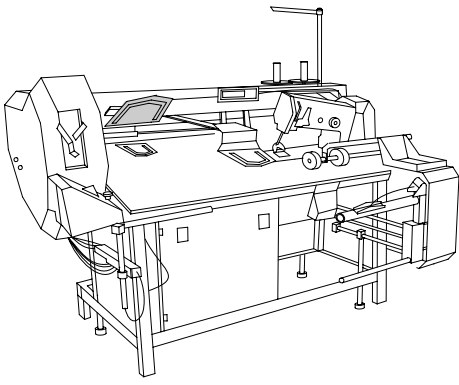

Teilesatz für Patten
 Part set for flaps
 Jeu de pièces pour pattes
 Juego de piezas para solapas de bolsillo

PFAFF 3588-12/021

15.12

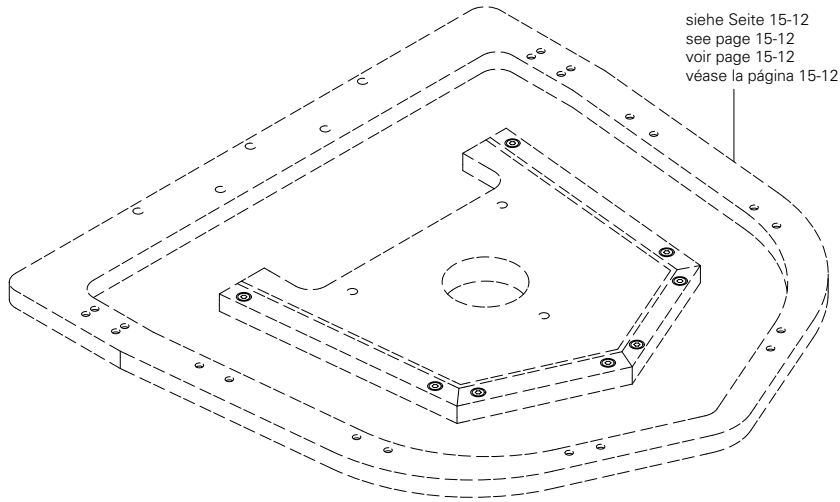

siehe Seite 15-12
 see page 15-12
 voir page 15-12
 véase la página 15-12

Bei Bestellung bitte die Nummer auf dem Taschenblech angeben
 In your order please quote the number on the pocket plate
 Prière d'indiquer à la commande le numéro sur la plaque métallique de poche
 En el pedido, se ruega indicar el número en la chapa de bolsillo.

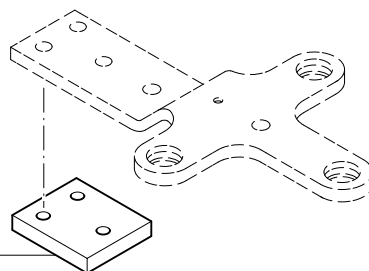
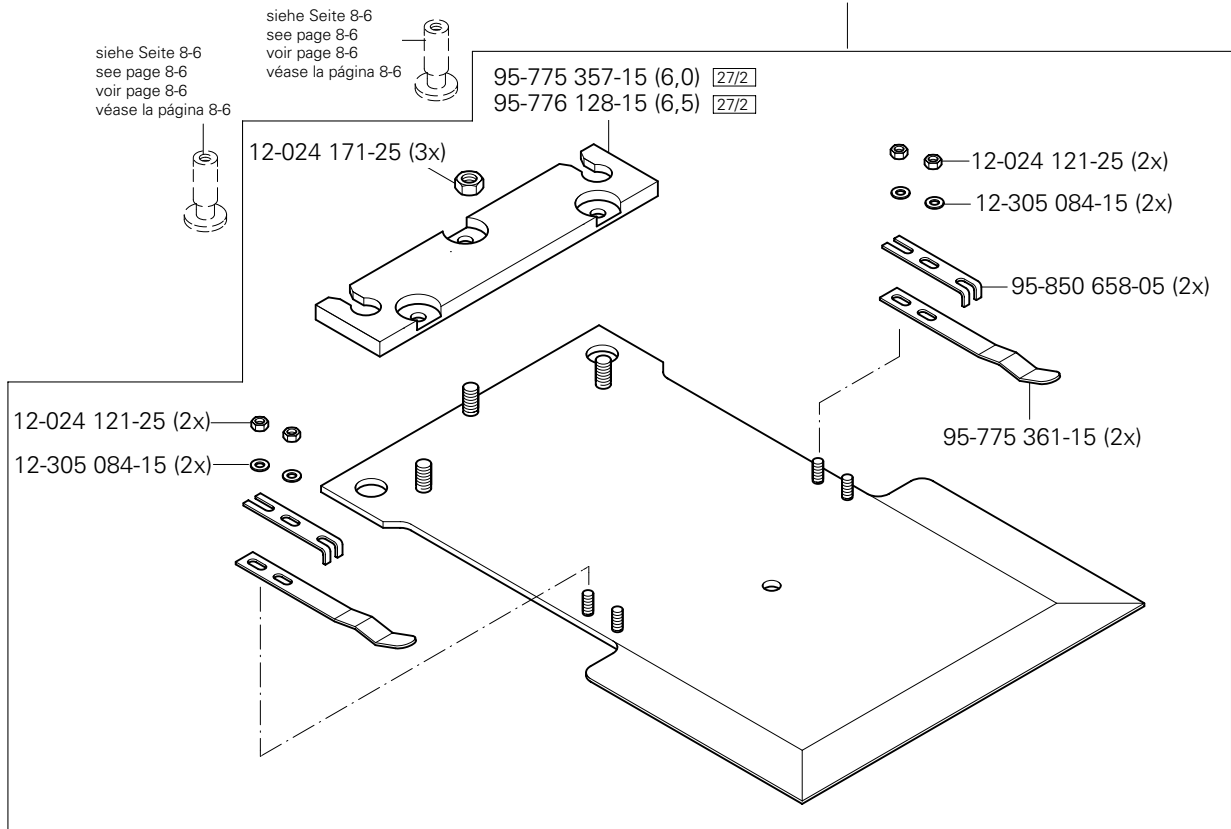

siehe Seite 15-15
 see page 15-15
 voir page 15-15
 véase la página 15-15

95-776 429-05

15.12

Teilesatz für Patten
 Part set for flaps
 Jeu de pièces pour pattes
 Juego de piezas para solapas de bolsillo PFAFF 3588-12/021

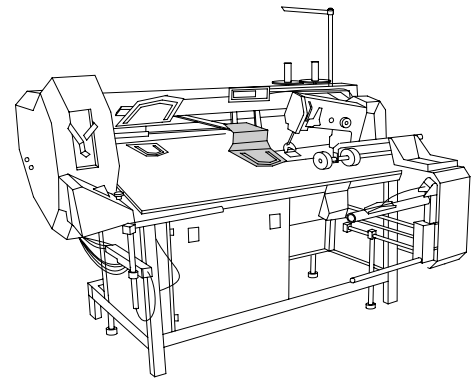

Anschluß siehe Seite 15-25
 For connection see page 15-25
 Raccord, cf. page 15-25
 Para la conexión, véase la pág.15-25

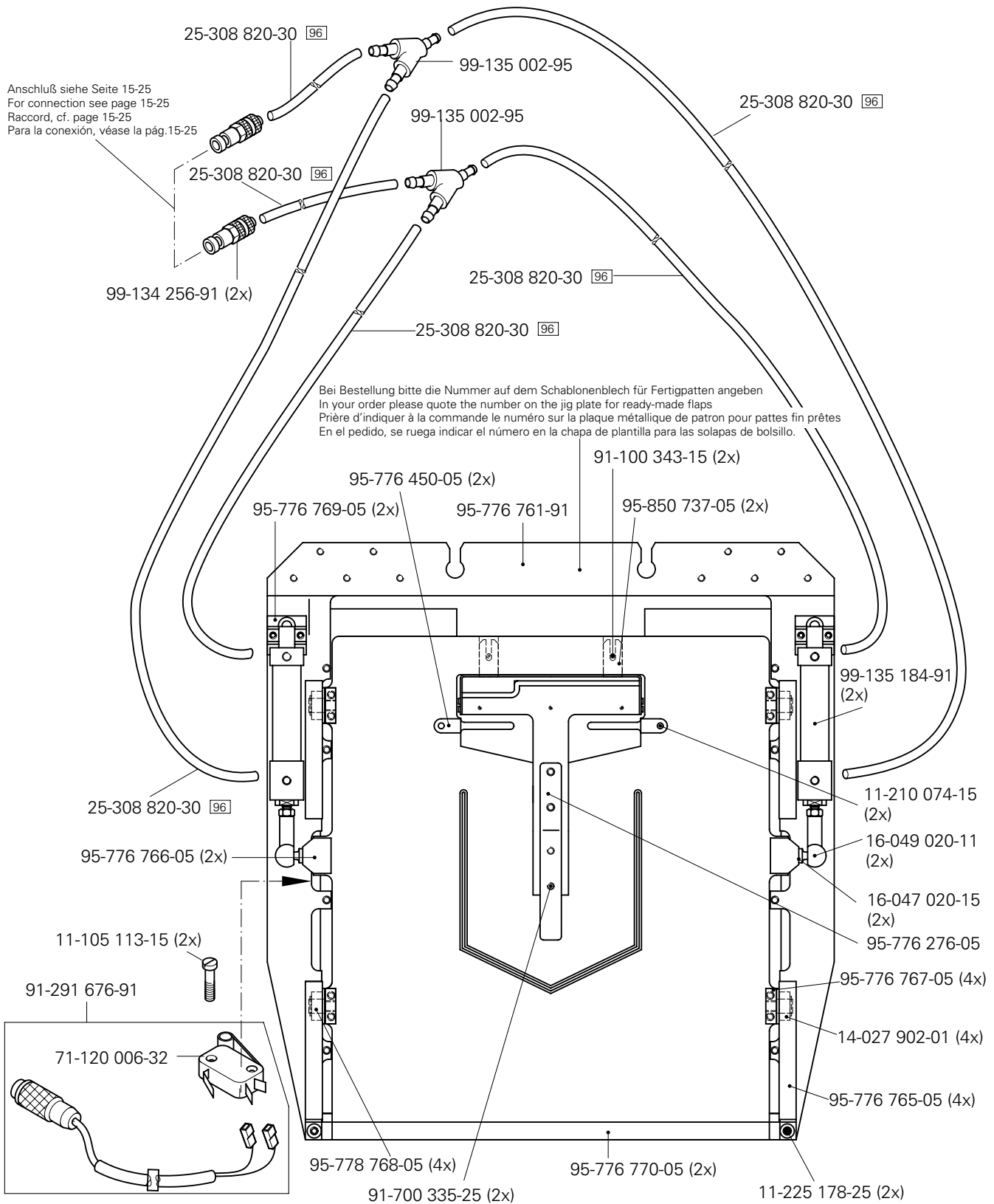

Teilesatz für Patten

Part set for flaps

Jeu de pièces pour pattes

Juego de piezas para solapas de bolsillo PFAFF 3588-12/021

15.12

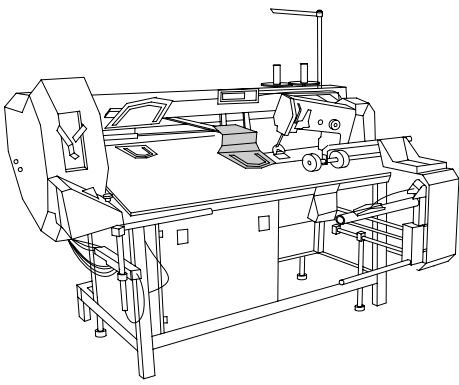

Anschluß siehe Seite 15-25
For connection see page 15-25
Raccord, cf. page 15-25
Para la conexión, véase la pág. 15-25

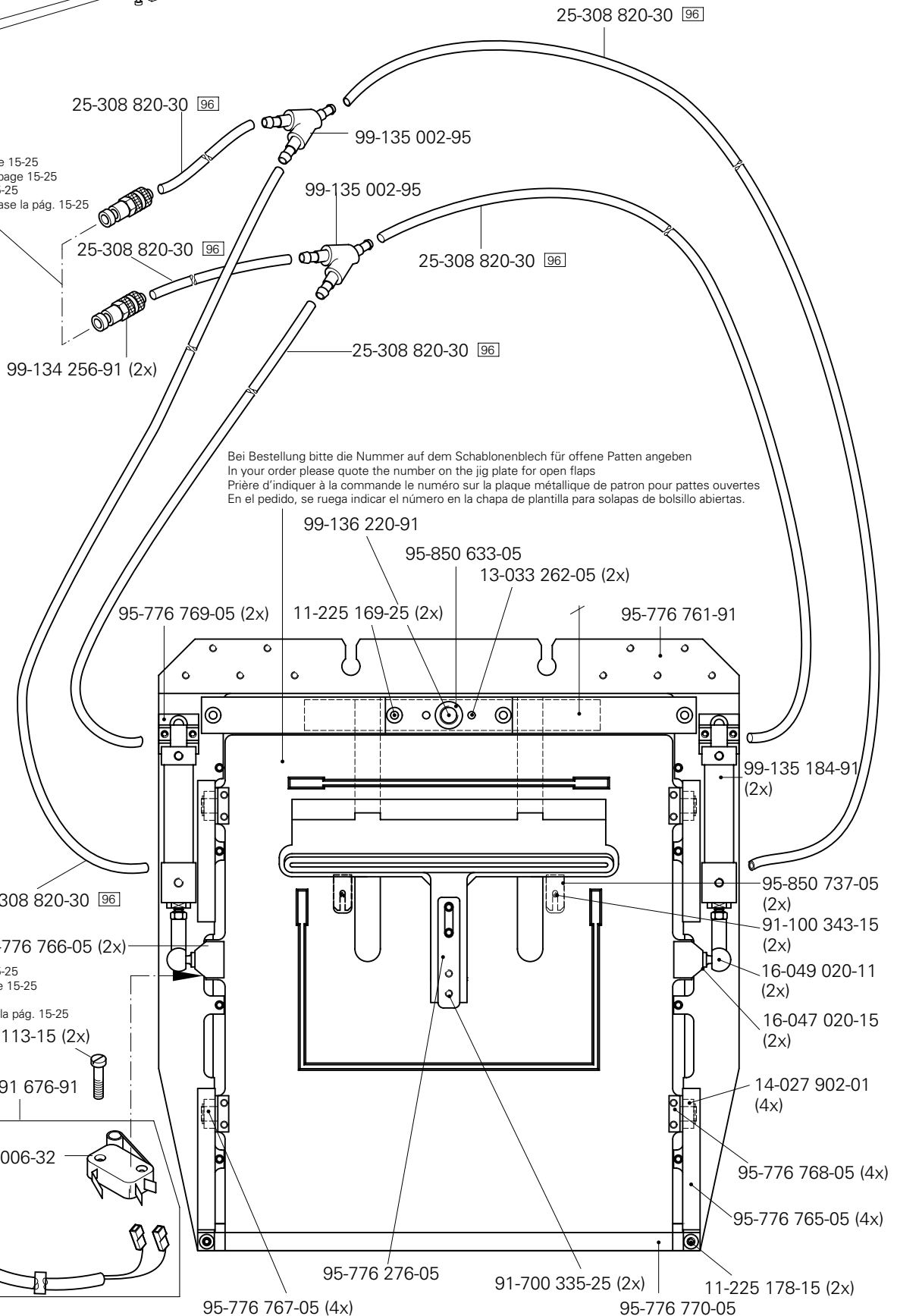

☐ siehe Kapitel 2 Erläuterung der Schlüsselzeichen
see chapter 2 Explanation of key markings
voir le chap. 2 Explication des symboles
véase el Cap. 2 Explicaciones de los signos clave

▲ bei Bestellung bitte die Nummer auf dem Schablonenblech für Stoffrückhalter angeben
In your order please quote the number on the jig plate for cloth retainer
Prière d'indiquer à la commande le numéro sur la plaque métallique de patron pour la retenue de tissu
En el pedido, se ruega indicar el número en la chapa de plantilla para colgador posterior

Teilesatz für Patten
 Part set for flaps
15.12 Jeu de pièces pour pattes
 Juego de piezas para solapas de bolsillo PÄFF 3588-12/021

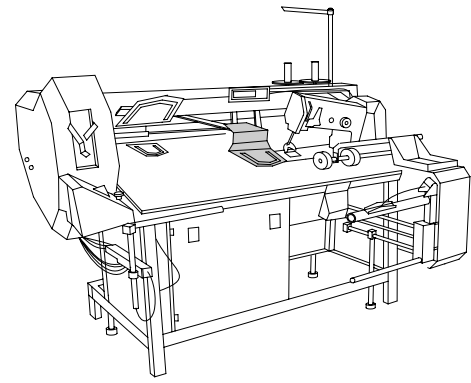

Anschluß siehe Seite 15-24
 For connection see page 15-24
 Raccord, cf. page 15-24
 Para la conexión, véase la pág. 15-24

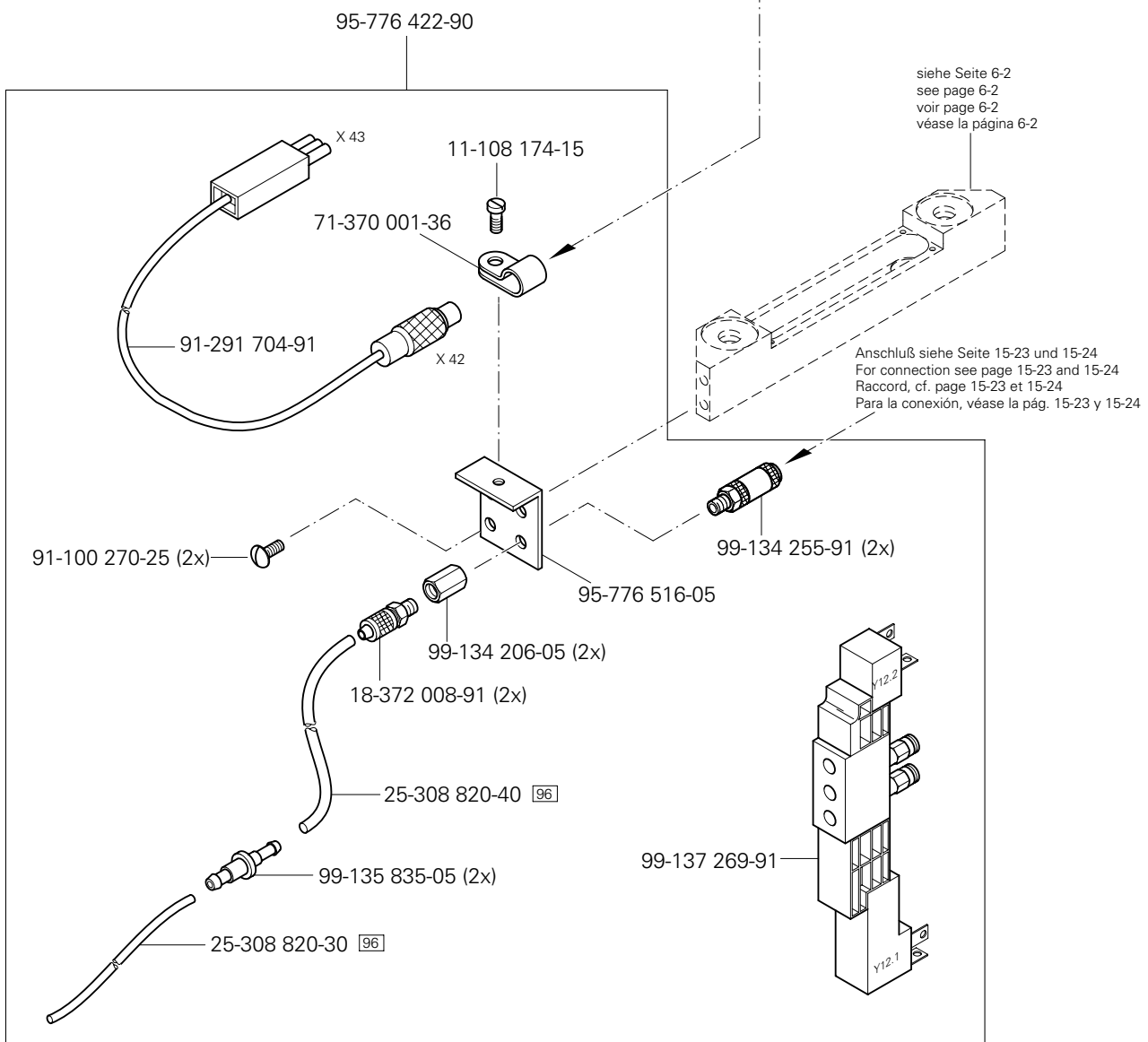

Teilesatz für variablen Nähsschlitz
 Part set for variable sewing slot
 Jeu de pièces pour fente variable de couture
 Juego de piezas para ranura variable de costura PAFF 3588-12/021

15.13

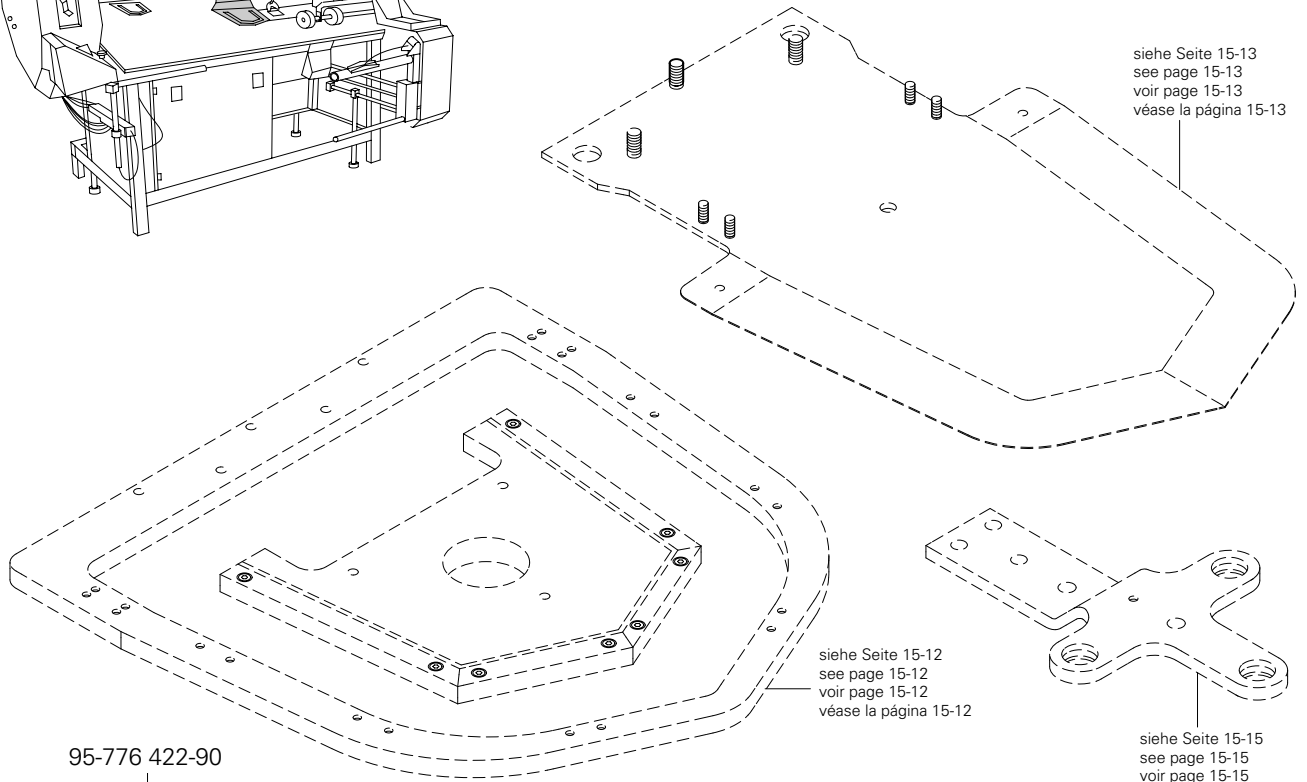
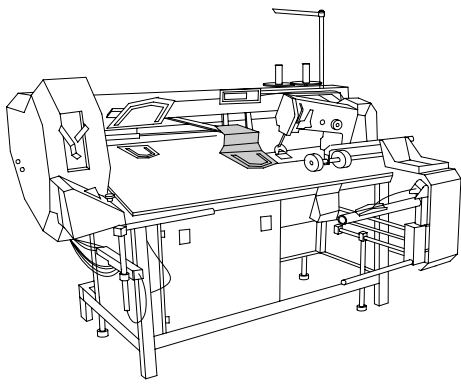

95-776 422-90

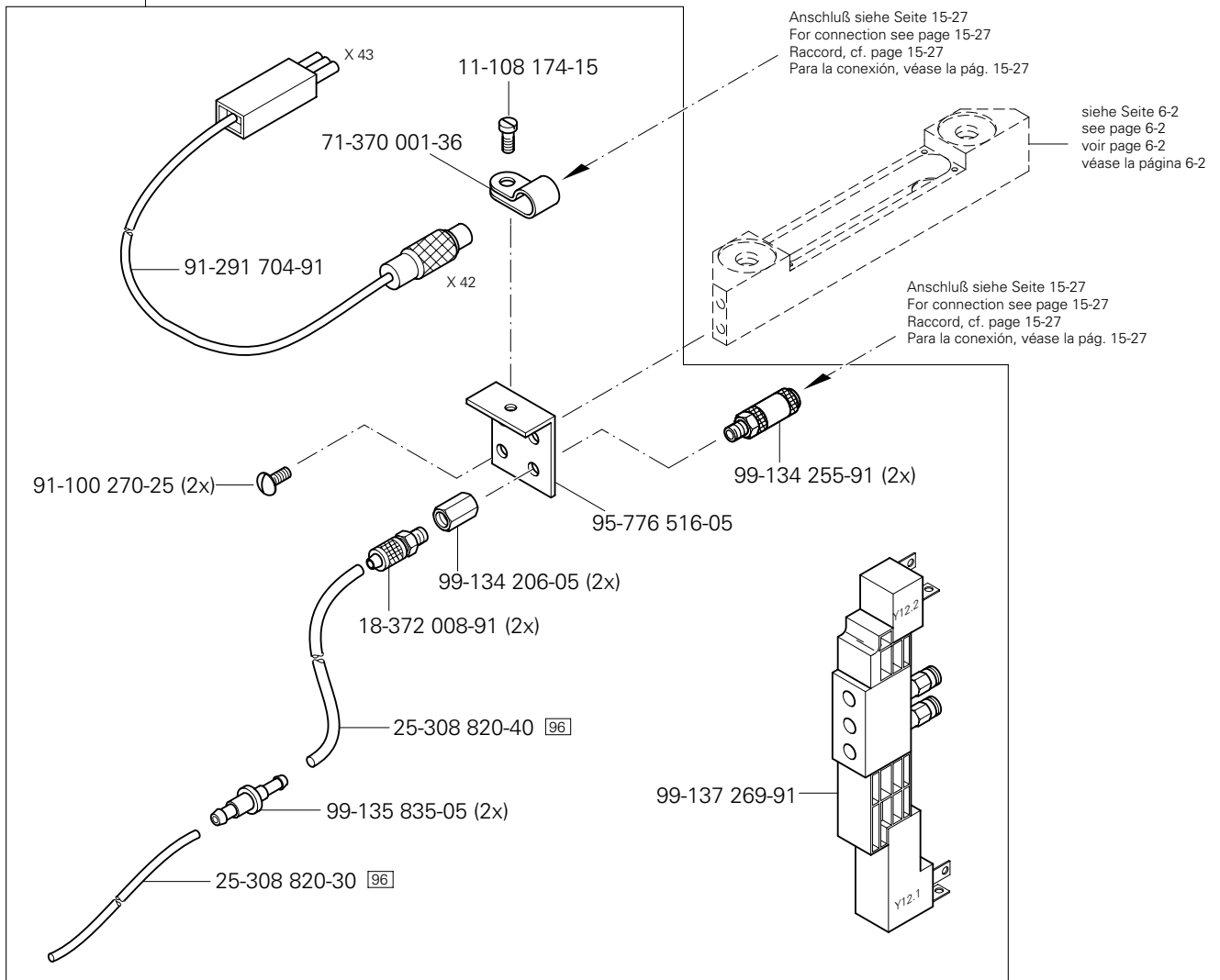

15.13

Teilesatz für variablen Nähslitz
 Part set for variable sewing slot
 Jeu de pièces pour fente variable de couture
 Juego de piezas para ranura variable de costura PFAFF 3588-12/021

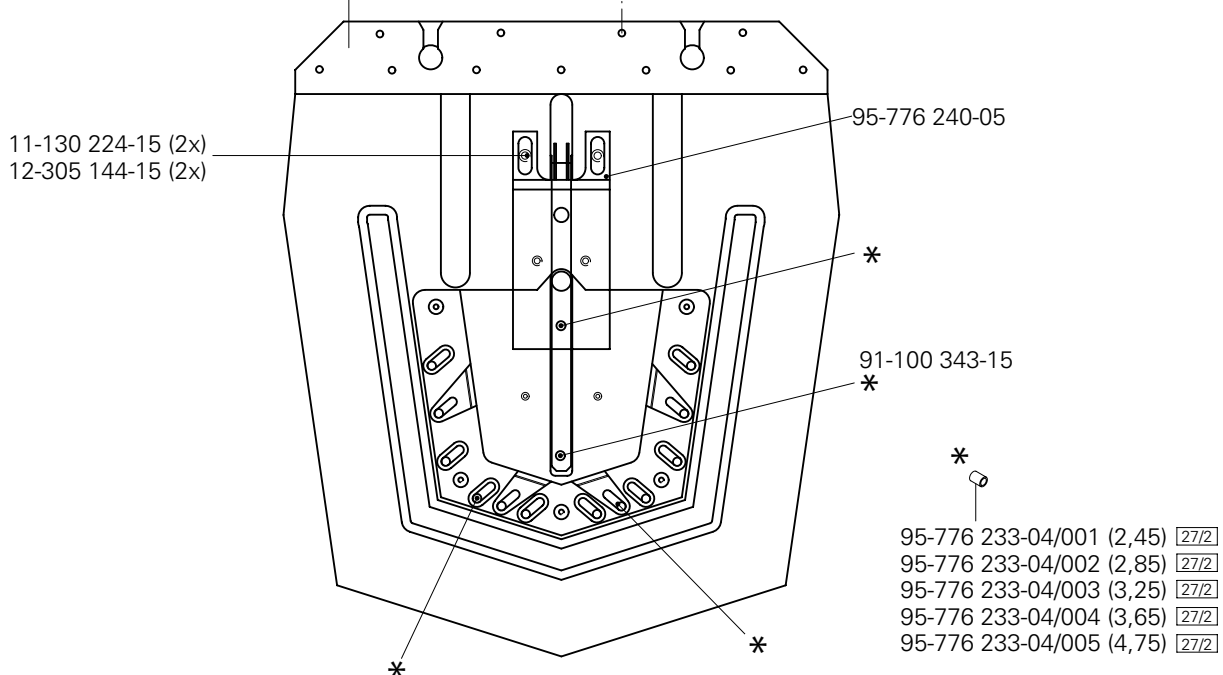
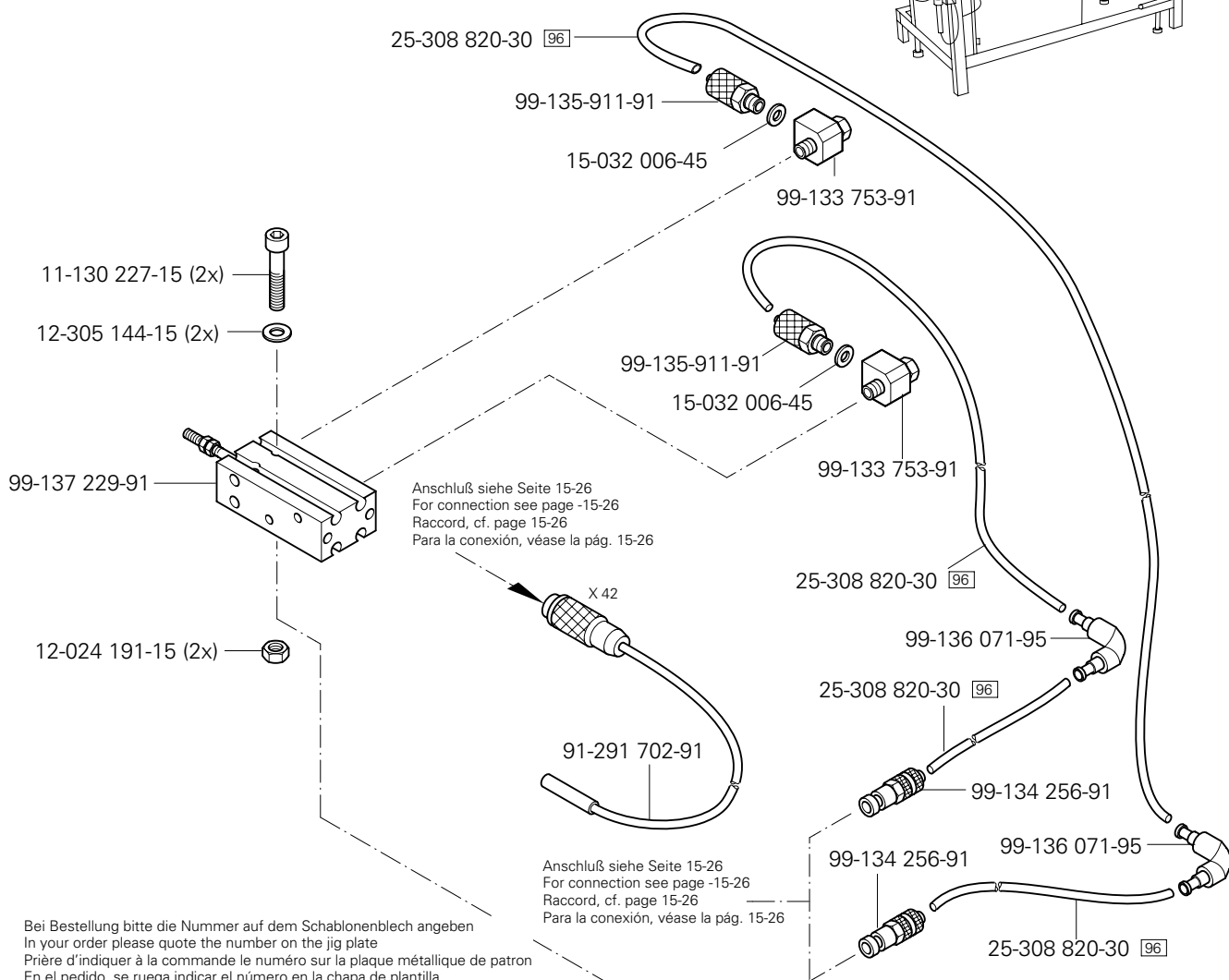
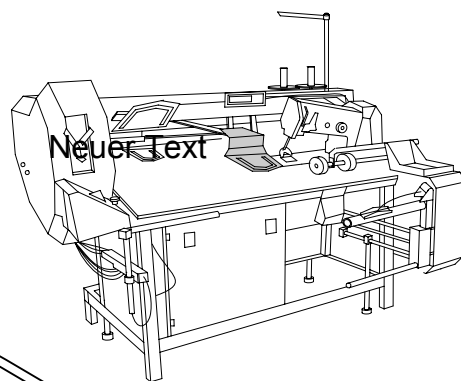

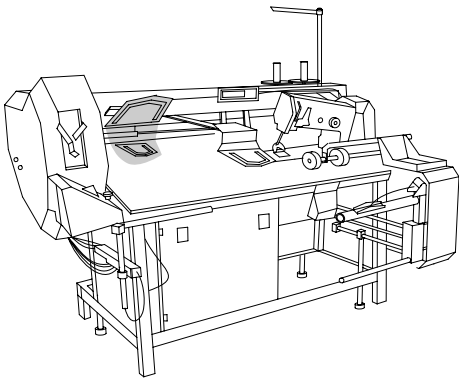



Anbausatz für vorgebuggte Taschen
 Add-on kit for pre-folded packets
 Kit pour poches conformées
 Conjunto de piezas para bolsillo predoblado

PFAFF 3588-12/021

15.14

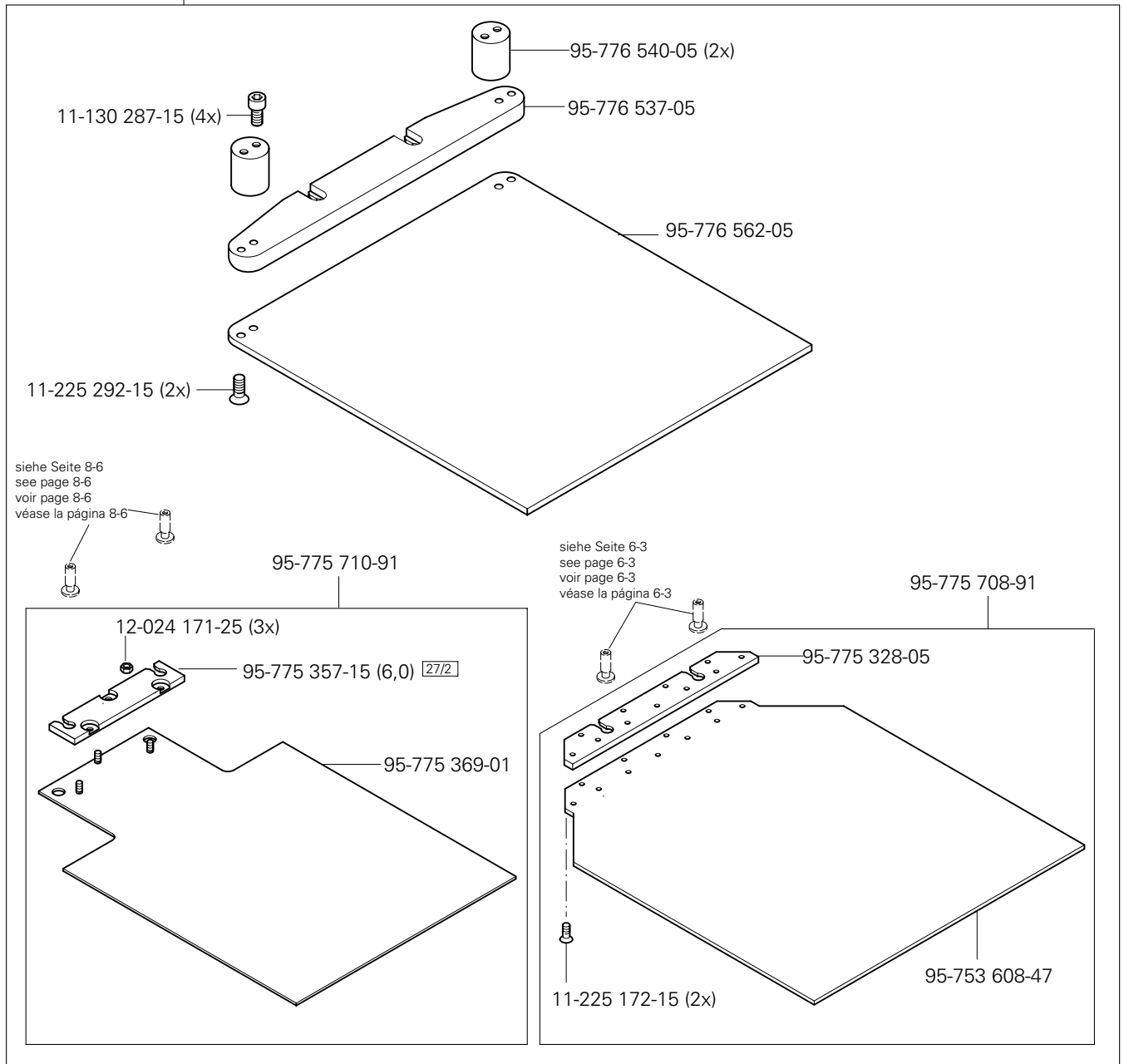
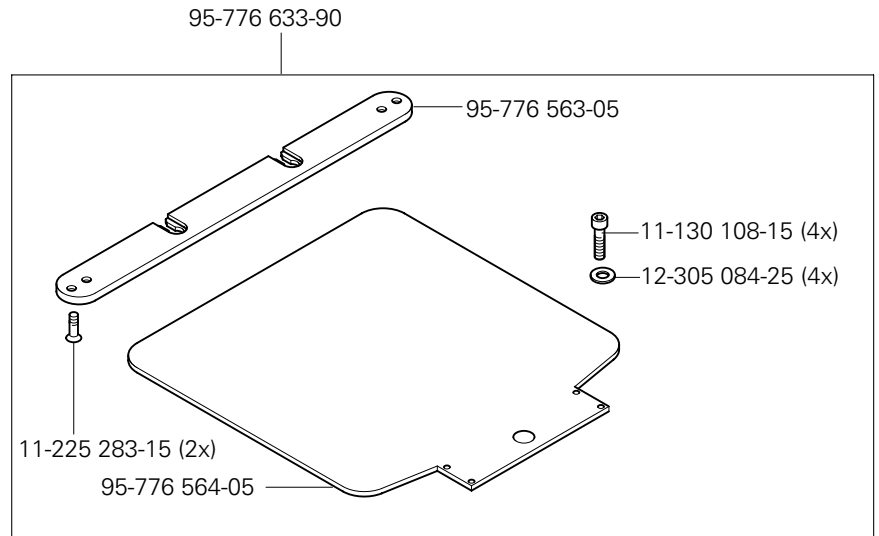
95-776 535-70/895



 siehe Kapitel 2 Erläuterung der Schlüsselzeichen
 see chapter 2 Explanation of key markings
 voir le chap. 2 Explication des symboles
 véase el Cap. 2 Explicaciones de los signos clave

15.15

Teilesatz zum Abschalten der Saugluft

Part set to switch off suction

Jeu de pièces pour arrêter d'aspiration à air

Juego de piezas para deactivar el aire aspirante PFAFF 3588-12/021

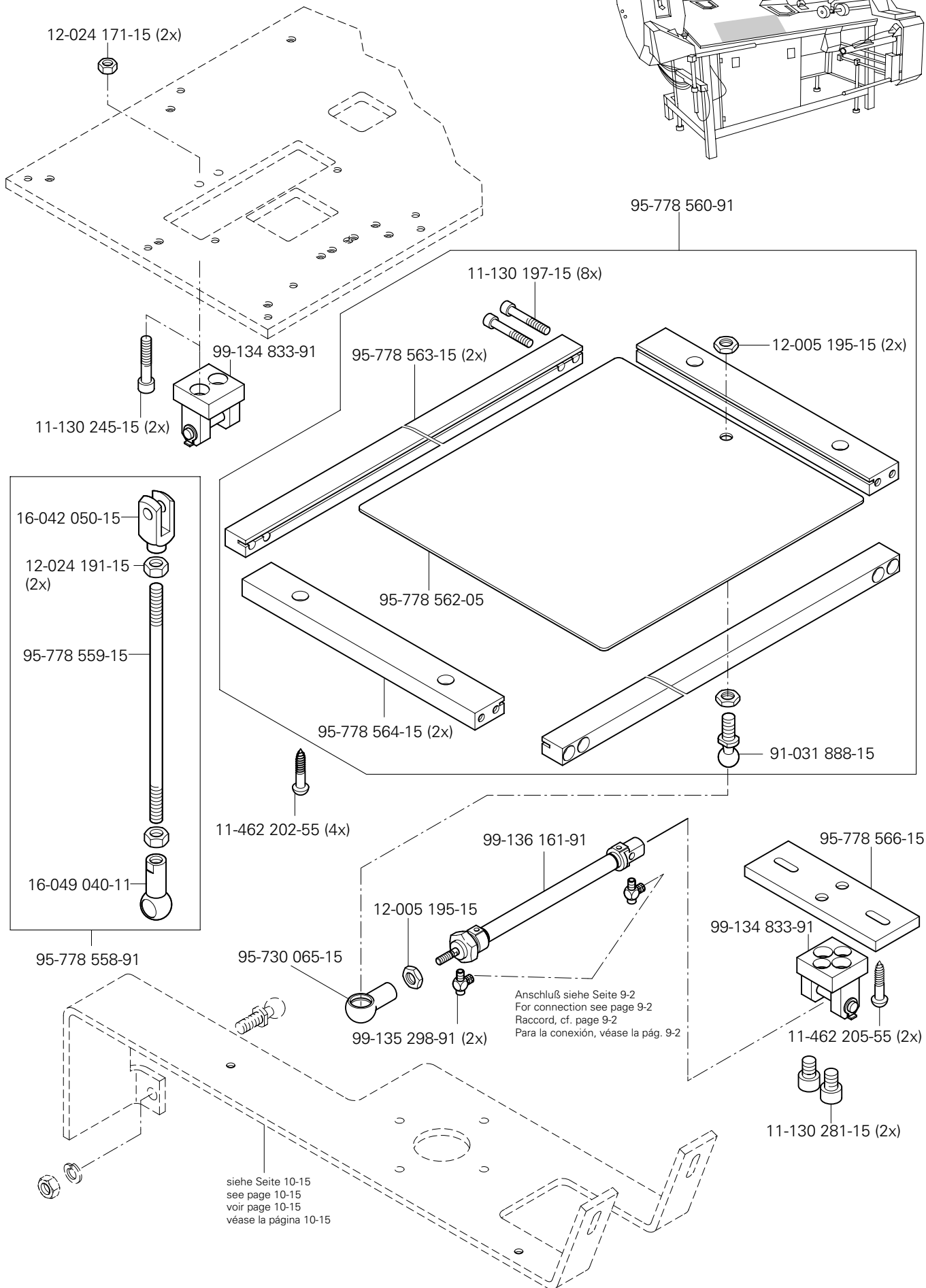
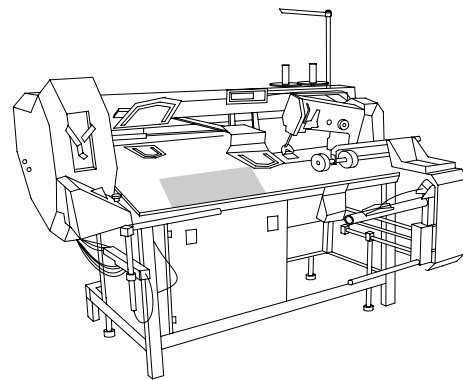

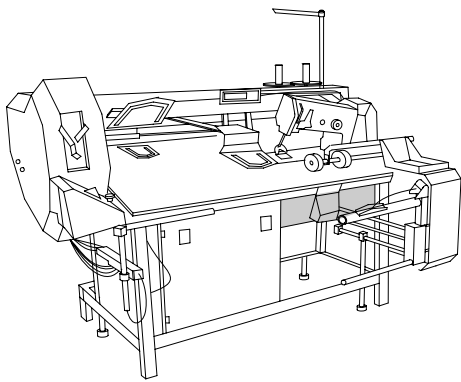

Hubvorrichtung
Lifting mechanism
Mécanisme élévateur
Dispositivo de elevación

PFAFF 3588-12/021

15.16

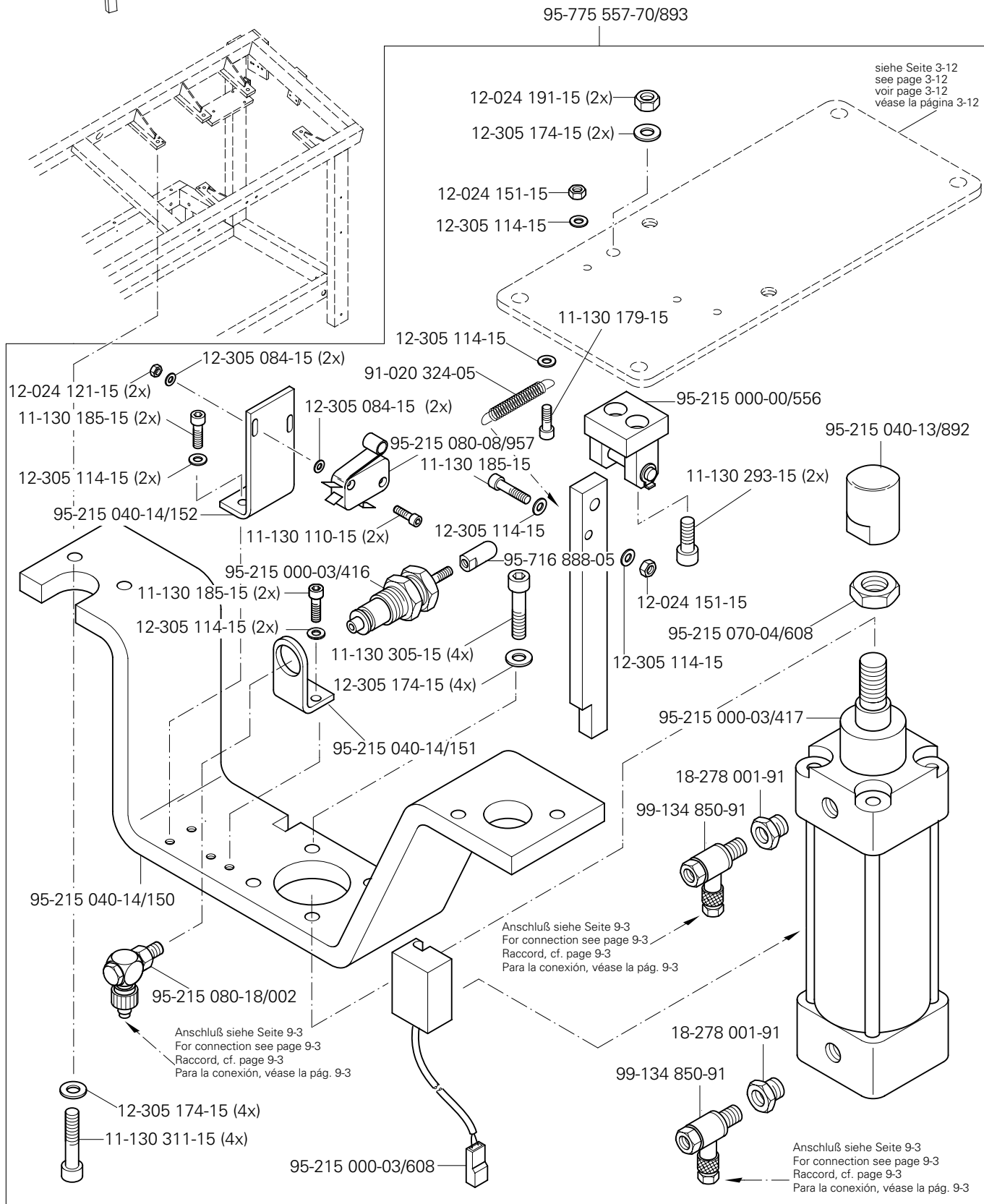

15.17

Adapter für Teilesätze der PFAFF 3568
 Gauge parts adapter for the PFAFF 3568
 Adapteur de kits pour la PFAFF 3568
 Adaptador para juegos de piezas de la PFAFF 3568

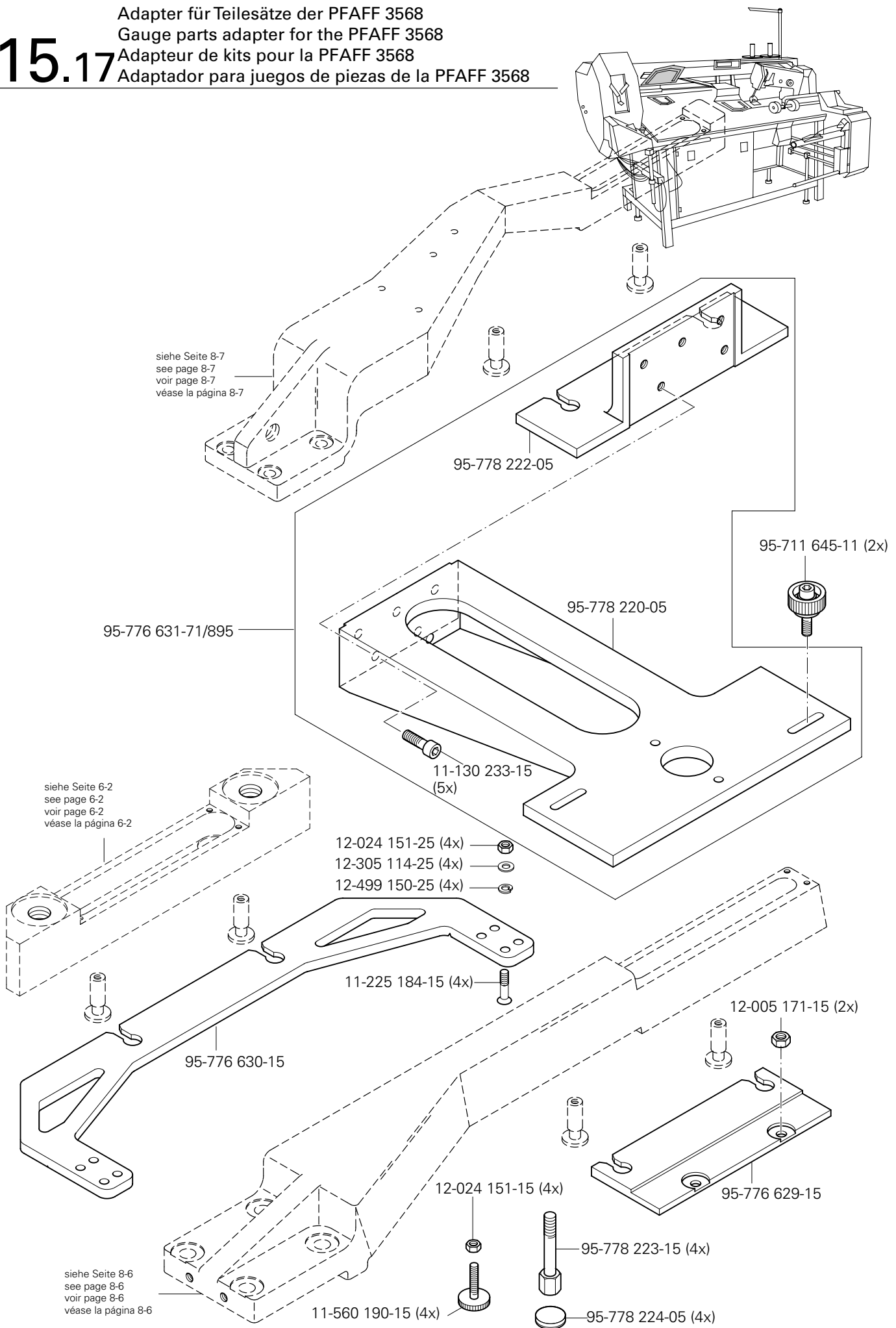

siehe Seite 8-7
 see page 8-7
 voir page 8-7
 véase la página 8-7

siehe Seite 6-2
 see page 6-2
 voir page 6-2
 véase la página 6-2

siehe Seite 8-6
 see page 8-6
 voir page 8-6
 véase la página 8-6

- 12-024 151-25 (4x)
- 12-305 114-25 (4x)
- 12-499 150-25 (4x)

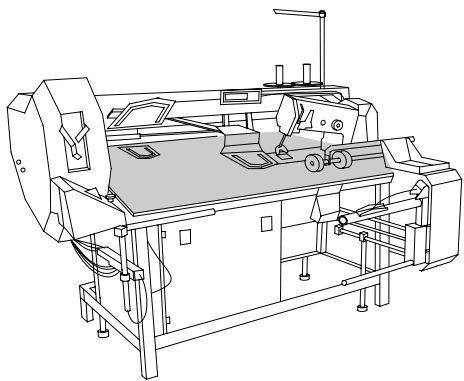

Abweichende Teile der PFAFF 3588-22/021
 Different parts for PFAFF 3588-22/021
 Pièces divergentes de la PFAFF 3588-22/021
 Piezas de la PFAFF 3588-22/021 que son diferentes

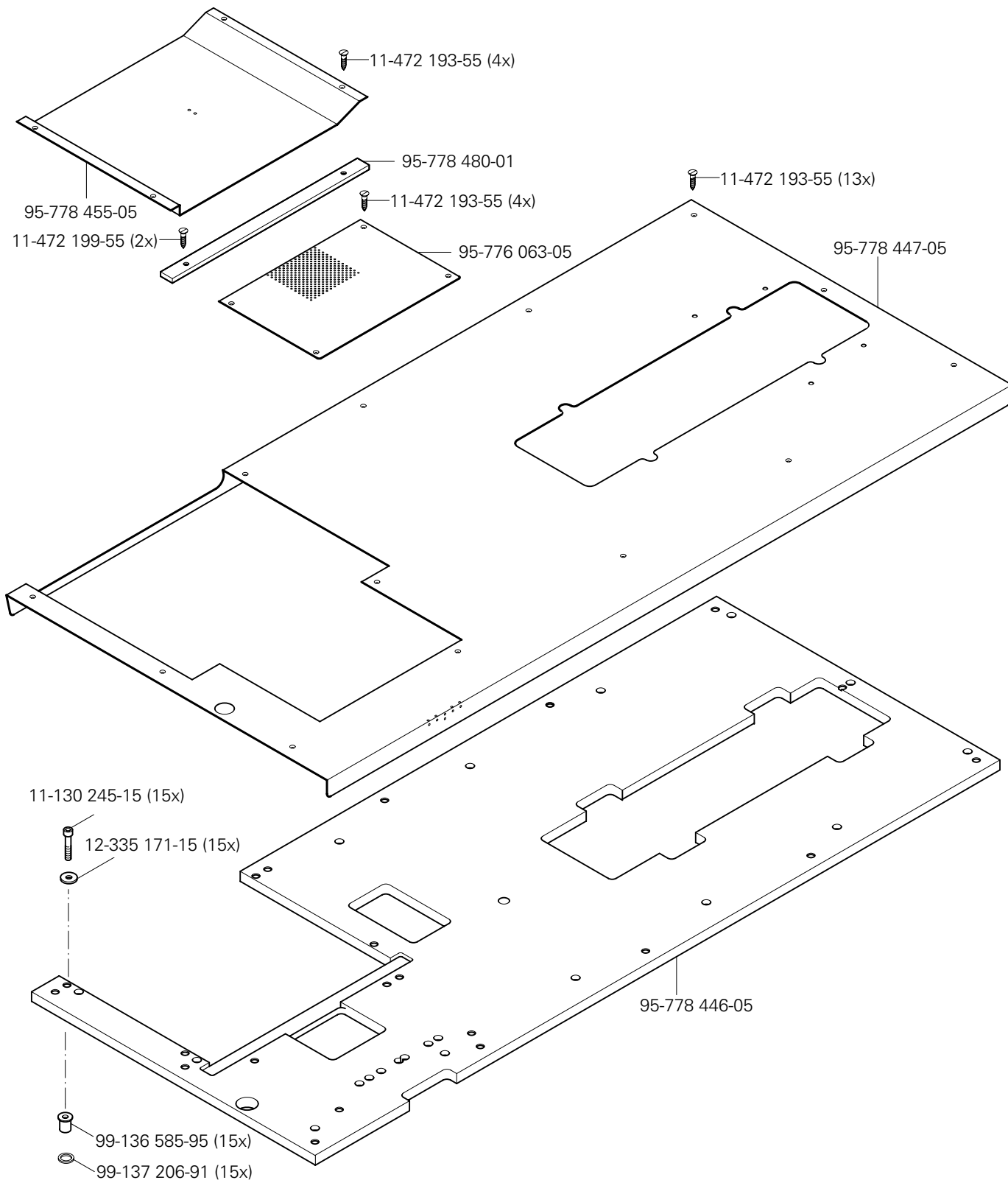



 siehe Kapitel 2 Erläuterung der Schlüsselzeichen
 see chapter 2 Explanation of key markings
 voir le chap. 2 Explication des symboles
 véase el Cap. 2 Explicaciones de los signos clave

(die sonstigen Teile wie in Register 4)
 (for all other parts see Section 4)
 (les autres pièces comme dans les registres 4)
 (las demás piezas como en los registros 4)

16

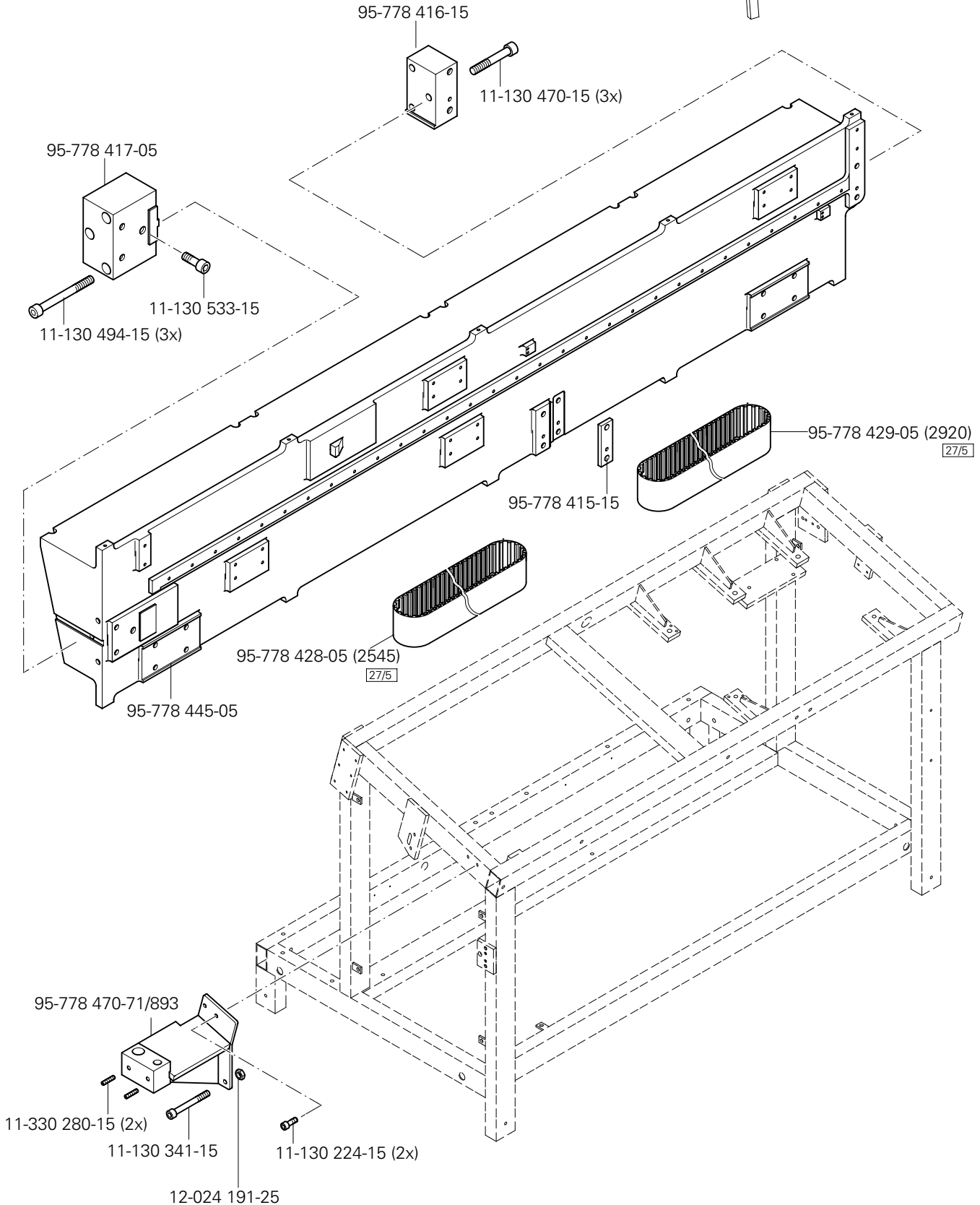
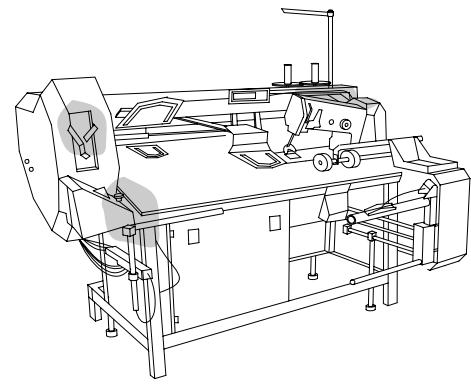
Abweichende Teile der PFAFF 3588-22/021
 Different parts for PFAFF 3588-22/021
 Pièces divergentes de la PFAFF 3588-22/021
 Piezas de la PFAFF 3588-22/021 que son diferentes



Abweichende Teile der PFAFF 3588-22/021
 Different parts for PFAFF 3588-22/021
 Pièces divergentes de la PFAFF 3588-22/021
 Piezas de la PFAFF 3588-22/021 que son diferentes

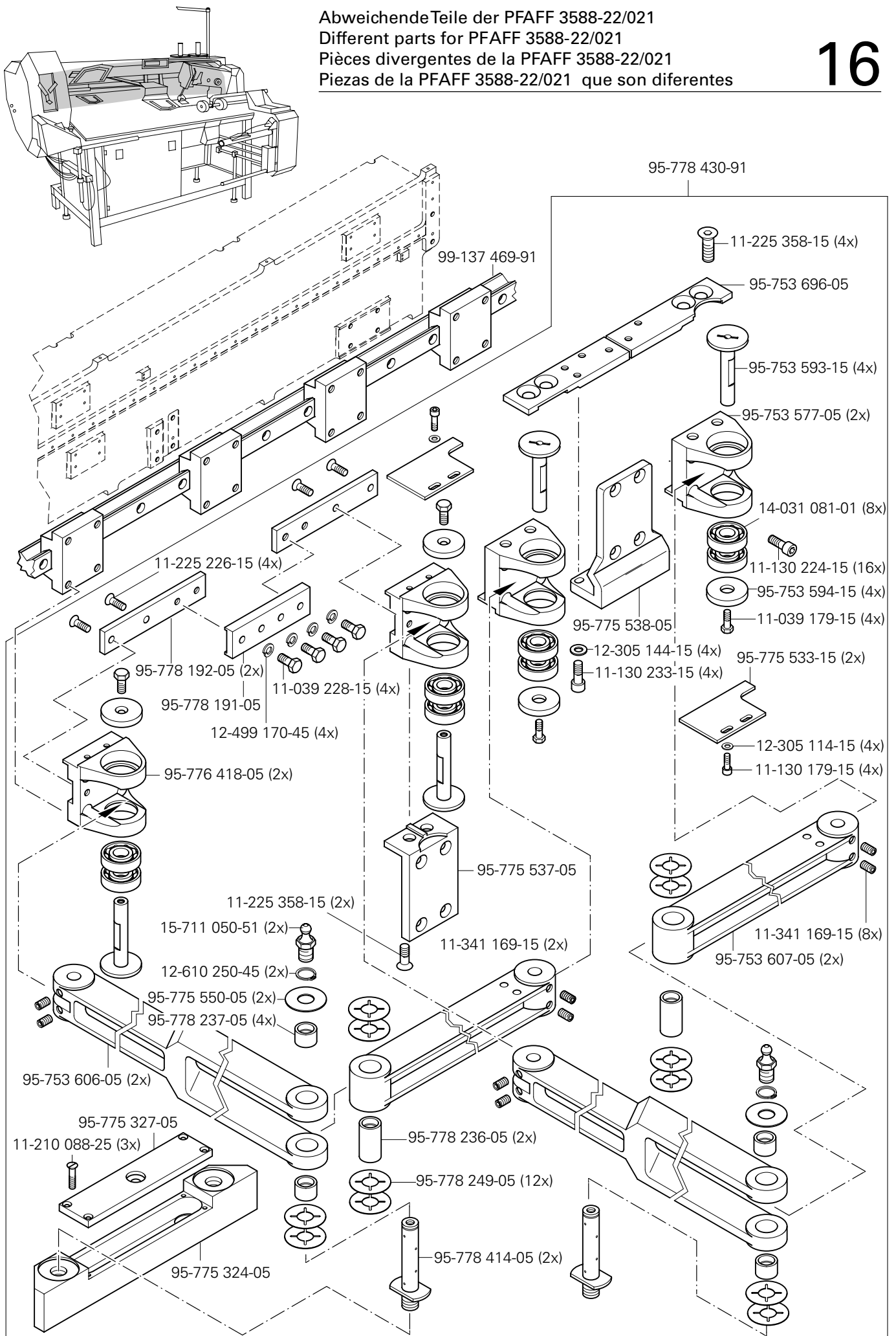

 siehe Kapitel 2 Erläuterung der Schlüsselzeichen
 see chapter 2 Explanation of key markings
 voir le chap. 2 Explication des symboles
 véase el Cap. 2 Explicaciones de los signos clave

(die sonstigen Teile wie in Register 5 bis 6)
 (for all other parts see Sections 5 to 6)
 (les autres pièces comme dans les registres 5 à 6)
 (las demás piezas como en los registros 5 al 6)

16

Abweichende Teile der PFAFF 3588-22/021
 Different parts for PFAFF 3588-22/021
 Pièces divergentes de la PFAFF 3588-22/021
 Piezas de la PFAFF 3588-22/021 que son diferentes

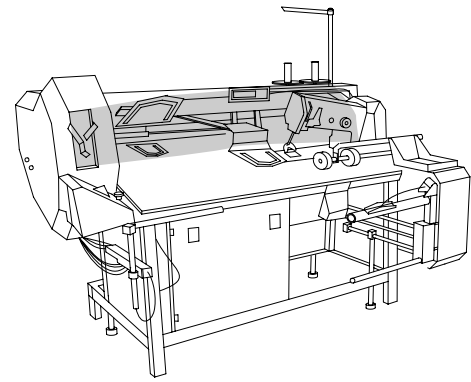

siehe Seite 16-3
 see page 16-3
 voirpage 16-3
 véase la página 16-3

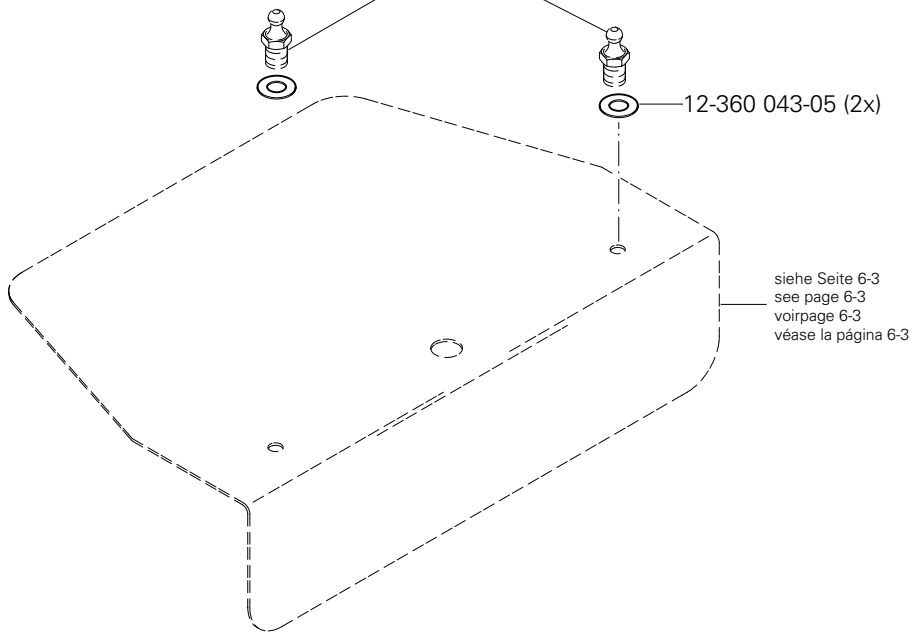

11-130 097-15 (2x)

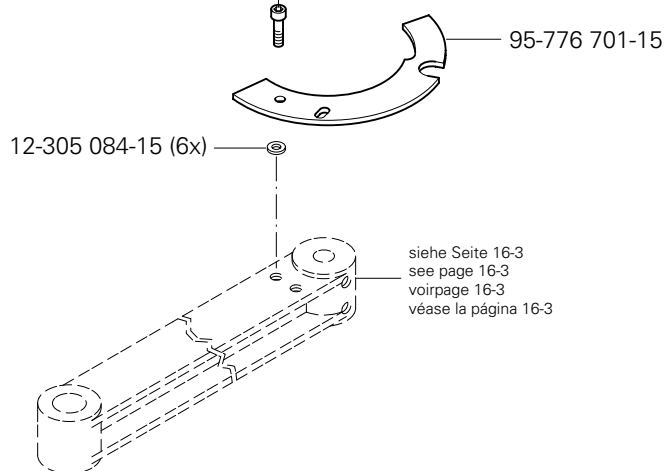

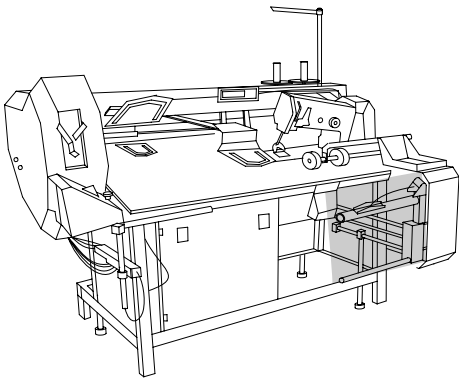

Abweichende Teile der PFAFF 3588-22/021
 Different parts for PFAFF 3588-22/021
 Pièces divergentes de la PFAFF 3588-22/021
 Piezas de la PFAFF 3588-22/021 que son diferentes

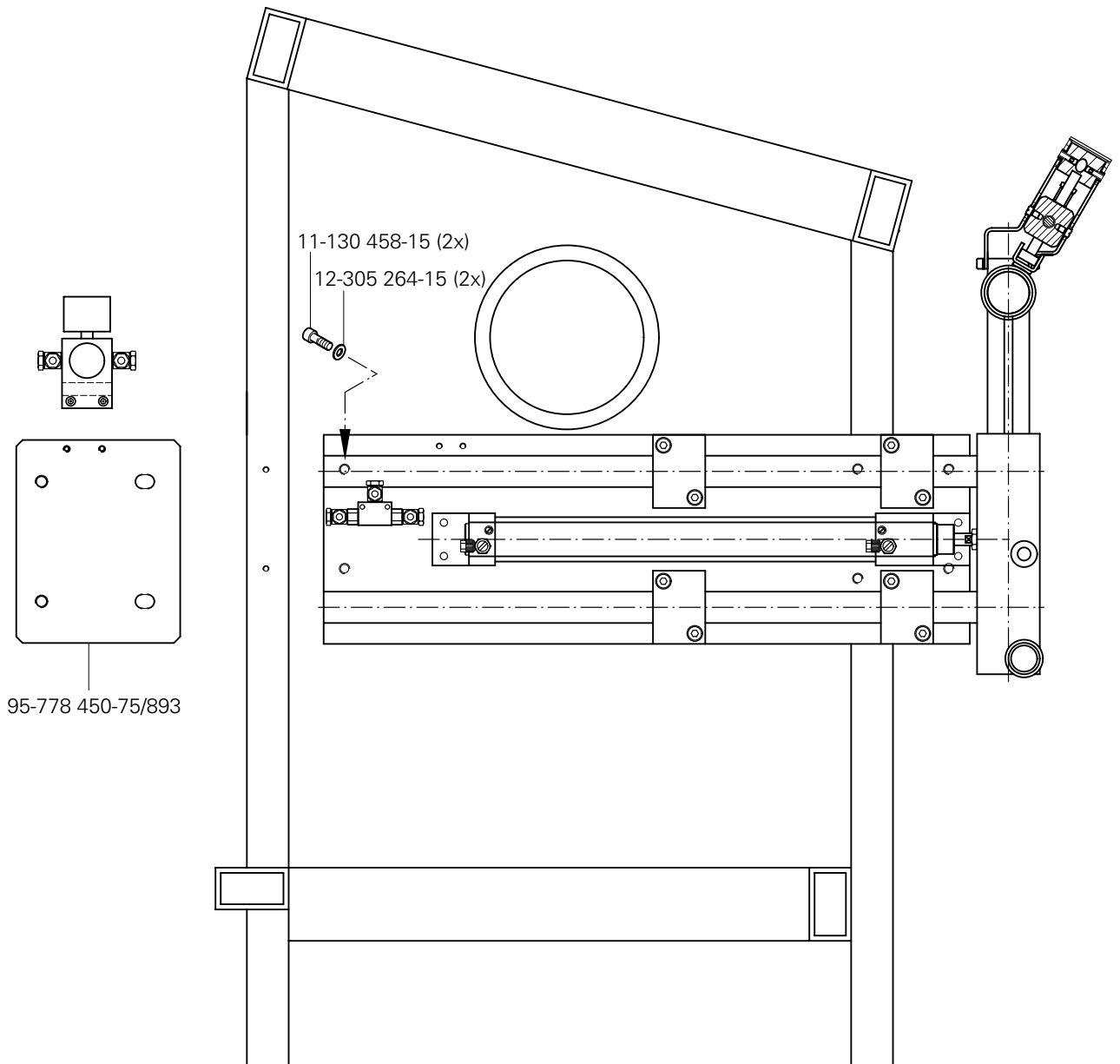

16

Abweichende Teile der PFAFF 3588-15/020
Different parts for PFAFF 3588-15/020
Pièces divergentes de la PFAFF 3588-15/020
Piezas de la PFAFF 3588-15/020 que son diferentes

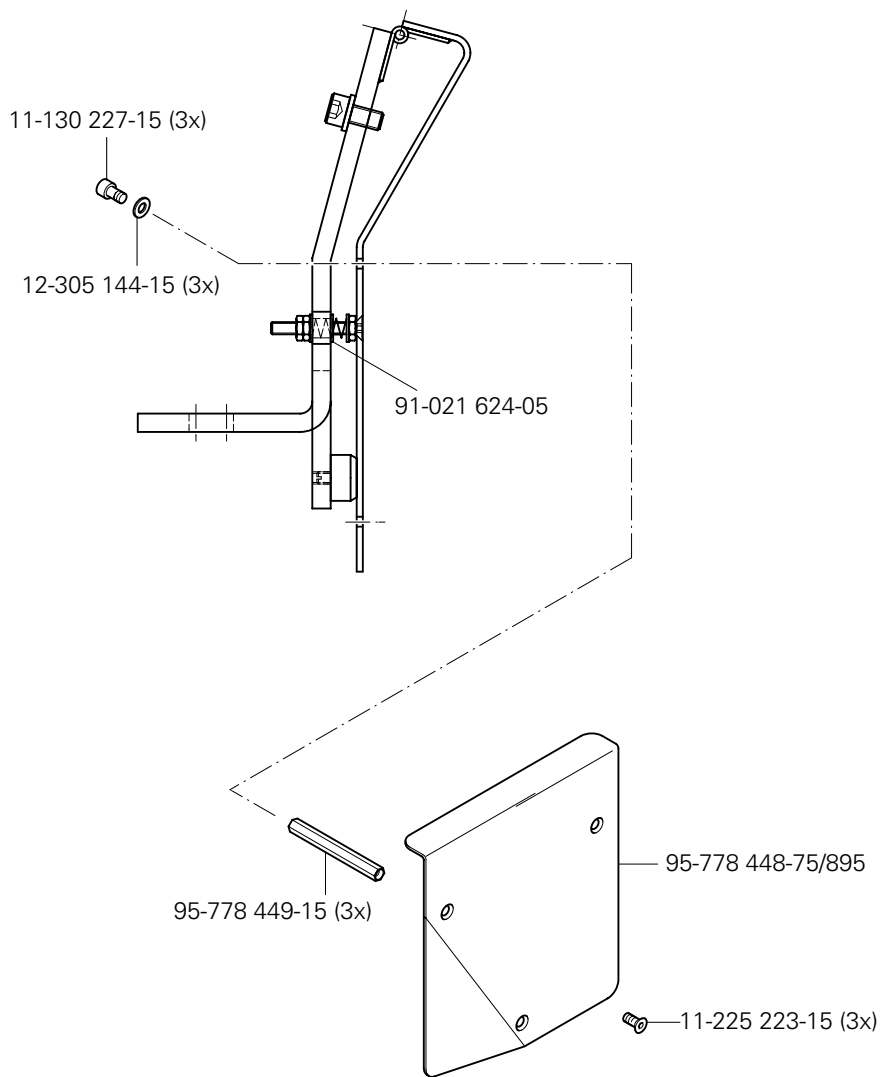
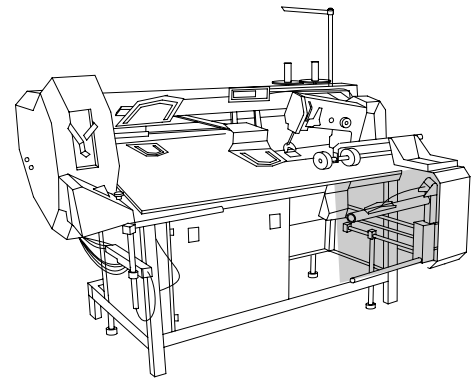

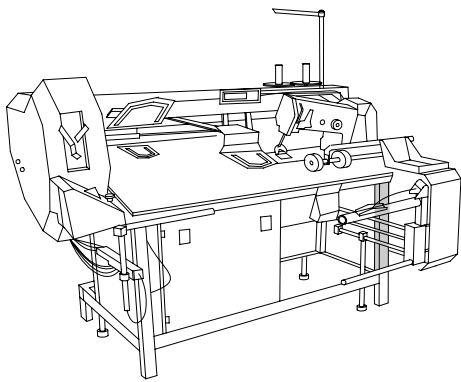

Abweichende Teile der PFAFF 3588-22/021
 Different parts for PFAFF 3588-22/021
 Pièces divergentes de la PFAFF 3588-22/021
 Piezas de la PFAFF 3588-22/021 que son diferentes

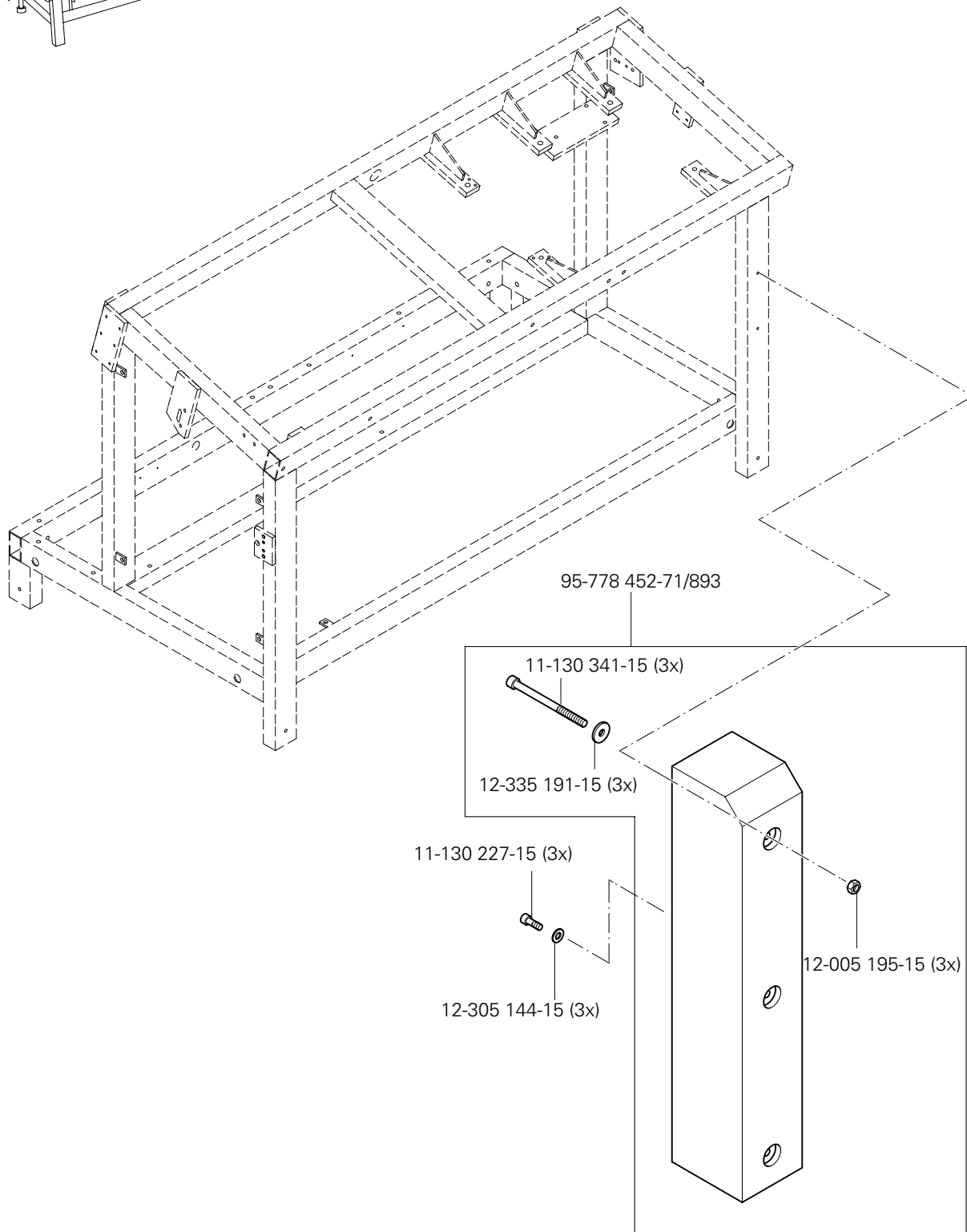

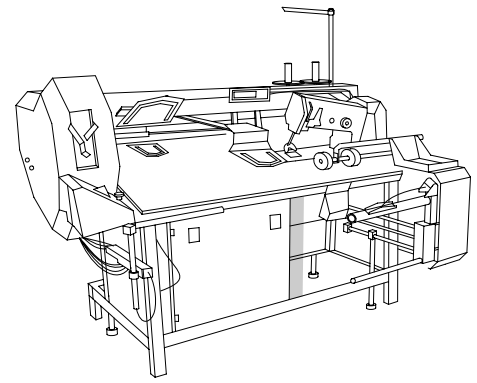

siehe Seite 3-24
 see page 3-24
 voir page 3-24
 véase la página 3-24

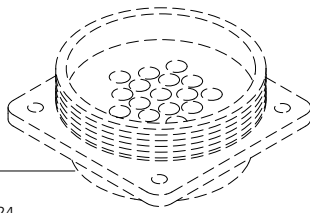

99-135 818-05

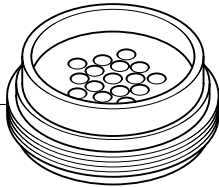

99-135 819-05

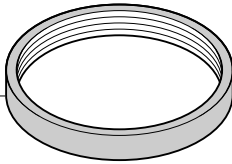

99-135 353-91 (10x)



99-135 496-95

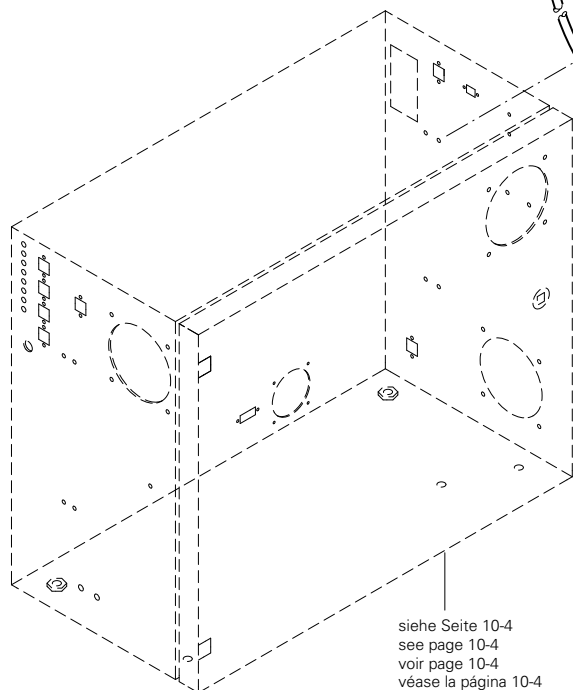

siehe Seite 10-4
 see page 10-4
 voir page 10-4
 véase la página 10-4

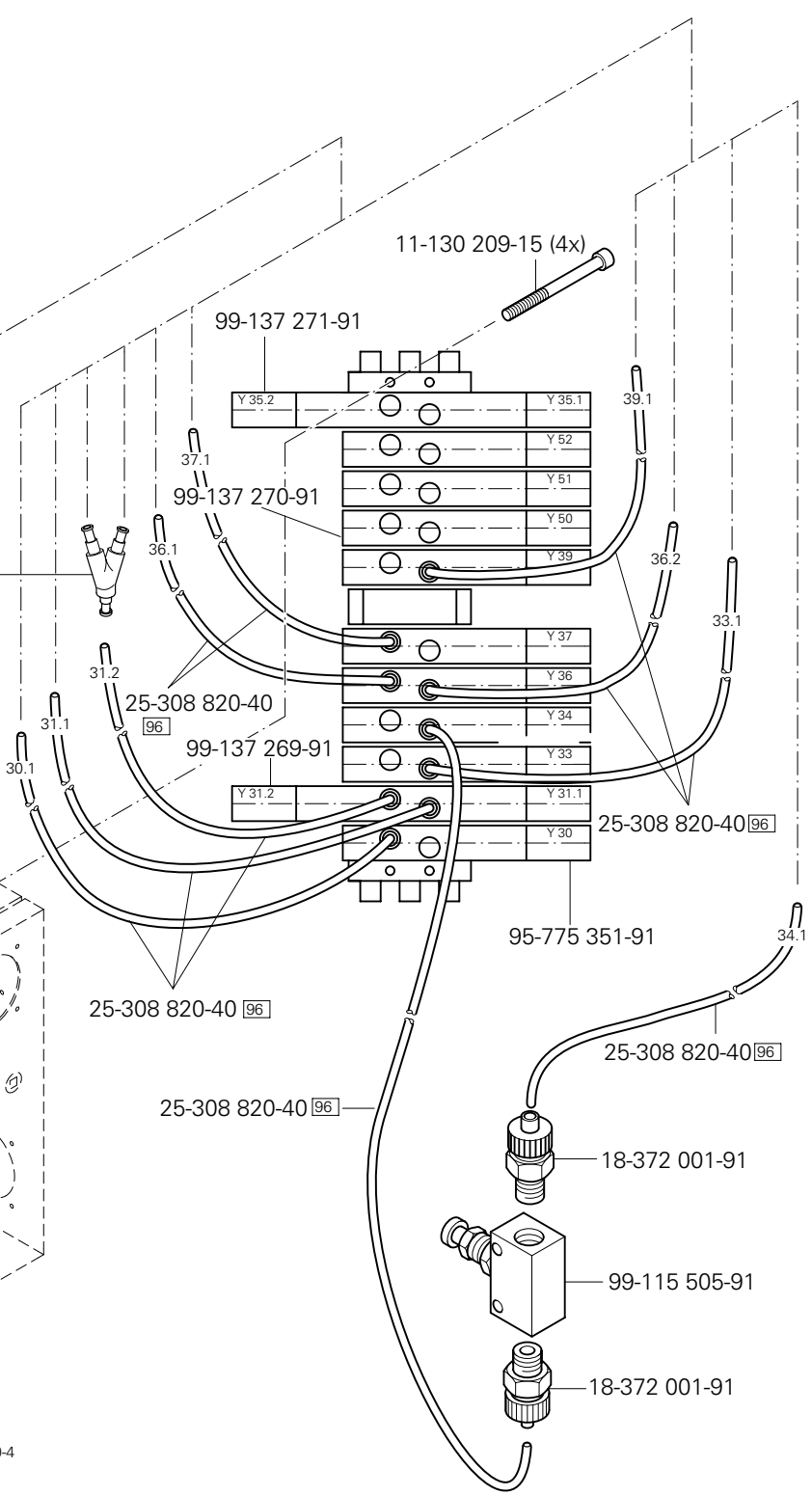

No.	Seite Page Pages Página	No.	Seite Page Pages Página	No.	Seite Page Pages Página	No.	Seite Page Pages Página
11-032 402-15	5 - 1	11-130 097-15	6 - 3, 15 - 7, 16 - 4	11-130 251-15	3 - 9, 3 - 19, 8 - 1	11-130 470-15	16 - 2
11-032 582-15	15 - 6	11-130 101-15	6 - 3	11-130 257-15	3 - 17	11-130 482-15	7 - 3
11-039 179-15	6 - 3, 6 - 4, 16 - 3	11-130 108-15	6 - 7, 15 - 28	11-130 257-25	9 - 5	11-130 494-15	16 - 2
11-039 225-15	3 - 3	11-130 110-15	15 - 30	11-130 281-15	3 - 4, 15 - 29	11-130 533-15	10 - 1, 16 - 2
11-039 228-15	8 - 6, 16 - 3	11-130 113-15	15 - 2	11-130 284-15	3 - 16, 3 - 20, 15 - 6	11-130 551-15	7 - 3
11-039 231-15	8 - 2	11-130 170-15	3 - 3, 15 - 12, 15 - 16, 5 - 20	11-130 284-25	10 - 8	11-130 557-15	8 - 1
11-039 240-15	3 - 19	11-130 173-15	3 - 20, 3 - 21, 6 - 2, 8 - 6, 8 - 7, 10 - 2, 15 - 11	11-130 287-15	3 - 1, 3 - 9, 5 - 1, 7 - 6, 15 - 28	11-130 719-15	7 - 3, 7 - 5
11-039 291-15	8 - 6	11-130 176-15	3 - 12, 3 - 15, 8 - 7, 10 - 15, 15 - 4, 15 - 12, 15 - 14, 15 - 16, 15 - 17, 15 - 18, 15 - 19, 15 - 20	11-130 293-15	3 - 19, 5 - 1, 7 - 3, 10 - 3, 15 - 2, 15 - 5, 15 - 30	11-130 906-15	3 - 9, 7 - 3, 10 - 15
11-039 318-15	8 - 5			11-130 293-25	6 - 2, 8 - 6, 8 - 7, 15 - 8	11-130 918-15	8 - 5
11-039 354-15	10 - 12			11-130 296-15	15 - 4	11-130 939-15	3 - 17
11-039 378-15	10 - 2	11-130 179-15	6 - 3, 6 - 4, 7 - 5, 10 - 15, 15 - 1, 15 - 2, 15 - 15, 15 - 16, 15 - 20, 15 - 30, 16 - 3	11-130 299-15	7 - 5, 8 - 3	11-132 169-15	3 - 4
11-039 459-15	6 - 6, 6 - 7			11-130 299-25	10 - 10	11-132 220-15	8 - 2
11-039 749-15	3 - 1	11-130 185-15	15 - 30	11-130 305-15	8 - 2, 8 - 5, 15 - 30	11-132 286-15	7 - 1
11-105 113-15	15 - 23, 15 - 24			11-130 311-15	15 - 4, 15 - 30	11-132 352-15	3 - 1
11-105 275-25	8 - 5	11-130 191-15	7 - 5, 15 - 11, 15 - 16, 15 - 20	11-130 317-15	8 - 1	11-172 127-25	3 - 4
11-108 009-25	3 - 14	11-130 197-15	15 - 3, 15 - 29	11-130 323-15	5 - 2	11-173 171-15	8 - 1, 8 - 5
11-108 084-15	3 - 14	11-130 203-15	15 - 16, 15 - 20	11-130 332-15	7 - 3	11-173 171-25	10 - 8, 10 - 10, 10 - 12
11-108 087-15	3 - 14	11-130 206-15	15 - 11, 15 - 12	11-130 341-15	15 - 10, 16 - 2, 16 - 7	11-173 177-15	3 - 2
11-108 093-25	10 - 12	11-130 209-15	9 - 1, 9 - 3, 15 - 12, 16 - 8	11-130 353-15	10 - 4	11-174 082-15	3 - 3
11-108 099-25	10 - 5, 10 - 13	11-130 224-15	3 - 5, 3 - 19, 5 - 2, 6 - 3, 6 - 4, 15 - 10, 15 - 20, 15 - 27, 16 - 2, 16 - 3	11-130 359-15	10 - 4	11-174 176-15	3 - 4
11-108 108-15	3 - 10	11-130 224-25	11 - 3	11-130 365-15	10 - 1, 15 - 4	11-174 912-15	3 - 14
11-108 171-15	15 - 19	11-130 227-15	7 - 1, 7 - 5, 15 - 27, 16 - 6, 16 - 7	11-130 371-15	8 - 6	11-180 169-25	3 - 1, 3 - 4
11-108 174-15	15 - 25, 15 - 26	11-130 227-25	11 - 3, 11 - 4	11-130 377-15	8 - 1, 8 - 7, 10 - 7, 15 - 2	11-180 175-25	3 - 4
11-108 177-25	11 - 1	11-130 233-15	3 - 1, 5 - 2, 6 - 1, 6 - 3, 6 - 5, 7 - 1, 7 - 6, 8 - 7, 10 - 15, 15 - 31, 16 - 1	11-130 383-15	8 - 1	11-180 223-25	3 - 4
11-108 219-15	3 - 16			11-130 389-15	5 - 2	11-186 976-15	15 - 17, 15 - 18
11-108 222-15	3 - 3, 3 - 14			11-130 395-15	7 - 5	11-187 028-15	8 - 6
11-108 225-15	3 - 1			11-130 452-15	5 - 1, 6 - 6, 6 - 7, 15 - 1, 15 - 2	11-210 035-15	15 - 17, 15 - 18
11-108 228-25	11 - 1			11-130 458-15	8 - 5, 16 - 5	11-210 044-25	3 - 3
11-108 255-15	3 - 7	11-130 239-15	3 - 1, 8 - 2	11-130 461-15	6 - 1, 6 - 5	11-210 074-15	15 - 23
11-108 306-15	3 - 17	11-130 239-25	11 - 2, 11 - 4	11-130 464-15	6 - 1, 6 - 5, 6 - 6, 6 - 7, 7 - 1, 8 - 1	11-210 084-25	3 - 10
11-108 315-15	3 - 17					11-210 088-25	6 - 3, 8 - 6, 8 - 7, 16 - 3
11-108 846-15	3 - 8, 3 - 15					11-210 165-15	10 - 10
11-130 089-15	3 - 4					11-210 168-15	3 - 6

No.	Seite Page Pages Página	No.	Seite Page Pages Página	No.	Seite Page Pages Página	No.	Seite Page Pages Página
11-210 169-25	10 - 6	11-330 280-15	3 - 3, 5 - 2, 7 - 3, 8 - 4, 15 - 10	11-560 190-15	15 - 31	12-305 114-15	6 - 3, 6 - 4, 7 - 6, 8 - 7, 10 - 12, 10 - 15, 15 - 4, 15 - 11, 15 - 12, 15 - 14, 15 - 16, 15 - 19, 15 - 20, 15 - 30, 16 - 3
11-225 094-15	6 - 3	11-330 283-15	3 - 1	11-724 190-55	10 - 12	12-305 114-25	10 - 8, 15 - 31
11-225 169-15	3 - 16	11-330 286-15	7 - 1	11-724 907-55	11 - 4	12-305 144-15	3 - 3, 3 - 17, 6 - 3, 7 - 1, 8 - 2, 8 - 6, 15 - 27, 16 - 3, 16 - 6, 16 - 7
11-225 169-25	15 - 24	11-330 304-15	15 - 4	12-005 154-25	3 - 4, 15 - 17, 15 - 18	12-305 144-25	9 - 5, 11 - 2, 11 - 3, 11 - 4
11-225 172-15	15 - 14, 15 - 28	11-330 352-15	3 - 1	12-005 171-15	15 - 31	12-305 174-15	5 - 2, 7 - 6, 8 - 2, 8 - 3, 8 - 6, 15 - 4, 15 - 5, 15 - 30
11-225 175-15	10 - 2	11-330 364-15	3 - 14, 6 - 1, 6 - 5	12-005 195-15	3 - 9, 8 - 1, 15 - 29, 16 - 7	12-305 174-25	3 - 4
11-225 175-25	3 - 12	11-330 370-15	8 - 1	12-005 215-15	3 - 17, 3 - 21, 8 - 6, 10 - 10, 10 - 12	12-305 221-15	10 - 1
11-225 178-15	15 - 12, 15 - 24	11-330 952-15	3 - 5, 3 - 6, 3 - 13, 3 - 18	12-010 240-15	10 - 16	12-305 224-15	5 - 1, 5 - 2, 8 - 6, 8 - 7, 10 - 4, 15 - 4
11-225 178-25	15 - 23	11-330 955-15	10 - 3	12-024 121-25	10 - 16	12-305 264-15	5 - 1, 6 - 1, 6 - 5, 6 - 6, 6 - 7, 8 - 1, 8 - 5, 15 - 1, 15 - 2, 15 - 4, 16 - 5
11-225 184-15	15 - 31	11-330 960-15	3 - 2, 3 - 5	12-024 121-15	15 - 17, 15 - 18, 15 - 30	12-305 314-15	5 - 1, 15 - 6
11-225 196-15	7 - 6, 10 - 15	11-330 962-15	3 - 3	12-024 121-25	15 - 13, 15 - 22	12-315 090-25	3 - 4
11-225 220-15	3 - 1, 7 - 3	11-330 964-15	3 - 5, 3 - 14, 3 - 15	12-024 151-15	7 - 6, 15 - 11, 15 - 30, 15 - 31	12-322 028-05	3 - 8
11-225 223-25	11 - 5, 16 - 6	11-335 085-15	3 - 14, 6 - 2	12-024 151-25	15 - 31	12-333 230-15	3 - 1
11-225 226-15	15 - 15, 16 - 3	11-335 280-15	3 - 3, 16 - 2	12-024 171-15	3 - 16, 3 - 17, 7 - 6, 10 - 15, 15 - 29	12-335 151-15	6 - 2, 8 - 6, 8 - 7, 15 - 3, 15 - 7, 15 - 15
11-225 232-15	3 - 8, 5 - 2, 6 - 3	11-335 379-15	3 - 21	12-024 171-25	3 - 19, 3 - 22, 11 - 3, 11 - 4, 11 - 5, 13 - 1, 15 - 13, 15 - 17, 15 - 18, 15 - 22, 15 - 28	12-335 171-15	4 - 1, 15 - 9, 16 - 1
11-225 238-15	6 - 1, 6 - 5, 11 - 5	11-335 902-15	3 - 5, 3 - 15, 3 - 18	12-024 172-15	3 - 17	12-335 191-15	8 - 5, 10 - 15, 16 - 7
11-225 283-15	10 - 15, 15 - 28	11-341 085-15	15 - 17, 15 - 18	12-024 191-15	6 - 6, 6 - 7, 8 - 2, 8 - 5, 10 - 15, 15 - 4, 15 - 27, 15 - 29, 15 - 30	12-335 191-25	15 - 8
11-225 292-15	15 - 28	11-341 169-15	6 - 3, 6 - 4, 6 - 6, 6 - 7, 16 - 3	12-024 191-25	3 - 6, 12 - 1, 15 - 10, 16 - 2	12-335 210-15	10 - 2
11-225 358-15	5 - 1, 6 - 3, 6 - 4, 16 - 3	11-341 217-15	3 - 8	12-024 211-15	5 - 1, 8 - 1, 15 - 4	12-349 901-05	3 - 14
11-225 364-15	8 - 2	11-341 280-15	3 - 2	12-024 231-15	6 - 6, 6 - 7, 15 - 4	12-360 040-05	10 - 15
11-225 457-15	6 - 6, 6 - 7	11-341 901-15	3 - 14	12-024 251-15	5 - 1, 15 - 6	12-360 043-25	10 - 15
11-225 902-15	3 - 8	11-341 902-15	3 - 5, 3 - 15	12-024 291-15	6 - 6, 6 - 7	12-360 124-05	3 - 22
11-225 904-05	10 - 1	11-341 905-15	3 - 5, 3 - 18	12-024 291-25	3 - 1	12-360 141-05	7 - 1
11-250 084-25	3 - 6	11-460 193-15	10 - 15	12-105 190-25	11 - 1	12-360 143-05	7 - 1
11-317 971-15	3 - 8	11-462 154-55	15 - 7	12-160 193-25	11 - 5		
11-330 082-15	10 - 16	11-462 202-55	15 - 29	12-305 084-15	6 - 3, 10 - 16, 15 - 2, 15 - 7, 15 - 13, 15 - 17, 15 - 18, 15 - 22, 15 - 30, 16 - 4		
11-330 166-15	3 - 3, 3 - 7, 3 - 13, 3 - 20, 8 - 4	11-462 205-55	15 - 29	12-305 084-25	15 - 28		
11-330 169-15	3 - 4, 3 - 15, 3 - 18, 7 - 1	11-472 193-25	4 - 1				
11-330 175-15	7 - 1	11-472 193-55	4 - 1, 15 - 9, 16 - 1				
11-330 217-15	3 - 7, 3 - 13, 6 - 1, 6 - 5	11-472 199-25	4 - 1, 16 - 1				
11-330 220-15	3 - 3, 3 - 7, 3 - 15, 7 - 1	11-472 199-55	15 - 9				
11-330 277-15	3 - 1, 3 - 15, 3 - 19, 11 - 1	11-550 223-15	11 - 1, 11 - 5				

No.	Seite Page Pages Página	No.	Seite Page Pages Página	No.	Seite Page Pages Página	No.	Seite Page Pages Página
12-360 181-05	8 - 3	12-642 901-55	15 - 21	14-016 150-01	3 - 5	16-047 131-55	3 - 22
12-360 184-05	8 - 3	12-642 902-55	15 - 20	14-016 151-91	3 - 5	16-049 020-11	3 - 17, 11 - 3, 15 - 23, 15 - 24
12-380 170-25	6 - 2, 8 - 6, 8 - 7	12-660 390-45	3 - 14	14-018 594-01	7 - 1	16-049 040-11	15 - 29
12-499 150-25	15 - 31	12-660 430-45	6 - 1, 6 - 5	14-018 640-01	8 - 2, 8 - 3	16-049 021-11	3 - 17
12-499 150-45	8 - 7, 10 - 15, 15 - 11	12-660 520-45	6 - 6, 6 - 7, 8 - 1	14-018 644-91	3 - 5	16-409 970-05	3 - 5
12-499 170-45	6 - 3, 6 - 4, 7 - 6, 16 - 3	12-660 550-45	6 - 1, 6 - 5, 8 - 2, 8 - 3, 15 - 4	14-027 902-01	15 - 23, 15 - 24	16-414 127-05	3 - 18
12-499 190-45	5 - 2, 10 - 15, 15 - 4	12-710 250-12	11 - 1	14-031 081-01	6 - 3, 6 - 4, 16 - 3	16-920 007-15	6 - 6, 6 - 7
12-499 210-45	10 - 7	12-710 270-12	3 - 3	14-031 151-01	6 - 1, 6 - 5	17-518 010-51	9 - 6
12-499 230-45	6 - 1, 6 - 5, 6 - 6, 6 - 7, 8 - 1, 15 - 1, 15 - 2	13-030 530-05	3 - 20	14-215 022-33	3 - 8	18-278 001-91	3 - 11, 15 - 30
12-499 290-45	7 - 3	13-030 635-05	3 - 1	14-215 043-13	3 - 13	18-278 005-91	3 - 9
12-500 151-45	15 - 16, 15 - 20	13-030 641-05	3 - 1	14-215 091-13	3 - 3	18-372 001-91	3 - 11, 8 - 4, 9 - 2, 9 - 4, 16 - 8
12-501 150-45	7 - 5	13-033 091-05	3 - 4	14-215 166-03	3 - 3	18-372 004-91	9 - 5
12-501 170-45	7 - 5, 8 - 2, 8 - 7	13-033 109-05	3 - 4	14-218 050-01	3 - 8, 6 - 1, 6 - 5	18-372 008-91	3 - 16, 8 - 4, 15 - 25, 15 - 26
12-501 190-45	7 - 3, 8 - 2	13-033 190-05	3 - 14	14-218 090-01	3 - 8, 6 - 3, 6 - 4	18-373 011-91	3 - 9
12-501 210-45	7 - 5, 8 - 1	13-033 262-05	15 - 24	14-310 240-01	15 - 1, 15 - 2	18-378 001-91	8 - 4, 8 - 5
12-501 230-45	7 - 3	13-033 307-05	15 - 4	14-602 901-01	3 - 6	18-378 004-91	9 - 5
12-505 171-15	7 - 5	13-033 400-05	6 - 1, 6 - 5	14-680 030-15	3 - 15	18-378 008-91	15 - 12, 15 - 16, 15 - 20
12-510 111-25	10 - 10	13-033 460-05	3 - 16	14-680 420-15	3 - 15, 3 - 18	18-379 004-91	9 - 5
12-512 170-25	10 - 10	13-033 490-05	6 - 6, 6 - 7	14-731 451-05	7 - 1	18-381 002-91	9 - 6
12-512 220-05	10 - 10	13-033 544-05	8 - 4	14-731 915-05	6 - 6, 6 - 7	24-101 220-54	7 - 6
12-517 250-45	6 - 1, 6 - 5	13-033 568-05	3 - 7	14-757 131-01	6 - 6, 6 - 7, 8 - 1, 8 - 5	24-101 230-64	10 - 5
12-610 200-45	3 - 15	13-052 088-55	3 - 15	15-032 001-45	3 - 9, 3 - 11	24-162 253-44	10 - 3
12-610 210-45	3 - 3, 6 - 1, 6 - 5	13-052 247-15	8 - 6	15-032 002-45	9 - 6	25-161 801-49	3 - 14
12-610 230-45	3 - 14	13-063 193-05	3 - 14	15-032 006-45	3 - 4, 3 - 19, 15 - 27	25-161 801-51	3 - 7
12-610 250-45	6 - 3, 6 - 4, 16 - 3	14-010 570-01	3 - 14	15-120 709-05	3 - 17	25-161 801-52	3 - 14, 3 - 16
12-610 270-45	15 - 4	14-010 665-01	15 - 4	15-120 712-05	3 - 17	25-161 805-04	9 - 6
12-610 310-45	3 - 3	14-016 080-01	3 - 14	15-120 924-05	3 - 15	25-308 820-30	3 - 2, 3 - 4, 3 - 9, 15 - 12, 15 - 19, 15 - 23, 15 - 24, 15 - 25, 15 - 26, 15 - 27
12-610 330-45	8 - 3	14-016 101-91	3 - 15, 3 - 18	15-125 049-05	3 - 16	25-308 820-40	3 - 11, 3 - 17, 8 - 4, 9 - 1, 9 - 2, 9 - 3, 9 - 4, 9 - 5, 10 - 16, 15 - 17, 15 - 18, 15 - 19, 15 - 25, 15 - 26, 16 - 8
12-610 380-45	3 - 1	14-016 103-01	3 - 15, 3 - 18	15-711 050-51	16 - 3		
12-610 570-45	15 - 1, 15 - 2	14-016 120-01	6 - 1, 6 - 5	16-042 050-15	15 - 29		
12-618 190-45	3 - 6	14-016 131-91	3 - 15	16-042 903-01	7 - 1		
12-640 130-55	3 - 4, 3 - 6	14-016 133-01	3 - 15	16-047 020-15	11 - 3, 15 - 23, 15 - 24		

No.	Seite Page Pages Página	No.	Seite Page Pages Página	No.	Seite Page Pages Página	No.	Seite Page Pages Página
25-308 820-60	9 - 1, 9 - 5	71-190 000-60	10 - 10	91-002 061-05	3 - 4	91-119 705-12	3 - 5
25-405 604-11	15 - 14	71-190 001-18	10 - 10	91-002 134-05	3 - 14	91-119 763-05	3 - 3
25-405 604-12	15 - 14	71-190 002-13	10 - 10	91-002 262-25	3 - 4	91-129 668-25	12 - 1
25-405 604-33	15 - 14	71-210 002-21	10 - 10	91-006 525-05	3 - 2	91-129 669-75/69812	- 1
25-901 610-03	10 - 3	71-210 002-40	10 - 10	91-006 526-05	3 - 2	91-129 670-45	12 - 1
26-536 301-09	3 - 14, 3 - 16	71-210 002-50	10 - 10	91-006 814-05	3 - 4	91-129 671-05	12 - 1
26-536 302-09	3 - 13	71-210 002-52	10 - 10	91-009 026-05	3 - 14	91-129 917-91	14 - 1
28-011 201-44	14 - 1	71-370 001-31	6 - 7	91-009 076-61	3 - 14	91-141 961-91	3 - 14
28-011 202-05	14 - 1	71-370 001-33	15 - 19	91-011 909-05	6 - 2, 8 - 6, 8 - 7	91-161 268-96	3 - 13
28-011 202-10	14 - 1	71-370 001-36	15 - 25, 15 - 26	91-014 346-05	3 - 4	91-164 902-01	3 - 3
28-011 202-43	14 - 1	71-370 001-58	7 - 6	91-020 324-05	15 - 30	91-165 505-05	3 - 14
28-011 202-47	14 - 1	71-370 001-59	10 - 6, 10 - 15, 15 - 4	91-021 624-05	16 - 6	91-165 685-05	3 - 14
28-911 200-42	15 - 14	71-370 001-75	10 - 6	91-022 116-05	7 - 6	91-165 745-15	3 - 14
29-013 660-01	15 - 14	71-480 000-12	10 - 10	91-024 554-05	7 - 6	91-166 034-01	3 - 2
49-031 450-02	10 - 16	71-520 005-17	10 - 7	91-031 888-15	10 - 15, 15 - 29	91-166 037-15	3 - 2
70-371 500-02	7 - 6	71-520 005-19	7 - 1	91-056 192-25	3 - 4	91-166 452-21	3 - 6
71-110 003-07	10 - 4	71-520 005-20	15 - 4	91-056 193-25	3 - 4	91-166 520-05	3 - 3
71-120 005-32	7 - 6	71-523 555-34	10 - 2	91-056 578-91	3 - 6	91-166 521-05	3 - 3
71-120 006-32	3 - 10, 15 - 2, 15 - 23, 15 - 24	71-590 007-11	10 - 10	91-056 760-05	3 - 4	91-166 529-05	3 - 8
71-130 004-39	10 - 3	71-710 000-82	10 - 10	91-069 062-45	3 - 15	91-166 531-05	3 - 8
71-130 004-40	10 - 3	71-750 002-46	10 - 8	91-069 240-05	3 - 15	91-166 532-05	3 - 8
71-130 005-52	6 - 3, 6 - 7	71-750 002-76	10 - 7	91-069 241-05	3 - 15	91-166 589-05	3 - 7
71-130 006-42	15 - 7	71-750 007-03	10 - 1	91-069 709-12	3 - 8	91-166 915-05	3 - 2
71-140 000-41	3 - 22	71-760 004-99	10 - 4	91-100 270-25	15 - 25, 15 - 26	91-167 435-05	3 - 14
71-150 000-69	10 - 10	71-890 000-09	10 - 4	91-100 343-15	15 - 23, 15 - 24, 15 - 27	91-168 144-05	3 - 14
71-160 001-39	10 - 5, 10 - 13	71-890 000-14	10 - 1	91-100 355-05	3 - 3	91-168 194-71/698	3 - 4
71-160 001-40	15 - 4	71-910 000-34	10 - 13	91-105 447-25	3 - 4	91-168 258-92	3 - 15
71-160 001-65	10 - 15	71-910 000-49	10 - 6	91-118 430-25	3 - 4	91-169 245-91	3 - 14
71-160 003-37	10 - 15, 15 - 4	71-910 000-50	10 - 13	91-118 518-05	3 - 3	91-170 228-91	3 - 5
71-160 003-38	10 - 5, 10 - 13	71-910 000-52	10 - 15	91-118 570-92	3 - 5	91-170 229-11	3 - 5
71-160 003-80	10 - 4, 10 - 13	91-000 250-15	3 - 14	91-118 683-05	3 - 6	91-170 811-92	3 - 18
71-160 008-14	10 - 3	91-000 390-05	3 - 14	91-119 015-15	3 - 3	91-171 049-05	3 - 6
71-170 002-27	10 - 15	91-000 407-15	3 - 13	91-119 704-91	3 - 5	91-171 104-91	3 - 15

No.	Seite Page Pages Página	No.	Seite Page Pages Página	No.	Seite Page Pages Página	No.	Seite Page Pages Página
91-171 162-91	3 - 15	91-176 378-05	3 - 4	91-291 483-91	10 - 7	91-291 520-91	7 - 1
91-171 173-92	3 - 14	91-176 431-05	3 - 4	91-291 484-91	10 - 14	91-291 521-91	7 - 1
91-171 182-15	3 - 12	91-176 464-05	3 - 4	91-291 485-91	10 - 6	91-291 549-05	10 - 10
91-171 502-91	3 - 16	91-176 615-12	3 - 13	91-291 487-91	10 - 10	91-291 550-05	10 - 10
91-171 529-15	3 - 16	91-229 070-70/895	12 - 1	91-291 488-91	7 - 1	91-291 551-05	10 - 12
91-171 531-91	3 - 16	91-264 357-05	3 - 6	91-291 489-91	10 - 10	91-291 552-05	10 - 12
91-171 785-05	3 - 14	91-264 358-05	3 - 6	91-291 490-91	10 - 7	91-291 553-05	10 - 12
91-171 797-05	3 - 14	91-265 045-05	3 - 13	91-291 491-91	10 - 8	91-291 554-05	10 - 8
91-171 850-91	3 - 14	91-265 065-05	3 - 14	91-291 492-91	10 - 10	91-291 555-91	3 - 11
91-171 851-05	3 - 14	91-265 206-91	3 - 14	91-291 494-91	10 - 4	91-291 566-91	10 - 13
91-171 853-15	3 - 14	91-265 207-91	3 - 14	91-291 496-91	10 - 7	91-291 582-91	15 - 2
91-171 854-15	3 - 14	91-265 208-05	3 - 14	91-291 497-91	10 - 4	91-291 583-91	15 - 4
91-171 874-12	3 - 15	91-265 209-91	3 - 14	91-291 498-91	10 - 10	91-291 586-93/001	10 - 10
91-171 875-12	3 - 8, 3 - 15	91-265 210-05	3 - 14	91-291 499-91	10 - 8	91-291 593-91	7 - 6
91-171 939-05	3 - 15	91-265 217-11	3 - 17	91-291 500-91	10 - 13	91-291 594-91	10 - 2
91-174 058-11	3 - 17	91-265 227-05	3 - 14	91-291 501-91	3 - 22	91-291 595-71/895	10 - 3
91-174 060-12	3 - 17	91-266 335-01	3 - 3	91-291 502-91	3 - 20	91-291 597-91	10 - 13
91-174 067-15	3 - 17	91-266 353-05	3 - 4	91-291 503-91	10 - 12	91-291 630-91	6 - 3
91-174 501-15	3 - 1	91-266 410-25	3 - 4	91-291 504-91	10 - 14	91-291 631-91	6 - 3
91-174 582-05	3 - 17	91-266 414-05	3 - 4	91-291 505-91	10 - 1	91-291 632-91	6 - 3
91-174 680-91	3 - 15	91-266 456-91	3 - 4	91-291 506-91	10 - 4	91-291 647-91	10 - 5
91-174 740-11	3 - 16	91-266 545-91	3 - 3	91-291 507-91	10 - 5	91-291 650-91	10 - 5
91-174 879-05	3 - 6	91-266 651-05	3 - 3	91-291 508-91	10 - 5	91-291 674-45	10 - 10
91-175 690-05	3 - 14	91-266 727-05	3 - 3	91-291 509-91	10 - 13	91-291 676-91	15 - 23, 15 - 24
91-175 838-15	3 - 14	91-266 757-05	3 - 4	91-291 510-91	10 - 5	91-291 702-91	15 - 27
91-176 199-92	3 - 3	91-268 076-15	3 - 14	91-291 511-91	10 - 10	91-291 704-91	15 - 25, 15 - 26
91-176 204-05	3 - 3	91-280 078-75/895	3 - 1	91-291 512-91	9 - 6	91-291 707-91	10 - 13
91-176 302-05	3 - 3	91-290 112-91	10 - 7	91-291 514-91	10 - 12	91-291 751-91	10 - 8
91-176 309-05	3 - 3	91-290 577-91	10 - 7	91-291 515-91	10 - 10	91-291 760-91	10 - 4
91-176 315-05	3 - 3	91-290 732-91	10 - 7	91-291 516-05	10 - 10	91-291 768-91	10 - 8
91-176 324-25	3 - 4	91-291 133-91	3 - 4	91-291 517-05	10 - 10	91-291 907-93/0013	10
91-176 332-25	3 - 4	91-291 362-93/001	10 - 12	91-291 518-91	6 - 7	91-291 919-91	15 - 8
91-176 377-25	3 - 4	91-291 482-91	10 - 7	91-291 519-91	6 - 7	91-291 920-90	15 - 8

No.	Seite Page Pages Página	No.	Seite Page Pages Página	No.	Seite Page Pages Página	No.	Seite Page Pages Página
91-291 930-90	15 - 7	95-215 040-12/561	7 - 3	95-215 040-15/145	8 - 2	95-215 080-19/223	8 - 2
91-291 932-91	15 - 7	95-215 040-12/569	7 - 5	95-215 040-15/147	8 - 7	95-215 080-23/601	7 - 5
91-292 341-91	10 - 1	95-215 040-13/534	7 - 5	95-215 040-15/149	8 - 6	95-215 080-29/013	7 - 3
91-292 350-71/699	10 - 1	95-215 040-13/535	7 - 3	95-215 040-15/323	6 - 2, 8 - 6, 8 - 7	95-215 080-34/713	8 - 2
91-292 393-91	10 - 7	95-215 040-13/591	7 - 3	95-215 040-15/324	8 - 5	95-215 080-35/005	8 - 2
91-292 394-91	10 - 7	95-215 040-13/877	7 - 3	95-215 040-15/325	8 - 1	95-215 080-35/201	8 - 2
91-292 395-91	10 - 7	95-215 040-13/878	7 - 3	95-215 040-15/326	8 - 2	95-215 080-35/202	8 - 2
91-292 396-91	10 - 7	95-215 040-13/880	7 - 5	95-215 040-15/327	8 - 2	95-215 080-58/401	8 - 2
91-292 397-91	10 - 7	95-215 040-13/892	15 - 30	95-215 040-15/357	8 - 1	95-560 274-75/940	10 - 5
91-292 398-91	10 - 7	95-215 040-13/921	7 - 3	95-215 040-15/381	6 - 7	95-623 330-03/001	3 - 13
91-292 399-75/891	10 - 1	95-215 040-13/923	7 - 3	95-215 040-15/383	8 - 4	95-623 330-03/002	3 - 13
91-700 335-25	6 - 2, 6 - 7, 15 - 23, 15 - 24	95-215 040-14/132	7 - 3	95-215 040-15/384	8 - 4	95-623 330-03/003	3 - 13
91-700 510-15	3 - 5	95-215 040-14/133	7 - 3	95-215 040-15/386	6 - 7	95-623 330-03/004	3 - 13
91-700 785-15	3 - 2	95-215 040-14/134	7 - 3	95-215 040-17/160	8 - 2	95-623 330-03/005	3 - 13
91-700 996-15	3 - 6	95-215 040-14/135	7 - 5	95-215 040-18/505	7 - 5	95-623 330-03/006	3 - 13
91-701 344-25	10 - 16	95-215 040-14/136	7 - 3	95-215 040-23/457	8 - 2	95-623 330-03/007	3 - 13
91-701 522-25	3 - 4	95-215 040-14/138	7 - 5	95-215 040-24/856	8 - 2	95-633 660-91	9 - 6
95-215 000-00/556	15 - 30	95-215 040-14/141	7 - 3	95-215 040-24/859	8 - 2	95-665 735-91	14 - 1
95-215 000-00/635	7 - 3	95-215 040-14/143	7 - 3	95-215 040-24/860	8 - 2	95-711 645-11	15 - 31
95-215 000-03/299	7 - 3	95-215 040-14/146	7 - 3	95-215 070-04/608	8 - 4, 15 - 30	95-714 813-05	11 - 1
95-215 000-03/413	7 - 5	95-215 040-14/150	15 - 30	95-215 070-05/901	7 - 3, 8 - 1	95-716 888-05	15 - 30
95-215 000-03/416	15 - 30	95-215 040-14/151	15 - 30	95-215 070-07/112	8 - 1	95-730 065-15	15 - 29
95-215 000-03/417	15 - 30	95-215 040-14/152	15 - 30	95-215 070-42/609	8 - 4	95-753 342-15	10 - 3
95-215 000-03/608	15 - 30	95-215 040-14/161	7 - 5	95-215 080-06/501	8 - 1	95-753 564-05	15 - 16, 15 - 20
95-215 000-03/636	8 - 1	95-215 040-14/174	8 - 2	95-215 080-08/921	8 - 4	95-753 577-05	6 - 3, 6 - 4, 16 - 3
95-215 000-03/637	8 - 1	95-215 040-14/175	8 - 1	95-215 080-08/957	15 - 30	95-753 578-75/893	6 - 1, 6 - 5
95-215 000-03/638	8 - 5	95-215 040-14/177	8 - 4	95-215 080-14/925	7 - 5	95-753 593-15	6 - 3, 6 - 4, 16 - 3
95-215 000-03/992	7 - 3	95-215 040-15/131	7 - 5	95-215 080-17/604	7 - 5	95-753 594-15	6 - 3, 6 - 4, 16 - 3
95-215 000-05/039	8 - 4	95-215 040-15/132	8 - 5	95-215 080-17/605	7 - 5	95-753 595-05	6 - 6, 6 - 7
95-215 040-04/671	6 - 2, 8 - 6, 8 - 7	95-215 040-15/133	8 - 3	95-215 080-18/002	15 - 30	95-753 596-15	6 - 6, 6 - 7
95-215 040-08/763	6 - 2, 8 - 6, 8 - 7	95-215 040-15/136	8 - 6	95-215 080-18/007	8 - 1, 8 - 4	95-753 597-05	6 - 6, 6 - 7
95-215 040-08/768	8 - 2	95-215 040-15/141	8 - 1	95-215 080-18/008	7 - 3, 8 - 1	95-753 599-11	5 - 1
95-215 040-12/556	7 - 3	95-215 040-15/143	8 - 3	95-215 080-18/102	7 - 5	95-753 606-05	6 - 4, 16 - 3

No.	Seite Page Pages Página	No.	Seite Page Pages Página	No.	Seite Page Pages Página	No.	Seite Page Pages Página
95-753 607-05	6 - 3, 6 - 4, 16 - 3	95-775 382-71/895	8 - 3	95-775 471-05	3 - 19	95-775 536-05	6 - 3
95-753 608-47	15 - 28	95-775 383-71/895	8 - 1	95-775 472-92	3 - 7	95-775 537-05	6 - 3, 16 - 3
95-753 621-05	6 - 1	95-775 400-71/895	3 - 1	95-775 473-90	3 - 5	95-775 538-05	6 - 3, 16 - 3
95-753 637-05	6 - 1, 6 - 5	95-775 401-75/895	3 - 1	95-775 476-05	3 - 7	95-775 540-11	6 - 1, 6 - 5
95-753 638-05	6 - 1, 6 - 5	95-775 404-75/895	3 - 1	95-775 477-91	3 - 19	95-775 541-91	6 - 1, 6 - 5
95-753 646-05	6 - 1, 6 - 5	95-775 419-05	3 - 13	95-775 481-05	3 - 3	95-775 542-75/893	6 - 1, 6 - 5
95-753 650-91	6 - 1, 6 - 5	95-775 420-91	3 - 13	95-775 495-05	3 - 7	95-775 543-71/893	6 - 1, 6 - 5
95-753 651-91	6 - 1, 6 - 5	95-775 421-91	3 - 5	95-775 497-15	3 - 21	95-775 544-71/893	6 - 1, 6 - 5
95-753 696-05	6 - 4, 16 - 3	95-775 422-91	3 - 5	95-775 498-05	3 - 13	95-775 545-71/893	6 - 6, 6 - 7
95-753 907-75/895	15 - 19	95-775 424-91	3 - 3	95-775 499-15	3 - 19	95-775 546-15	6 - 6, 6 - 7
95-774 464-25	3 - 6	95-775 425-01	3 - 3	95-775 500-05	3 - 9	95-775 547-05	6 - 3
95-774 466-91	3 - 6	95-775 427-05	3 - 1	95-775 501-75/893	6 - 6, 6 - 7	95-775 548-05	6 - 4
95-774 726-91	3 - 14	95-775 428-05	3 - 19	95-775 502-71/893	5 - 1	95-775 549-01	6 - 4
95-775 228-15	15 - 16, 15 - 20	95-775 429-92	3 - 2	95-775 504-05	6 - 6, 6 - 7	95-775 550-05	6 - 3, 6 - 4, 16 - 3
95-775 229-25	15 - 12, 15 - 16, 15 - 20	95-775 431-91	3 - 19	95-775 505-75/893	6 - 6, 6 - 7	95-775 555-75/893	5 - 1
95-775 258-71/895	8 - 7	95-775 432-91	3 - 15, 3 - 18	95-775 506-75/893	6 - 6, 6 - 7	95-775 556-75/893	5 - 1
95-775 259-71/895	8 - 6	95-775 433-05	3 - 9	95-775 509-05	15 - 1, 15 - 2	95-775 557-70/893	15 - 30
95-775 311-15	7 - 1	95-775 434-15	3 - 9	95-775 511-15	15 - 1, 15 - 2	95-775 561-05	8 - 1
95-775 324-05	6 - 3, 16 - 3	95-775 435-92	3 - 8	95-775 512-05	6 - 6, 6 - 7	95-775 569-05	4 - 1
95-775 327-05	6 - 3, 8 - 7, 16 - 3	95-775 436-05	3 - 8	95-775 513-05	6 - 1, 6 - 5	95-775 571-05	6 - 5
95-775 328-05	15 - 14, 15 - 28	95-775 437-15	3 - 19	95-775 514-05	15 - 1, 15 - 2	95-775 572-05	6 - 1
95-775 329-90	6 - 2, 8 - 6, 8 - 7	95-775 438-05	3 - 19	95-775 516-15	15 - 4	95-775 577-15	15 - 15
95-775 340-71/895	7 - 1	95-775 441-15	3 - 1	95-775 518-05	15 - 1, 15 - 2	95-775 578-15	15 - 15
95-775 346-75/895	7 - 1	95-775 442-15	3 - 1	95-775 520-91	15 - 1, 15 - 2	95-775 579-15	15 - 12
95-775 347-15	7 - 1	95-775 445-05	3 - 18	95-775 525-15	15 - 4	95-775 580-04/060	15 - 12
95-775 349-15	7 - 1	95-775 446-12	3 - 18	95-775 527-15	15 - 4	95-775 580-04/080	15 - 12
95-775 350-91	9 - 1	95-775 447-91	3 - 11	95-775 529-75/893	15 - 4	95-775 580-04/100	15 - 12
95-775 351-91	16 - 8	95-775 449-75/898	3 - 1	95-775 530-05	15 - 4	95-775 580-04/120	15 - 12
95-775 352-15	7 - 1	95-775 450-05	3 - 3	95-775 531-05	15 - 4	95-775 580-04/140	15 - 12
95-775 353-75/895	7 - 1	95-775 467-92	3 - 1	95-775 532-05	15 - 4	95-775 580-04/160	15 - 12
95-775 357-15	13 - 1, 15 - 13, 15 - 22, 15 - 28	95-775 468-05	3 - 1	95-775 533-15	6 - 3, 6 - 4, 16 - 3	95-775 580-04/180	15 - 12
95-775 361-15	15 - 22	95-775 469-75/895	3 - 1	95-775 534-91	5 - 2	95-775 580-04/240	15 - 12
95-775 369-01	15 - 28	95-775 470-05	3 - 19	95-775 535-01	6 - 1, 6 - 5	95-775 580-04/260	15 - 12

No.	Seite Page Pages Página	No.	Seite Page Pages Página	No.	Seite Page Pages Página	No.	Seite Page Pages Página
95-775 581-15	5 - 2	95-775 732-05	11 - 3	95-775 905-15	3 - 22	95-776 211-15	6 - 3
95-775 582-15	5 - 2	95-775 733-05	11 - 4	95-775 908-11	3 - 5	95-776 233-04/001	15 - 27
95-775 583-15	15 - 15	95-775 735-75/895	11 - 1	95-775 912-11	3 - 18	95-776 233-04/002	15 - 27
95-775 584-15	15 - 15,15 - 21	95-775 741-05	3 - 12	95-775 913-15	13 - 1	95-776 233-04/003	15 - 27
95-775 588-05	15 - 16,15 - 20	95-775 751-75/895	11 - 2	95-775 914-91	3 - 5	95-776 233-04/004	15 - 27
95-775 589-91	15 - 12,15 - 16, 15 - 20	95-775 752-75/895	11 - 2	95-775 915-05	3 - 8	95-776 233-04/005	15 - 27
95-775 591-05	15 - 16,15 - 20	95-775 753-91	3 - 2	95-775 919-05	3 - 7, 3 - 20	95-776 240-05	15 - 27
95-775 594-15	15 - 15	95-775 757-05	15 - 14	95-775 921-11	3 - 20	95-776 276-05	15 - 23,15 - 24
95-775 595-91	15 - 15	95-775 758-15	15 - 7	95-775 937-25	3 - 4	95-776 296-71/893	10 - 3
95-775 606-71/893	5 - 1	95-775 762-91	9 - 3	95-775 940-01	3 - 16	95-776 298-71/893	10 - 3
95-775 607-71/893	5 - 1	95-775 763-04/060	15 - 12	95-775 943-91	3 - 9	95-776 299-05	5 - 2
95-775 610-71/893	5 - 1	95-775 763-04/080	15 - 12	95-775 945-91	3 - 11	95-776 300-05	11 - 1
95-775 612-15	5 - 1	95-775 763-04/100	15 - 12	95-776 015-91	15 - 3	95-776 304-71/893	15 - 11
95-775 613-15	6 - 1, 6 - 5	95-775 763-04/120	15 - 12	95-776 025-05	11 - 1	95-776 326-92	11 - 1
95-775 614-71/893	5 - 1	95-775 763-04/140	15 - 12	95-776 042-91	10 - 1	95-776 327-05	11 - 5
95-775 620-15	6 - 1, 6 - 5	95-775 763-04/160	15 - 12	95-776 060-15	6 - 6, 6 - 7	95-776 351-71/893	5 - 2
95-775 644-71/895	7 - 6	95-775 763-04/180	15 - 12	95-776 062-05	4 - 1	95-776 354-21	10 - 3
95-775 658-15	6 - 3	95-775 763-04/240	15 - 12	95-776 063-04	16 - 1	95-776 358-05	11 - 5
95-775 664-71/893	15 - 2	95-775 763-04/260	15 - 12	95-776 076-11	5 - 2	95-776 414-71/951	8 - 5
95-775 665-75/893	15 - 2	95-775 764-71/895	5 - 1	95-776 077-05	4 - 1	95-776 418-05	16 - 3
95-775 666-15	15 - 2	95-775 770-05	10 - 1	95-776 078-05	4 - 1	95-776 422-90	15 - 25,15 - 26
95-775 674-71/893	15 - 4	95-775 776-05	11 - 3	95-776 081-71/895	11 - 1	95-776 429-05	15 - 22
95-775 683-15	15 - 6	95-775 777-75/895	11 - 2	95-776 082-05	11 - 5	95-776 440-05	11 - 4
95-775 687-05	15 - 6	95-775 791-15	5 - 2	95-776 111-05	13 - 1	95-776 442-01	15 - 14
95-775 688-25	11 - 1	95-775 792-11	5 - 2	95-776 128-15	15 - 13,15 - 22	95-776 450-05	15 - 23
95-775 695-71/895	5 - 1	95-775 800-91	3 - 4	95-776 136-05	10 - 16	95-776 453-91	5 - 2
95-775 696-75/895	11 - 1	95-775 823-71/895	3 - 7	95-776 137-15	10 - 16	95-776 472-11	15 - 13
95-775 699-75/895	11 - 3	95-775 851-75/893	15 - 5	95-776 149-11	8 - 5	95-776 473-11	15 - 13
95-775 701-75/893	6 - 6, 6 - 7	95-775 880-05	15 - 3	95-776 187-91	10 - 16	95-776 475-11	15 - 17, 15 - 18
95-775 708-91	15 - 28	95-775 882-15	5 - 2	95-776 188-01	13 - 1	95-776 476-11	15 - 17, 15 - 18
95-775 710-91	15 - 28	95-775 884-05	6 - 2	95-776 189-15	13 - 1	95-776 516-05	15 - 25,15 - 26
95-775 715-90	15 - 6	95-775 885-15	6 - 2	95-776 190-05	7 - 2	95-776 519-90	15 - 14
95-775 718-75/895	11 - 4	95-775 886-15	6 - 2	95-776 196-01	13 - 1	95-776 535-70/895	15 - 28

No.	Seite Page Pages Página	No.	Seite Page Pages Página	No.	Seite Page Pages Página	No.	Seite Page Pages Página
95-776 537-05	15 - 28	95-778 132-25	3 - 4	95-778 423-15	8 - 6	95-850 737-05	15 - 23,15 -24
95-776 540-05	15 - 28	95-778 133-91	3 - 4	95-778 424-15	8 - 6	95-851 045-15	15 - 15
95-776 559-15	10 - 15	95-778 162-15	13 - 1	95-778 428-05	16 - 2	95-851 045-91	15 - 15
95-776 560-15	10 - 15	95-778 163-15	3 - 4	95-778 429-05	16 - 2	95-851 084-15	15 - 21
95-776 561-15	10 - 15	95-778 169-05	15 - 9	95-778 430-91	16 - 3	95-851 313-91	15 - 15
95-776 562-05	15 - 28	95-778 170-05	15 - 9	95-778 445-05	16 - 2	95-851 496-15	15 - 15
95-776 563-05	15 - 28	95-778 171-05	15 - 9	95-778 446-05	16 - 1	95-852 436-15	15 - 21
95-776 564-05	15 - 28	95-778 173-05	15 - 9	95-778 447-05	16 - 1	95-853 178-91	15 - 15
95-776 566-90	15 - 19	95-778 175-91	3 - 4	95-778 448-75/895	16 - 6	95-853 179-15	15 - 15
95-776 629-15	15 - 31	95-778 179-91	3 - 3	95-778 449-15	16 - 6	95-853 238-15	15 - 15
95-776 630-15	15 - 31	95-778 182-91	3 - 10	95-778 450-75/893	16 - 5	95-853 238-91	15 - 15
95-776 631-71/895	15 - 31	95-778 191-05	16 - 3	95-778 452-71/893	16 - 7	99-115 425-91	15 - 19
95-776 633-90	15 - 28	95-778 192-05	16 - 3	95-778 455-05	16 - 1	99-115 453-91	6 - 6, 6 - 7
95-776 695-05	15 - 17,15 - 18	95-778 215-75/895	8 - 7	95-778 467-15	7 - 1	99-115 505-91	3 - 11, 9 - 2, 9 - 4, 16 - 8
95-776 701-15	16 - 4	95-778 220-05	15 - 31	95-778 470-71/893	15 - 10,16 - 2	99-133 127-91	8 - 4
95-776 722-15	15 - 17,15 - 18	95-778 222-05	15 - 31	95-778 475-05	15 - 10	99-133 753-91	15 - 27
95-776 723-15	15 - 17,15 - 18	95-778 223-15	15 - 31	95-778 476-15	7 - 1	99-133 920-91	3 - 16
95-776 754-05	15 - 17,15 - 18	95-778 224-05	15 - 31	95-778 480-01	16 - 1	99-133 962-91	7 - 1
95-776 755-11	15 - 17,15 - 18	95-778 236-05	16 - 3	95-778 481-91	15 - 10	99-134 206-05	15 -19,15 -25, 15 - 26
95-776 761-91	15 - 23,15 - 24	95-778 237-05	16 - 3	95-778 548-91	3 - 13	99-134 207-05	3 - 4
95-776 765-05	15 - 23,15 - 24	95-778 249-05	16 - 3	95-778 558-91	15 - 29	99-134 255-91	15 - 19,15 -25, 15 - 26
95-776 766-05	15 - 23,15 - 24	95-778 282-05	3 - 3	95-778 559-15	15 - 29	99-134 256-91	15 - 17,15 -18, 15 - 23,15 -24, 15 - 27
95-776 767-05	15 - 23,15 - 24	95-778 296-15	11 - 5	95-778 560-91	15 - 29	99-134 421-91	15 - 17,15 - 18
95-776 768-05	15 - 24	95-778 364-15	10 - 15	95-778 562-05	15 - 29	99-134 586-91	10 - 15
95-776 769-05	15 - 23,15 - 24	95-778 374-91	3 - 4	95-778 563-15	15 - 29	99-134 594-71/893	5 - 1, 10 - 3
95-776 770-05	15 - 23,15 - 24	95-778 386-75/895	11 - 5	95-778 564-15	15 - 29	99-134 815-91	5 - 1
95-778 009-05	15 - 20	95-778 387-05	11 - 5	95-778 566-15	15 - 29	99-134 833-91	15 - 29
95-778 010-91	15 - 20	95-778 412-05	10 - 2	95-778 768-05	15 - 23	99-134 850-91	7 - 1, 15 - 30
95-778 089-05	3 - 2	95-778 413-05	3 - 2	95-850 315-15	15 - 20	99-134 851-91	3 - 11
95-778 125-75/895	15 - 8	95-778 414-05	16 - 3	95-850 316-15	15 - 20	99-134 935-91	5 - 1, 15 - 1, 15 - 2
95-778 128-91	3 - 3	95-778 415-15	16 - 2	95-850 560-15	15 - 15	99-135 002-95	3 - 9, 15 - 12, 15 - 23,15 - 24
95-778 130-71/698	3 - 4	95-778 416-15	16 - 2	95-850 633-05	15 - 24	99-135 184-91	15 - 23,15 - 24
95-778 131-25	3 - 4	95-778 417-05	16 - 2	95-850 658-05	15 - 22		

No.	Seite Page Pages Página	No.	Seite Page Pages Página	No.	Seite Page Pages Página	No.	Seite Page Pages Página
99-135 298-91	15 - 17,15 - 18, 15 - 29	99-136 873-91	15 - 16,15 - 20				
99-135 353-91	9 - 3, 16 - 8	99-136 590-01	8 - 2				
99-135 431-91	9 - 6	99-137 005-15	15 - 14				
99-135 490-91	3 - 4, 3 - 9, 3 - 19, 15 - 12	99-137 076-05	3 - 18				
99-135 496-95	8 - 4, 9 - 3, 9 - 4, 15 - 19, 16 - 8	99-137 077-91	3 - 11				
99-135 549-91	10 - 16	99-137 079-05	3 - 1				
99-135 556-91	9 - 5	99-137 085-91	6 - 3				
99-135 601-91	3 - 21	99-137 086-91	6 - 6, 6 - 7				
99-135 613-91	15 - 12	99-137 087-05	15 - 1, 15 - 2				
99-135 617-95	8 - 4, 9 - 5, 10 - 16	99-137 151-45	3 - 6				
99-135 663-91	3 - 17	99-137 169-91	15 - 12				
99-135 664-91	3 - 17	99-137 170-91	9 - 6				
99-135 665-91	3 - 17	99-137 171-91	13 - 1				
99-135 776-91	3 - 17	99-137 172-91	8 - 7				
99-135 809-91	3 - 21	99-137 174-91	10 - 15				
99-135 818-05	9 - 3, 15 - 12, 16 - 8	99-137 181-91	3 - 11				
99-135 819-05	9 - 3, 15 - 12, 16 - 8	99-137 182-91	7 - 1				
99-135 835-05	15 - 19,15 - 25, 15 - 26	99-137 185-95	3 - 11				
99-135 911-91	15 - 12,15 - 27	99-137 200-05	10 - 15				
99-136 009-75	11 - 5	99-137 206-91	4 - 1, 15 - 9, 16 - 1				
99-136 071-95	15 - 27	99-137 229-91	15 - 27				
99-136 072-95	9 - 5	99-137 269-91	9 - 1, 15 - 25, 15 - 26, 16 - 8				
99-136 161-91	15 - 29	99-137 270-91	9 - 1, 16 - 8				
99-136 205-91	8 - 4	99-137 271-91	9 - 3, 16 - 8				
99-136 220-91	10 - 16, 15 - 24	99-137 327-91	7 - 1				
99-136 235-91	3 - 19	99-137 446-05	3 - 4				
99-136 345-91	5 - 1	99-137 469-91	16 - 3				
99-136 396-91	3 - 16	99-137 618-05	11 - 5				
99-136 409-91	3 - 16						
99-136 585-95	4 - 1, 11 - 2, 11 - 5, 15 - 9, 16 - 1						
99-136 601-91	3 - 9						
99-136 846-91	15 - 6						



Europäische Union
Wachstum durch Innovation – EFRE



PFAFF Industriesysteme und Maschinen AG

Hans-Geiger-Str. 12 - IG Nord
D-67661 Kaiserslautern

Telefon: +49-6301 3205 - 0
Telefax: +49-6301 3205 - 1386
E-mail: info@pfaff-industrial.com